



**NIO** eL7

# User Manual

## EL7 Disclaimer

Thank you for choosing NIO's EL7 model (hereinafter referred to as "EL7"). EL7 is a smart electric vehicle. During your green journey with EL7, you will get a seamless and considerate user experience.

Before starting your journey with EL7, it is recommended that you read the User Manual from the center display to get all the information you need to use the vehicle.

- The contents of this manual shall not be reproduced or modified in whole or in part without legal and valid authorization.
- To avoid failure of the vehicle's function or personal injury, vehicle parts shall not be modified, adjusted or dismantled without legal and valid authorization.
- The labels, logos and pictures used in this manual are for illustration purposes only, and the content is for reference only.

The description and illustration in this manual are for reference only. The actual equipment, configuration, and features of your vehicle may differ from those described and illustrated in this manual, but will be upgraded with the software version update of your vehicle. For the avoidance of doubt, NIO reserves the right to decide whether and when to provide the vehicle's equipment, configuration, features, and related software upgrades for safety, compliance with laws and regulations, and other considerations.

Please strictly follow the warning information in this manual to use your vehicle more safely. Please also keep updated with any other warnings issued by NIO. Please make sure that you have carefully read the latest version of this manual and are familiar with the features of EL7 prior to use. **NIO shall not bear any liability for any personal injury to you/others or damage to your vehicle/property caused by failure to properly operate EL7 as instructed.**

- **Warning:** This content is closely related to personal safety and must be complied. Failure to comply may lead to personal injury or serious accident.
- **Caution:** This content gives you tips on how to avoid possible vehicle damage or property damage.
- **Note:** This content gives you suggestions for better use of your vehicle.

If you have any questions about this manual, please contact us by phone, or log on to the NIO official website to obtain the latest version of the EL7 User Manual.



If you need assistance in an emergency, please contact us by phone .

# Contents

## 1 Locks

- 1 Car Locating (Find My Car)
- 2 Unlocking/Locking with Smart Key Fob
- 5 Replacing the Smart Key Fob Battery
- 7 Keyless Unlocking/Locking
- 9 Unlocking, Starting and Locking with NIO App
- 10 Unlocking/Locking via Bluetooth
- 12 Unlocking/Locking via NFC
- 14 Unlocking/Locking with the Central Lock
- 15 Emergency Unlocking/Locking
- 18 Walk Up Unlock
- 19 Auto Unlock in PARK
- 20 Walk-Away Lock
- 21 Drive-Away Locking
- 22 Anti-Theft Alarm System

## 2 Doors < Windows

- 23 Door Handles
- 25 Easy Entry
- 28 Tailgate
- 32 Window Control
- 34 Sunroof and Sunshade

## 3 Charging

- 35 Charging Instructions
- 37 Charging
- 41 Battery Level and Charging Display
- 43 Battery Warmup

## 4 Lights

- 47 High Beams and Low Beams
- 48 Turn Signals
- 49 Fog Lights
- 50 Welcome Lighting
- 51 Exterior Door Handle Courtesy Lights
- 52 Reading Lights
- 54 Puddle Lights
- 55 Smart Ambient Lights
- 56 Illuminated Door Sill Inlays
- 57 Vanity Mirror Lights
- 58 Follow Me Home

- 59 Minimal Lighting
- 60 Search Lighting
- 61 Night Lighting
- 62 Trunk Lighting

## 5 Account and Memory

- 63 Linking Key Fob to Account
- 64 Switching Accounts
- 65 Authorized Unlocking
- 67 Guest Mode
- 68 Service Authorization
- 69 Driver Seat Memory
- 70 Steering Wheel Memory
- 71 Side Mirror Memory
- 73 Passenger Seat Memory

## 6 Seats

- 74 Driver Seat Adjustment
- 78 Passenger Seat Adjustment
- 83 Rear Seat Adjustment
- 86 Rear Premium
- 87 Seat Headrest Adjustment
- 89 Seat Massage
- 90 Seat Heating
- 91 Seat Ventilation
- 92 Seat Relaxation

## 7 Storage

- 93 Front Storage Space
- 95 Rear Storage Space
- 98 Center Storage Box
- 100 Trunk
- 102 Easy Loading

## 8 Steering Wheel

- 103 Steering Wheel Adjustment
- 105 Right Buttons on the Steering Wheel
- 107 Left Buttons on the Steering Wheel
- 108 Steering Wheel Heating
- 109 Steering Wheel Dual-Button Restart

## 9 In-Vehicle Power Supply

- 111 USB Ports
- 112 12V Power Outlets

## 10 Wipers and Side Mirrors

- 113 Front and Rear Windshield Wipers
- 117 Side Mirror Adjustment
- 118 Side Mirror Folding
- 119 Side Mirror Heating
- 120 Rearview Mirror and Side Mirror Auto-Dimming

## 11 Climate Control

- 121 Front Climate Control
- 127 Rear Climate Control
- 130 Air Purification

## 12 Customized Entertainment

- 131 Music
- 132 Navigation
- 133 Photos and Videos
- 134 Phone
- 135 Connecting to Mobile Devices
- 137 Wireless Charging
- 139 NOMI
- 143 Comfort Features
- 144 Intelligent Fragrance System
- 146 Tide
- 149 Quick Access

## 13 Instrument Cluster and Center Display

- 150 Instrument Cluster Indicators
- 153 Controls on Center Display
- 155 Event Data Recorder (EDR)
- 157 System Update
- 158 Resetting All Settings

## 14 Driving Experience

- 159 Basic Operation
- 162 Drive Modes
- 164 Scenario Assist
- 166 Feature Settings
- 169 Digital Video Recorder (DVR)
- 172 Pedestrian Warning System
- 173 Parking Camera and Parking Assist

## 15 Vehicle Safety

- 178 Seat Belts
- 182 Airbags
- 188 Child Protection Locks
- 189 Child Seat
- 197 Multi Collision Braking (MCB)

- 198 Pet Mode
- 200 Powered On Walk-away Mode
- 202 Camping Mode
- 204 Child Presence Detection (CPD)

## 16 Safety Assist Features

- 205 Front Collision Warning (FCW)
- 210 Autonomous Emergency Brake (AEB)
- 216 Lane Keeping Assist (LKA)
- 224 Emergency Active Stop (EAS)
- 229 Emergency Lane Keeping (ELK)
- 237 Advanced Driver Monitoring System (ADMS)
- 241 Blind Spot Detection (BSD) and Lane Change Assist (LCA)
- 245 Door Open Warning (DOW)
- 248 Front Cross Traffic Alert
- 251 Rear Cross Traffic Alert with Braking (RCTA-B)

## 17 Driver Assist Features

- 255 Auto Lane Change (ALC)
- 263 Lane Centering Control (LCC)
- 280 Adaptive Cruise Control (ACC)
- 296 Semi-Automatic Parking Assist
- 308 Power Station Automatic Parking (PSAP)
- 313 Side Distance Indication System (SDIS)

## 18 Vehicle Maintenance

- 316 Vehicle Health Status
- 317 Maintenance Instructions
- 318 Regular Maintenance
- 321 Front Wiper Blade Replacement
- 322 Rear Wiper Blade Replacement
- 323 Windshield Washer Fluid Refill
- 324 Coolant Refill
- 326 Brake Fluid Refill
- 328 Tire Inspection and Maintenance
- 331 Brake Pad and Disc Inspection and Maintenance
- 332 Air Filter Inspection and Maintenance
- 333 12V Battery Maintenance
- 334 High Voltage Battery Maintenance and Recycling
- 337 Underhood Fuse Box
- 341 Instrument Panel Fuse Box
- 348 Trunk Fuse Box
- 352 Pre-Fuse Box

353 Exterior Cleaning and Maintenance  
357 Interior Cleaning and Maintenance  
359 Application of Antibacterial Product

## 19 General Vehicle Info

361 Vehicle Info  
362 Instrument Cluster and Controls  
363 Warning Sign Information  
365 Vehicle Identification Number (VIN)  
367 Driving Motor Identification Labels  
368 Recommended Fluids and Capacities  
369 Powertrain Information

## 20 Specifications and Parameters

373 Vehicle Dimensions  
374 Mass Parameters  
375 Wheel and Tire Specifications  
377 Motor Parameters  
378 Braking and Suspension Specifications  
379 High Voltage Battery Parameters

## 21 Tire Information

380 Tire Inflation  
383 Tire Pressure Monitoring System (TPMS)  
384 Tire Chains  
385 AutoSock  
386 Winter Tires  
387 Tire Repair  
391 Tire Replacement

## 22 Emergency Measures

394 Placing a Warning Triangle  
396 Contacting NIO  
401 Jump Starting  
403 Emergency Unlocking from the Outside  
405 Emergency Unlocking from the Inside  
406 Emergency Tailgate Opening  
407 First Aid Kit

## 23 Breakdown Services

408 Protective Equipment for Rescue Operations  
409 Cutting Off the High Voltage Circuit  
411 Towing the Vehicle after an Accident

413 Rescuing the Vehicle in Water  
414 Rescuing the Vehicle on Fire  
415 Rescuing the Vehicle with Battery Leakage  
416 Vehicle Cutting

## Car Locating (Find My Car)

### ***Car Locating at a Distance***

You or an authorized user can conveniently check the vehicle's location on the NIO app. When the vehicle is connected to the Internet, you can view its location at the top of **My Car** on the NIO app. Tap this information to view the vehicle's location on the map.

### ***Car Locating at Close Proximity***

When the vehicle is not being driven and the authenticated key fob is within 70 meters to the vehicle, press the Lock button on the smart key fob twice within three seconds. The vehicle's horn will honk and the turn signals will flash to indicate the vehicle's exact location. Press the button again after 5 seconds to clear the location prompt. Otherwise, the location prompt will turn off automatically after 10 seconds.



When the vehicle is connected to your phone via Bluetooth or the vehicle is connected to the Internet, you can also locate it by tapping **My Car > Find My Car** on the NIO app. The vehicle's horn will honk and the turn signals will flash to indicate its location. Tap **Find My Car** again to clear the location prompt.

## Unlocking/Locking with Smart Key Fob

Before entering the vehicle, you can unlock it with the smart key fob. The maximum effective range of the smart key fob is 30-70 meters away from the vehicle and may vary with the status of the smart key fob.

The smart key fob has the following buttons:



### 1. Unlock

When the vehicle is in PARK, press the button to unlock the vehicle. If successful, the turn signals will flash three times, and the exterior door handles will extend automatically.

When all four doors are unlocked with the smart key fob, the tailgate can be opened from the outside without a key.

To open all windows, press and hold the lock button. The windows will stop moving after you release the button.

You can set the unlocking mode for your smart key fob on the center display. Enter Settings from the bottom of the center display, and tap **Doors & Windows > Vehicle Unlock Mode**. Choose "All" to unlock all doors at once by pressing the smart key fob. Choose "Driver" to unlock the driver's door first by pressing the smart key fob once, and then the remaining three doors by pressing the smart key fob again.

### 2. Lock

When the vehicle is in PARK and all doors (including the hood and the tailgate) are closed, short press the button to lock the vehicle. If successful, the turn signals will flash once, and the vehicle's horn will honk once.

Meanwhile, the exterior door handles will retract, and the side mirrors will fold automatically (to turn on the side mirror auto-fold, enter Settings from the bottom of the center display, and tap **Driving > Side Mirrors > Auto Fold On Lock**).

After locking, the tailgate can only be opened from the outside using the smart key fob.

To enable/disable the lock confirmation sound, enter Settings from the control bar at the bottom of the center display, and tap **Sound > Ringer & Alerts > Lock Sound**.

To close all windows, press and hold the lock button. The windows will stop moving after you release the button.

When the vehicle is not being driven and the authenticated key fob is within 70 meters of the vehicle, press the button twice in a row within three seconds. The vehicle's horn will honk, and the turn signals will flash to indicate the vehicle's location. Press the button again after 5 seconds to clear the location prompt. Otherwise, the location prompt will turn off automatically after 10 seconds.

When all the doors are closed, you can press the lock button on the smart key fob outside the vehicle to lock the vehicle. The turn signals will flash once, and the horn will honk once to indicate that the vehicle is locked. If there are doors left open, you are not able to lock the vehicle by pressing the lock button. You will receive a message reminding you that your vehicle was not successfully locked.

### 3. Tailgate

When the tailgate is closed, press and hold the button to open the tailgate. After the tailgate is opened, press and hold the button again to close the tailgate.

### Warning

When leaving a person or a pet in the vehicle, you must ensure that you have your smart key fob with you. Failure to do so may result in injury or death.

### Caution

- The smart key fob is an electronic component. Protect it from any impact or disassembly, high temperatures, damage from liquids, or strong vibrations.
- Even though there are occupants in the vehicle, you can still lock the vehicle with the smart key fob. The occupants can get out of the vehicle when needed, but the anti-theft alarm system will be triggered.
- If a smart key fob or phone with the Bluetooth digital key is left in the vehicle, you can still lock the vehicle with smart key fob, and the NIO app will remind you of a key left in the vehicle.

- If an occupant accidentally takes the smart key fob or phone with the Bluetooth digital key out of the vehicle for more than 3 meters, the vehicle will remind you of a key out of the range.
- If any door or the liftgate is not opened within 30 seconds after the vehicle is unlocked, all of the doors and the liftgate will lock automatically.
- If the key fob is lost or damaged, please contact NIO immediately and take all of your keys to NIO for authentication, or apply for new key fobs.

### Caution

When the key fob battery is low, use the emergency key to lock the driver's door. All other doors will be locked at the same time.

### Note

After closing the driver's door and locking the vehicle, if you accidentally leave the smart key fob in the vehicle when closing another door, the anti-lockout feature will activate automatically. In this case, the vehicle will unlock automatically, the turn signals will flash three times, and the horn will honk three times.

When the vehicle is in PARK, you can enter Settings from the bottom of the center display, and tap **Doors & Windows > Auto Window Closing** to set auto window closing upon vehicle lock. When you lock the vehicle from the outside (with a smart key fob, NFC, NIO app, keyless locking, or Walk-Away Lock), all the windows will close automatically with anti-pinch protection engaged. When the windows are closing, if you press the lock button on the key fob or mobile app, the windows will stop closing.

### Caution

- When turning on Auto Window Close, please ensure the vehicle is locked.
- For occupants' safety, when a front seat is occupied, if the vehicle is locked, the windows will not close. Please do not leave occupants or pets in the locked vehicle.
- If the vehicle is locked while a window is rising, the window will stop rising. In this case, unlock the vehicle first, then lock the vehicle again, and the windows will close automatically.



## Replacing the Smart Key Fob Battery

The smart key fob uses a CR2477 coin cell battery. To replace the battery, please pinch the sides of the key fob firmly between fingers, and slide your fingernail or a thin plastic sheet from the bottom gap along the side slit of the key fob until the rear cover can be opened.

Dispose of used batteries according to instructions and local laws. Please see the NIO website for details.



Install the coin cell battery with the positive terminal facing down. After installing, align the battery's contacts, and then close the rear cover properly to ensure proper use of the key fob.

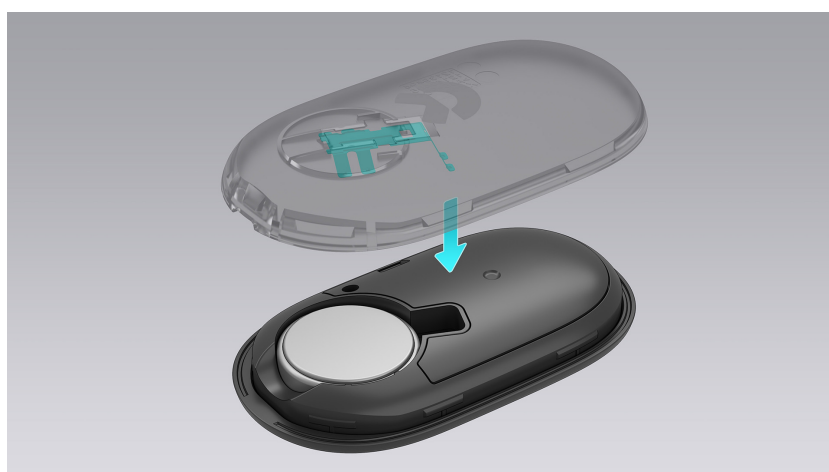

### Caution

When the key fob battery is low, its remote unlock feature may be affected. In this case, you can try to unlock the vehicle from a shorter distance. If it still doesn't work, please use other methods (e.g. the mobile app or emergency key) to unlock the vehicle.

**Caution**

Radio waves may affect the performance of the key fob. Keep other electronic devices (e.g. phones, laptops and tablets) at least 30 cm away from the key fob.

## Keyless Unlocking/Locking

When you carry an authenticated smart key fob or Bluetooth (in your pocket or bag), you can unlock or lock the vehicle simply by touching the rear end of any exterior door handle.

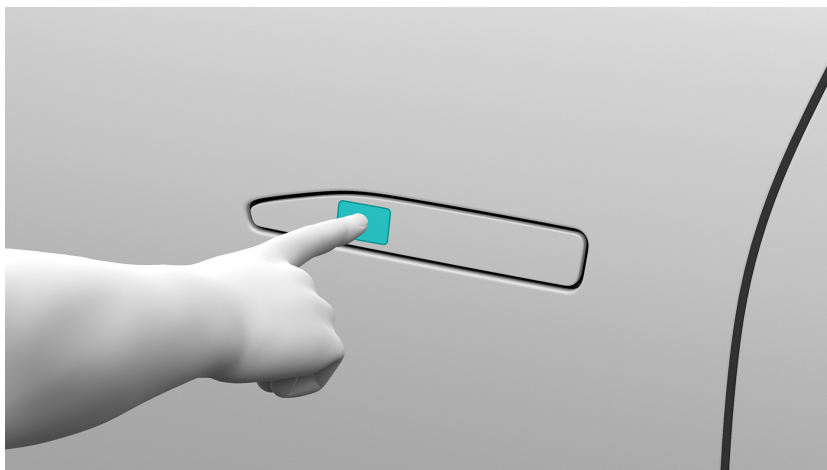

If the key fob is left in the vehicle or a door is open (including the hood or the tailgate), the vehicle cannot be locked by pressing the end of an exterior door handle. At this time, the horn honks to remind you to take the key fob with you or close the open door.

### Caution

To unlock/lock the vehicle without using a key, ensure that the vehicle is in PARK and that all doors, hood and liftgate are closed.

### Caution

When locking the vehicle without a key, avoid pressing too hard on the exterior door handle.

### Warning

Patients who are dependent on pacemakers should stay at least 22 centimeters away from the interior antennas, to avoid their cardiac pacemakers from being interfered by the keyless unlocking system's antenna.

Locations of the interior Bluetooth antennas are as follows:

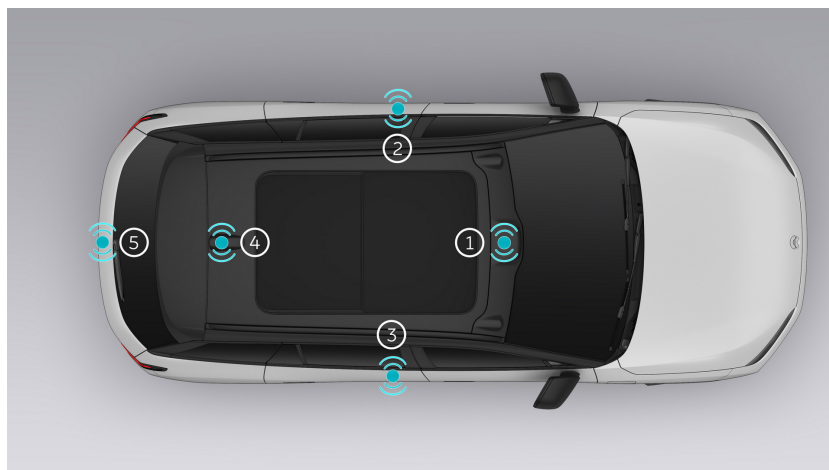

1. Under the rearview mirror cover
2. Under the rear left door
3. Under the rear right door
4. Behind the headliner
5. Above the rear bumper bracket

## Unlocking, Starting and Locking with NIO App

You can remotely unlock or lock the doors and start the vehicle when you are still away from the vehicle by tapping Door Locks in My Vehicle on the NIO app. Doing this allows you to lend your vehicle to someone else.

You can enable the following unlocking features:

- **Unlocking doors only**  
Only the doors are unlocked, with the door handles extending automatically. At this point, you can tap "Remote Start", and then sit in the driver's seat and press the brake pedal within 2 minutes to start the vehicle.
- **Unlocking and starting the vehicle**  
After the vehicle is unlocked with the door handles extending, you can start the vehicle remotely. Sit in the driver's seat and press the brake pedal within 2 minutes to start the vehicle.  
The vehicle will exit the remote start mode after the driver finishes driving and leaves the seat. You can proceed with remote vehicle start once again by tapping "Remote Start" in "My Vehicle".

### Note

If you do not press the brake pedal to start the vehicle within 2 minutes after Remote Unlocking and Starting is enabled, the vehicle will automatically exit the remote start mode. At this point, you can press the "Remote Start" button to start the vehicle.

To unlock/lock and start the vehicle on the NIO app, ensure that the following conditions are met:

1. The user must be the vehicle's owner or a user authorized by the owner.
2. The vehicle is in PARK with all doors closed.
3. The phone and vehicle are connected to the Internet.
4. Your phone's Unlocking and Starting via Bluetooth feature is disabled (otherwise Bluetooth will be preferred for unlocking and starting).

### Note

If you or an authorized user cannot unlock the vehicle using the NIO app, please contact NIO for assistance.

## Unlocking/Locking via Bluetooth

The Unlocking and Starting via Bluetooth feature enables you to easily and quickly unlock/lock the vehicle without a smart key fob.

First, open the NIO app. Tap **My Vehicle > Settings > Bluetooth Digital Key** to create a Unlocking and Starting via Bluetooth service. Then enable this service and Bluetooth on your phone, and keep your phone close to an unlocked vehicle to pair the vehicle with your phone and activate this service. After successful activation, the top of the My Vehicle page will show that your phone has been connected to the vehicle via Bluetooth digital key, and then you can use the Bluetooth digital key to replace the smart key fob for unlocking and locking your vehicle. Then your phone will be automatically connected to your vehicle when approaching. You can also go to the Key Management page to manage the Bluetooth digital key or delete it as needed.

If the vehicle is in PARK, when you approach it (about 30–70 meters at maximum, which may vary according to the status of Bluetooth connection) with your phone's Unlocking and Starting via Bluetooth enabled, you can perform the following operations:

- Tap the Unlock/Lock button on the My Vehicle page of the NIO app to unlock/lock the vehicle, with the door handles extending or retracting automatically.
- After unlocking your vehicle successfully with the Bluetooth digital key, you just need to get seated and close the driver's door and then press the brake pedal to start the vehicle.
- Carry your phone and touch the designated area on the door handle to unlock/lock the vehicle.
- After enabling the Walk-Up Unlocking feature on the center display, when you enter the specified range area around the vehicle with your phone, the vehicle will unlock automatically.
- After enabling the Walk-Away Lock feature on the center display, when you leave the vehicle for the specified distance with your phone, the vehicle will automatically lock.
- You can press the trunk switch or go to the My Vehicle page of the NIO app to open/close the truck.
- You can find your vehicle, adjust windows, your vehicle via the My Vehicle page of the NIO app.

**Caution**

- If you fail to lock or unlock the vehicle with the Bluetooth digital key due to a Bluetooth connection error, fix the error and try again.
- If the Bluetooth connection between your phone and the vehicle fails when you try to start the vehicle with the Bluetooth digital key, please reconnect via Bluetooth and try again.
- The Bluetooth digital key is only available for a paired phone. If you use a new phone, create a new Bluetooth digital key, and the Bluetooth digital key on the previous phone will be disabled automatically. To log in to the account, you need to reactivate the Bluetooth digital key.
- Both the vehicle owner and authorized users can create a Bluetooth digital key, but the number of Bluetooth digital keys that can be paired with the vehicle is limited.
- Even though there are occupants in the vehicle, you can still lock the vehicle with the Bluetooth digital key. The occupants can get out of the vehicle when needed, but the anti-theft alarm system will be triggered.
- If a smart key fob or phone with the Bluetooth digital key is left in the vehicle, you can still lock the vehicle with smart key fob, and the NIO app will remind you of a key left in the vehicle.
- If an occupant accidentally takes the smart key fob or phone with the Bluetooth digital key out of the vehicle for more than 3 meters, the vehicle will remind you of a key out of the range.

## Unlocking/Locking via NFC

You or an authorized user can unlock or lock the vehicle using an NFC-enabled phone or NFC card. After unlocked, the liftgate can be opened from the outside.

To unlock or lock the vehicle using your phone:

1. Tap **My Car > Vehicle Info > NFC Key** on the NIO app, install the "NIO NFC Key" app on your phone, and turn on the "NFC Key". An "NFC" icon will be displayed in the top left corner of "My Car".
2. Enable the NFC function on your phone and set the NIO app as the default payment application.
3. Keep the phone screen awake and place it close to the NFC detection zone on the driver-side B-pillar. Next, the app will display "Unlocking With NFC." After successfully unlocking, the door handles will extend automatically. After successfully locking, the door handles will retract automatically with a locking sound.



Place the NFC card close to the NFC detection zone on the driver-side B-pillar, and hold it for a while to unlock or lock the vehicle automatically. After successful unlocking, the door handles will extend automatically. After successful locking, the door handles will retract automatically with a locking sound.

### Caution

- The NFC's detection range is less than 10 millimeters. It is recommended to place your mobile phone or NFC card near the NFC detection area for a short period to unlock or lock the vehicle.



- After unlocking the vehicle via NFC, you can still lock it using other methods (e.g. your smart key fob or emergency key). We recommend carrying your smart key fob or phone with you.
- Please keep your NFC card safe. Protect it from impact, bending, high temperatures, strong vibration, and damage from liquids.
- You cannot use the NFC feature during vehicle updates. Please carry the smart key fob with you to unlock the vehicle.
- When unlocking or locking the vehicle via NFC, please log into the NIO app and redownload the NFC key if you are unable to obtain an authenticated NFC key. If an authenticated NFC key is not detected, please ensure that the vehicle matches the NFC account. Then reopen the NFC app and unlock the mobile phone screen to unlock or lock the vehicle again. If NFC still doesn't work, please contact NIO.

## Unlocking/Locking with the Central Lock

You can unlock or lock the vehicle by pressing the central lock button.



When the vehicle is unlocked and all doors are closed, you can lock the vehicle from the inside by pressing the central lock. After locking, a **Vehicle Locked** icon will appear on the center display and the button LED light will turn green.

When the vehicle is locked from the inside or only the driver door is unlocked, you can unlock the vehicle from the inside by pressing the central lock. After unlocking, a Vehicle Unlocked icon will appear on the center display, and the button LED light will turn off.

## Emergency Unlocking/Locking

### ***Unlocking/Locking from the Outside***

When you are unable to unlock or lock the vehicle from the outside with one of the aforementioned methods, you can use the emergency key to unlock or lock the driver door.

### **Caution**

Do not leave the emergency key in your vehicle. Please keep it safe in case of emergency.

To use the emergency key:

1. Push the front end of the exterior handle on the driver door.



2. Pull the door handle and insert the emergency key into the lock. Rotate the key counterclockwise to unlock the driver door.



3. To lock the driver door, rotate the key counterclockwise first for unlocking and then turn it clockwise.

### Caution

To lock the vehicle with the key fob after it has been unlocked with the emergency key, reset the lock cylinder by unlocking and then locking the driver's door to keep the vehicle safe.

When the 12V battery level is low, only the driver door will be locked by the emergency key. If you want to lock the other doors, you can toggle down at the keyhole and close the door to lock it. In this case, the door cannot be opened from the outside.

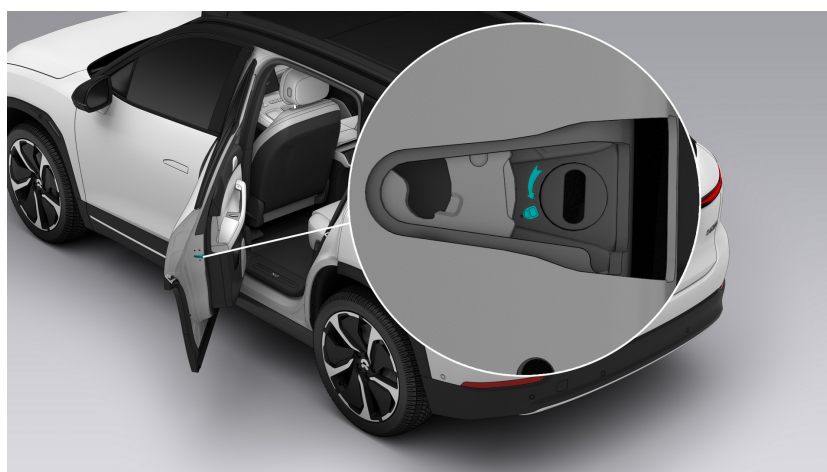

### ***Unlocking from the Inside***

When the whole vehicle is locked, if the door needs to be opened in an emergency (for example, when the electronic switch on the door handle fails or the vehicle

falls into the water), pull the mechanical switch on the interior door handle once to open the corresponding door.

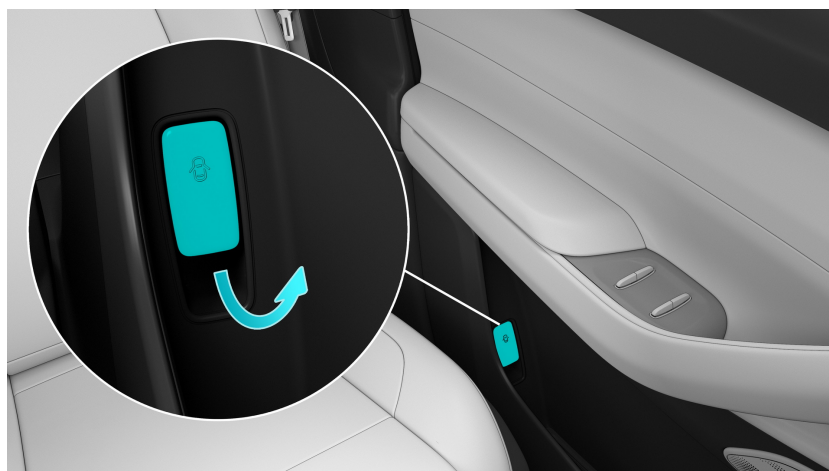

### Caution

- If the 12V battery is drained, you can only unlock the driver door using the emergency key. Other doors can be unlocked and opened from the inside by pulling the mechanical switch on the corresponding interior door handle.
- When Child Lock is on, the rear doors cannot be opened from the inside and can only be opened from the outside when the vehicle is unlocked.

## Walk Up Unlock

Walk Up Unlock works when you carry a valid smart key fob or a phone with the Unlocking and Starting via Bluetooth feature enabled. The vehicle will automatically unlock when you are within about 1.5 meters of the B pillar.

You can enter Settings from the bottom of the center display, and tap **Doors & Windows > Walk-Up Unlock** to enable this feature.

## Auto Unlock in PARK

The vehicle automatically unlocks in PARK.

If the vehicle is locked automatically while driving (at a speed over 8 km/h), the vehicle will unlock the doors automatically when you stop the vehicle by pressing the brake pedal and shifting into PARK. After unlocking, the tailgate can be opened from the outside without a key.

Enter Settings from the bottom of the center display, and tap **Doors & Windows > Auto Unlock in PARK** to set this feature.

- Choose **All** to allow all doors to unlock automatically in PARK. In this setting, the tailgate can be opened from the outside.
- Choose **Driver** to allow only the driver's door to unlock automatically in PARK.

## Walk-Away Lock

Walk Away Lock works when you carry a valid smart key fob or a mobile phone with the Unlocking and Starting via Bluetooth feature enabled. The vehicle will automatically lock when you walk 3-7 meters away from it. When the vehicle is locked by Walk-Away Lock, a lock sound will be provided, the turn signals will flash, and the side mirrors will fold automatically if Auto Fold On Lock is enabled.

You can enter Settings from the bottom of the center display and tap **Doors & Windows > Walk-Away Lock** to enable this feature. Please only use Walk-Away Lock in familiar and safe areas. After Walk-Away Lock is turned on, be sure to carry an authenticated smart key fob with you or enable the Unlocking and Starting via Bluetooth feature on your phone, and check that the vehicle is successfully locked as you walk away.

### Warning

- When Walk-Away Lock is turned on, ensure that no child or pet is left in the vehicle so as to avoid any accidents.
- When using Walk-Away Lock, please ensure the vehicle is locked via the lock sound or visual checks (headlights, side mirrors or the NIO app), so as to protect the property inside your vehicle.
- When there is another authenticated smart key fob in the vehicle or any other condition for locking is not met (such as a door, the hood, or the liftgate not being closed or turning Walk-Away Lock off on the center display), Walk-Away Lock will fail.
- Please do not place your smart key fob close to a mobile phone, Bluetooth headset, or other communication devices. Otherwise, the vehicle may be locked by mistake due to signal interference.
- Equipment with a strong magnetic field such as DC chargers or high voltage substations may interfere with the smart key fob's signal, which may lock the vehicle by mistake in certain cases. It is recommended to carry your smart key fob with you to avoid any inconvenience caused by the unintended locking of the vehicle.



## Drive-Away Locking

Your vehicle can automatically lock while driving.

When the vehicle is unlocked and all doors, the front hood, and the tailgate are closed, the vehicle automatically locks all doors when the driving speed exceeds 8 km/h.

### Note

Drive Away Locking will only be activated once the vehicle transitions from being stationary to moving.

## Anti-Theft Alarm System

After the vehicle is locked (including the front hood and tailgate) from the outside with the smart key fob, the NIO app, the NFC feature, or the emergency key, the anti-theft alarm system is activated automatically.

When someone tries to open the door without carrying an authenticated smart key fob (or carrying one without a valid authorization), the anti-theft alarm will be triggered. At this time, the turn signals will flash and the horn will honk. You can unlock the vehicle from the outside with the smart key fob, the NIO app, or the NFC key to deactivate the anti-theft alarm.

### Caution

If the key fob's battery is low and you need to unlock the vehicle with the emergency key, please place the key fob level on the front cup holder next to the center console within 15 seconds and ensure the button on the side of the key fob is facing the rear of the vehicle. Next, sit in the driver's seat and close the driver's side door or press the brake pedal. Otherwise, the anti-theft alarm will be activated.



## Door Handles

When the vehicle is unlocked, the exterior door handles will automatically extend. Touch the inside of a door handle gently with your hand. The door will slightly pop open, so that you can easily open the door. When closing the door, gently close it to the half-closed position, and the door will be automatically sucked to the closed position, resulting in a easy and pleasant experience.

You can enter Settings from the bottom of the center display, and tap **Doors & Windows > Door Handle Sensing Unlock** to enable or disable this feature.

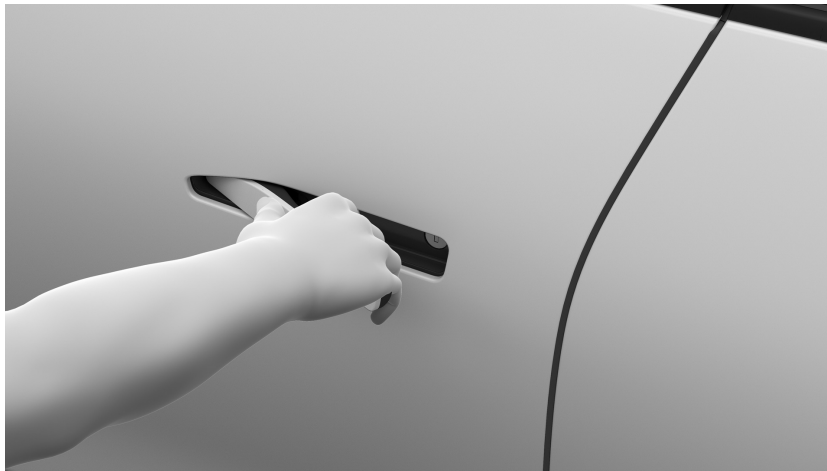

The exterior door handle will retract automatically when the vehicle is locked or is driving over 8 km/h.

### Warning

When the door automatically closes or the exterior door handles automatically retract, please ensure that occupants (especially children) keep their hands away from the door handles. Failure to do so may result in personal injury.

### Note

If the door handle does not extend because you are wearing insulated gloves, you can pull it slightly to open the door.

### Caution

If the exterior door handles cannot extend automatically, push the front end of the exterior door handle to deploy the corresponding handle.



When you are inside the vehicle, you can open a door can by pressing the corresponding electronic switch on the interior door handle. Press once if the vehicle is unlocked, and twice if the vehicle is locked. The corresponding door will pop open.

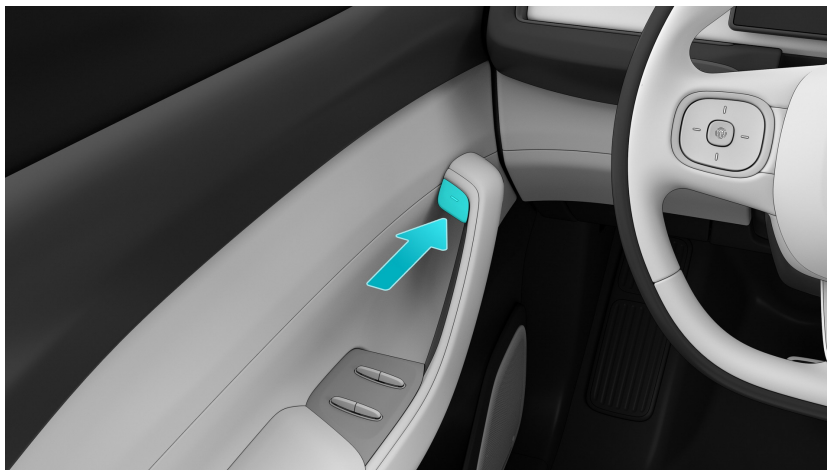

### Caution

- When the vehicle speed is higher than 3 km/h, the electronic switches on the interior door handles will be automatically disabled to ensure driving safety.

## Easy Entry

Easy Entry offers the driver and passengers multiple options and settings to make entering and exiting the vehicle more convenient.

### ***Driver Easy Entry***

After initializing the driver seat on the center display, you can set the most convenient exit position for you to get out of the vehicle. With the vehicle stopped and in PARK, the driver seat will move to the preset exit position (including the cushion position and backrest inclination) when you open the driver door, and the steering wheel will move to the uppermost position. This will provide you with a larger space to get in and out of the vehicle conveniently.



You can enter Settings from the bottom of the center display, and tap **Position Adjustment > Driver Seat > Driver Easy Entry** to enable or disable this feature. You or an authorized user can personalize the exit position for the corresponding account. After manually adjusting the driver seat to your desired exit position, tap **Position Adjustment > Driver Seat > Position Memory** and choose **Exit Position** to save the current settings. Every time you open the driver door or unfasten the seat belt (which can be selected from the center display) to get out of the vehicle, the driver seat will move to the corresponding exit position.

### **Caution**

When setting the exit position, do not move the seat to the rearmost position or recline the backrest to the lowest position. Doing so may adversely affect the rear passengers. You can set the recommended optimal exit position on the center display.

**Note**

After turning on Driver Seat Easy Entry, when you sit in the driver's seat and close the door (or press the brake pedal), the driver's seat, steering wheel, side mirrors and HUD height will automatically adjust to the settings saved in the system.

***Front Passenger Easy Entry***

If a passenger opens the front passenger door when the vehicle is stopped and in PARK, the front passenger seat will move to the preset exit position (the position of the cushion and inclination of the backrest will move to the rear, and the leg support will automatically move to its lowest position) to make entering and exiting the vehicle more convenient.



You can enter Settings from the bottom of the center display, and tap **Position Adjustment > Front Passenger Seat > Front Passenger Easy Entry** to enable or disable this feature. Front Passenger Easy Entry has two setting options:

- **Exit:** When the passenger unfastens the seat belt and opens the passenger door (which can be selected from the center display), the seat will move to the default position; when the passenger gets into the vehicle and closes the passenger door, the seat will remain unchanged from the default exit position.
- **Exit + Entry:** When the passenger unfastens the seat belt or opens the passenger door, the seat will move to the default position; when the passenger gets into the vehicle and closes the passenger door, the seat will automatically move to the default position saved in the corresponding account (which can be edited from the center display).

**Caution**

When using Front Passenger Easy Entry, it is recommended that you set the default position appropriately, and pay attention to the surrounding environment and the safety of any passengers in the second row.

***Ride Height Easy Entry***

When the vehicle is locked, the suspension automatically adjusts to the lowest setting for more convenient loading/unloading of cargo and passengers. When the vehicle is being driven, the suspension automatically raises to the height corresponding to the current drive mode.

Go to Settings from the leftmost side of the control bar at the bottom of the center display, and tap **Driving > Ride Height Easy Entry** to enable or disable the feature.

**Warning**

Before turning on Ride Height Easy Entry, ensure that the area underneath the vehicle is clear of people and any objects, and is on a flat road. Failure to do so may result in injury to people or damage to the vehicle.

## Tailgate

### *Opening the Liftgate by Pressing*



When you are carrying a smart key fob, you can open the liftgate by gently pressing the button on the liftgate handle.

While the liftgate is opening, press and hold the button to automatically save the current liftgate height.

### **Caution**

Before opening the liftgate, ensure that it is clear of objects such as snow and ice. Otherwise, the liftgate may suddenly close on its own.

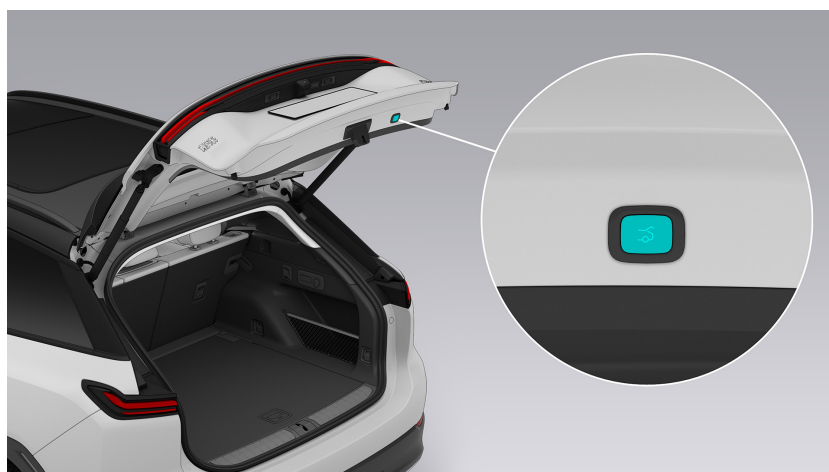

You can close the liftgate simply by pressing a button.

Press the button on the tailgate to automatically close and lock it.



### ***Opening/Closing the Liftgate via the Center Display***

Enter Quick Access from the center display by swiping right from the left edge and tapping **Tailgate** to open the tailgate.

Open tailgate: Press and hold **Open (Tap and Hold)**, and the tailgate will open automatically.

Close tailgate: Press and hold **Close (Tap and Hold)**, and the tailgate will close automatically.

When the tailgate is closing or opening, tap the tailgate Open or Close button to stop the tailgate.

### ***Opening/Closing the Liftgate with Smart Key Fob***



Open tailgate: Press and hold the Tailgate button on the smart key fob, and the tailgate will open automatically.

Close tailgate: Press and hold the Tailgate button on the smart key fob until the tailgate closes.

### **Caution**

This feature is unavailable when the smart key fob battery is low. Please replace the battery as soon as possible.

### ***Opening/Closing the Liftgate via the NIO App***

When the vehicle is in PARK and the doors are closed, you can tap **My Car > Tailgate** on the NIO app to open the tailgate. You will be notified if the tailgate is opened successfully. Tap the highlighted **Liftgate** button again to close the liftgate. If the liftgate is obstructed while closing, you will be notified that the liftgate has not closed successfully.

**Caution**

This operation is only available when the vehicle is connected to the Internet.

***Opening/Closing the Liftgate by Kicking***

When your hands are occupied, or it is inconvenient to use a key fob, the kick-activated liftgate can assist you.



To open the trunk lid with a kicking motion, quickly move your foot back and forth (at least 10 cm) one time under the center of the rear bumper, or kick horizontally at least 10 cm below the rear bumper.

You must carry a Bluetooth digital key or a smart key fob to use this feature.

**Note**

When kicking horizontally, move in a single direction instead of moving back and forth. Do not keep your foot under the bumper. Otherwise, the trunk lid will not open. Do not touch the trunk lid before it stops moving.

- When kicking horizontally, move in a single direction instead of moving back and forth.
- Do not keep your foot under the bumper. Otherwise, the trunk lid will not open.
- Do not touch the trunk lid before it stops moving.

The feature may be temporarily disabled for reasons including but not limited to the following:

- The liftgate is frequently opened or closed
- The foot is not taken back in time
- The kicking motion is not in the effective detection range

If the liftgate is unresponsive, you can try again after several seconds or use another approach to open or close the liftgate.

### **Caution**

- Ensure that the vehicle is stationary.
- Ensure that the range of the kicking motion is roughly in the middle of the rear bumper.

### **Warning**

- Do not drive the vehicle when the liftgate is open.
- To reduce the risk of being pinched, ensure that no one is near the liftgate operating area when opening or closing the liftgate.

### ***Opening/Closing the Liftgate Manually***

In case of an electrical failure, if the liftgate is not properly closed, it needs to be manually operated slowly and smoothly.

### **Warning**

Avoid opening and closing the liftgate vigorously and quickly, as this may result in component damage.

### ***Tailgate Anti-Pinch Protection***

The liftgate has an anti-pinch feature.

If an obstacle prevents the liftgate from opening or closing, the liftgate will stop its upward or downward motion, and the anti-pinch feature will be enabled.

- If the liftgate is obstructed when opening, it will stop and sound a long alert.
- If the liftgate is obstructed when closing, it will stop, sound a long alert, and move in the opposite direction for a short distance.

### **Warning**

To reduce the risk of being pinched, ensure that no one is near the liftgate operating area before opening or closing the liftgate.

## Window Control

The driver door has switches to control all four windows.

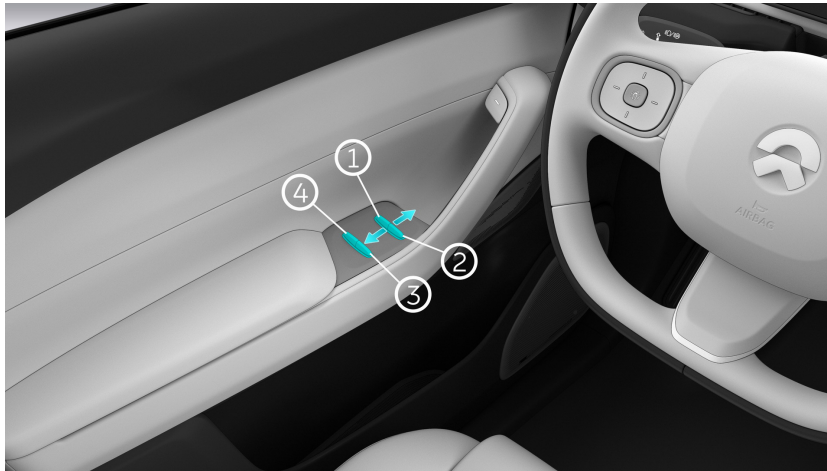

1. Driver window
2. Passenger side window
3. Rear window – right
4. Rear window – left

Each of the other three doors also has a switch on the armrest to control the corresponding window.

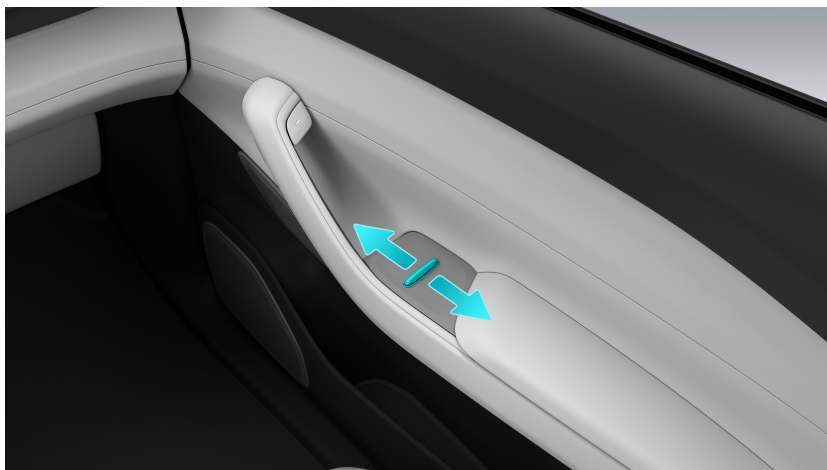

- To partially lower a window, toggle the corresponding switch forward; to fully lower a window, quickly toggle the switch forward all the way down and then release it (Quick Window Opening).
- To partially close a window, toggle the corresponding switch backward; to fully close a window, quickly toggle the switch backward all the way down and then release it (Quick Window Closing).

When the vehicle is in PARK and the driver seat is unoccupied, you can use the smart key fob to control the windows. With the doors, hood, and tailgate closed, press and hold the Unlock button on the smart key fob to fully open all windows; then press and hold the Lock button to fully close all windows; while the window is in motion, release the Unlock or Lock button to stop the windows at their current position.

All four windows feature anti-pinch protection. When an obstruction prevents the window from closing, the window will stop closing and move down slightly.

The window's anti-pinch detection area is as follows:



Under the following conditions, anti-pinch protection for the corresponding window will be temporarily disabled and Quick Window Closing will not be available (but will automatically be restored after 10 seconds):

1. The window is frozen, which stops the window from moving up.
2. Anti-pinch protection is activated three times within 15 seconds, which stops the window from moving up.

If a power window does not function and anti-pinch protection fails (e.g. due to restarting the low voltage battery after a power failure), you can initialize it as follows:

1. Toggle the corresponding switch backward until the window is fully closed.
2. Release the switch and the window will move down slightly. Toggle the switch backward again until the window is fully closed.
3. Press the switch to lower the window until it is fully open.

## Sunroof and Sunshade

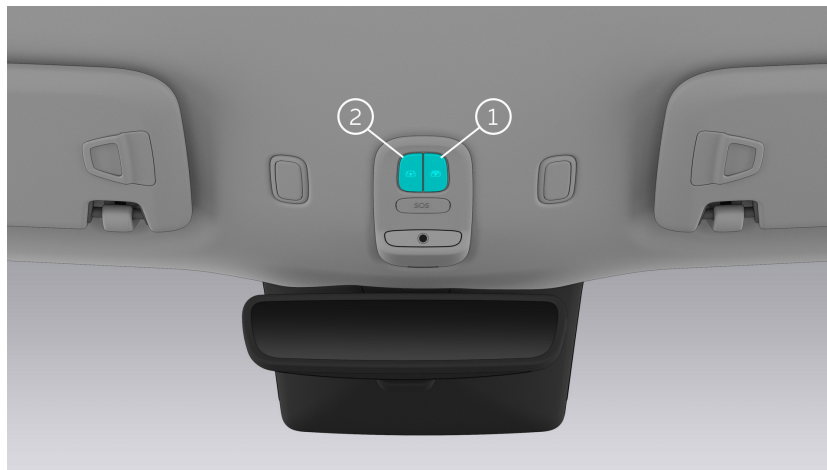

1. Sunshade switch  
Press and hold the rear part of the sunshade switch to fully open the sunshade; press the rear part of the sunshade switch to open the sunshade to the desired position.  
Press and hold the front part of the sunshade switch to fully close the sunshade; press the front part of the sunshade switch to close the sunshade to the desired position.
2. Sunroof button  
Press and hold the rear part of the sunroof button to open the sunroof fully and the sunshade halfway; press the rear part of the sunroof button to open the sunroof to the desired position.  
Press and hold the front part of the sunroof button to fully close the sunroof; press the front part of the sunroof button to close the sunroof to the desired position.

### Caution

The sunroof is not fully closed. The sunshade cannot be fully closed.

Despite the anti-pinch feature of the sunroof and sunshade, do not try it randomly to avoid injuries caused by malfunctions due to external factors.

## Charging Instructions

In order to maintain the vehicle in good condition, please promptly charge the vehicle when the battery level is low.

### Caution

The vehicle can only be charged in PARK. It cannot be charged in DRIVE or REVERSE, or during software updates.

The charge port is on the right side of the vehicle. The vehicle can be charged with DC or AC.

### Warning

- To avoid accidents, do not charge the vehicle near any flammable gases or liquids and make sure to charge the vehicle in a ventilated area.
- During charging, stay a safe distance from the charger to avoid any risks due to high voltage. Do not touch the charging connector's metal pins or the charge port. Doing so may result in injury.
- Minors are prohibited from using the charging equipment or approaching it during charging.
- Charging equipment which shows signs of damage, rust, moisture or foreign matter should not be used for charging the vehicle.
- Unauthorized modification or disassembly of the charging connector or equipment is prohibited.
- Please use charging equipment that complies with local standards when charging the vehicle. Otherwise, it may result in a charging failure or cause damage to the vehicle, the charging equipment, or personal injury.
- Do not charge the vehicle in heavy rain or extreme weather conditions. Doing so may result in a charging failure or cause damage to either the vehicle or the charging equipment.
- Before charging, please check the charging connector and the vehicle's charge port for any deformation, burn marks, or erosion. If any abnormality is found, do not charge the vehicle. Otherwise, it may result in damage to the vehicle, the charging device, or personal injury. Please contact NIO if necessary.
- Before charging, please check the charging connector and the vehicle's charge port for any dirt or foreign matter. The connector should be kept clean

and failure to do so may result in a charging failure or damage to the vehicle's charge port.

- If the charging equipment malfunctions, please contact the charging equipment manufacturer. Do not attempt to fix it yourself.
- After rain, please check if there is water in the charge port before charging the vehicle. Do not charge the vehicle when there is an obvious indicator of water in the charge port. Doing so may result in a charging failure or cause damage to either the vehicle or the charging equipment.
- Do not use high pressure washers to clean the charge port while charging. Doing so may result in a charging failure or cause damage to either the vehicle or the charging equipment.
- During fast charging, patients who are dependent on cardiac pacemakers should stay away from the vehicle in order to avoid electromagnetic interference between the cardiac pacemaker and the charging equipment. .
- If the vehicle has a peculiar smell or emits smoke while charging, stop charging and contact NIO immediately.
- Do not remove the charging connector before charging is completed. Doing so may cause an electric arc.

### Caution

If the environmental temperature is too high or too low, the charging time will be affected. If the vehicle is kept in a low temperature environment for a long period of time, the battery capacity will be affected.



## Charging

You can charge your vehicle with Power Home or a public charger.

### ***Charging Process***

1. Shift into PARK, press the charge port cover or swipe right on the center display, and tap **Charge Port** so that the charge port cover deploys automatically. The charge port indicator is in solid white.

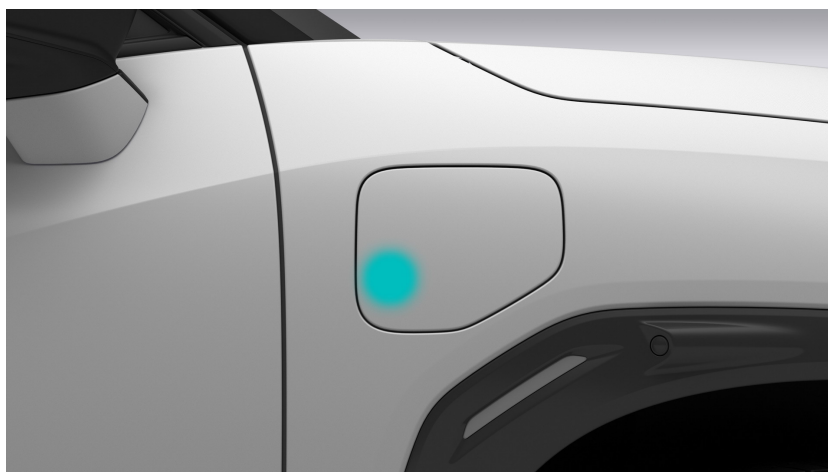

### **Caution**

Do not forcefully adjust the charge port cover when it is active or open. Doing so may damage the cover.

2. Check if the charging equipment and connector are in good condition and plug the charging connector into the charge port on the vehicle. At this time, the charge port and charging connector start pairing. A blue charge port indicator will light up to indicate the charge port is operating correctly. If the charge port and charging connector fail to pair correctly or pairing times out, the indicator will flash blue and then go out. In this case, plug the charging connector again.

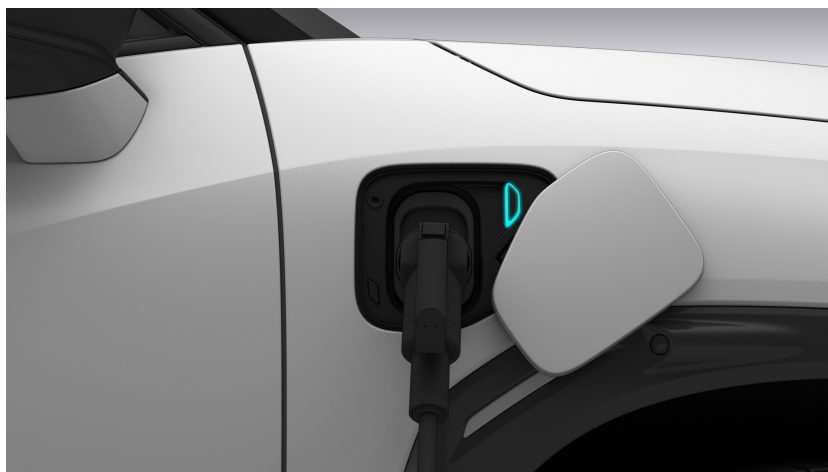

3. Power on the charging equipment to start charging. You can check the current charging status by tapping **My EL7 > Battery** on the center display or the NIO app. A blue charge port indicator will light up to indicate the current charging progress.
4. If you need to stop the charging manually, you need to unlock the vehicle and stop the charging by tapping **My EL7 > Battery** on the center display. Then, remove the charging connector after the charge port indicator turns solid green.

When charging completes, you need to press the Unlock button on the charging connector before removing the charging connector.



### Caution

- In the process of DC fast charging, you can unlock the vehicle first, and then press and hold the OFF button at the charging port to manually stop charging.
- When inserting and removing the charger, please face the charging socket. If the charger is stuck, try to lift it slightly. Do not forcibly shake the

charger while inserting or removing it to prevent the charger or charging socket from being damaged.

5. If the charge port indicator flashes red during the charging process, try another charger. If it continues to flash red, stop charging immediately and contact NIO.



6. After removing the charging connector, press the charge port cover down, press the Close button near the charge port or tap **Charge Port** on the center display to close the charge port cover automatically.

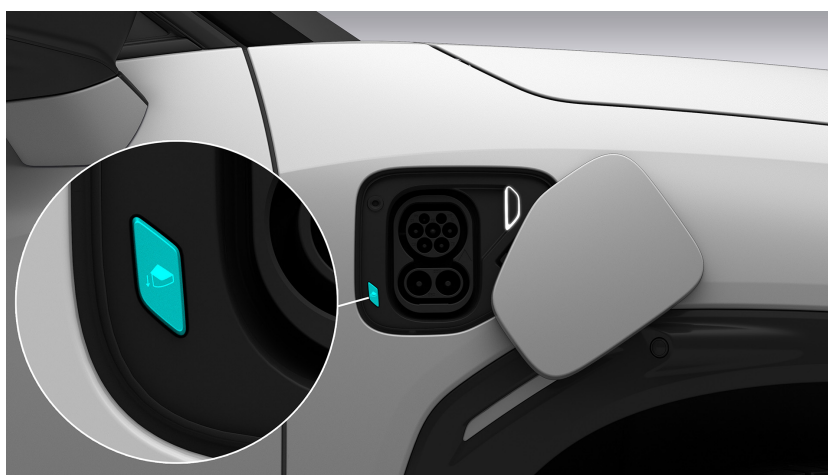

### Note

When charging the vehicle using NIO Power Home, the charge port cover will automatically open when you take off the charging connector from the charger and will automatically close when you remove the connector from the vehicle. If the charge port cover catches the charging connector while closing automatically, press and hold the Close button for five seconds, after which it will open automatically.

### When Unable to Remove the Connector

If the charging connector cannot be removed after the vehicle is unlocked, please try the following steps:

1. Ensure that the charging connector unlock button is popped up by firmly plugging the connector in, lock and then unlock the vehicle again, press and hold the charging connector unlock button for one to two seconds, and then unplug the connector after the indicator on the charge port turns solid green.
2. If the problem persists, please stop charging immediately and contact NIO.

## Battery Level and Charging Display



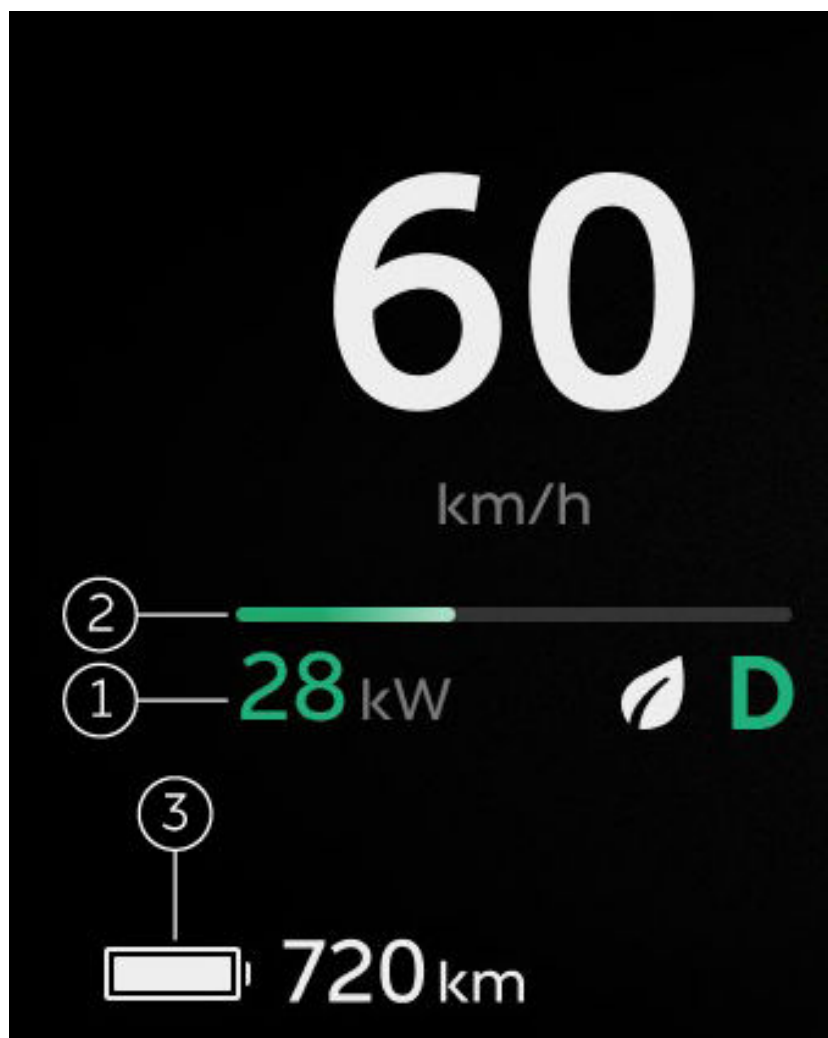



The state of the high voltage battery and battery-related warning messages are displayed on the digital instrument cluster.



1. Current power  
Indicates the current power of the high voltage battery or power gained through regenerative braking.
2. Energy bars  
The blue energy bar indicates the power of the high voltage battery. The green energy bar indicates the power gained through regenerative braking.
3. Remaining range  
Indicates the estimated driving range available.  
When the remaining driving range is less than 60 km, the icon will turn yellow; when the remaining driving range is less than 10 km, the icon will turn red.

You can press the menu button on the right side of the steering wheel and select "Vehicle Info" to check the current and voltage of the high voltage battery.

The battery-related indicators on the digital instrument cluster are:

Indicator	Note
	<p>Low battery level Indicates that the high voltage battery level is low. Please promptly charge the battery or contact NIO when necessary.</p>
	<p>High voltage battery cutoff Indicates that the vehicle's high voltage power is off. Please contact NIO when necessary.</p>
	<p>12V battery charging fault Please contact NIO immediately when this indicator lights up.</p>
	<p>High voltage battery fault Please stop the vehicle and contact NIO immediately when this indicator lights up.</p>
	<p>High voltage battery overheat Please stop the vehicle and contact NIO immediately when this indicator lights up.</p>
	<p>Icy/Snowy road Indicates that the current ambient temperature is too low and may affect high voltage battery performance.</p>
	<p>Charging cable connected Indicates that a charging cable is connected.</p>

## Battery Warmup

The charging speed of high-voltage batteries slows down in cold conditions such as winter. When the Battery Warmup function is enabled, the high-voltage battery can be warmed up to a certain extent in advance before the vehicle reaches the energy replenishment point (charging pile ) to improve the charging speed of the vehicle.

### ***Low-temperature charging warmup***

The low-temperature charging warmup function is enabled by default. You can go to the Settings page from the far left side of the control bar at the bottom of the central display, and select to enter the **Battery** page to disable the function. After this function is enabled, when the destination or passing point in the navigation state is the charging station , the vehicle will automatically start the high-voltage battery warmup on the premise that it can ensure arrival at the destination, so as to improve the charging efficiency. Low-temperature charging warmup only advances the battery warming step and does not waste additional charging energy.

In the navigation state, the low-temperature charging warmup function will be automatically activated under the following conditions. The current warmup status will be displayed on the status bar at the top of the central display:

- The navigation destination or passing point is a Charging Station , or a service area with a Charging Station .
- The driver is seated.
- The current driving range is more than 120 km.

You can manually disable the low-temperature charging warmup function by selecting "Disable This Time" (enabled by default next time) or "Keep Disabled".

This function will automatically deactivate the warmup process (the switch remains on) in one of the following conditions:

- Connect a charger.
- Turn off the navigation or stop navigating to the Charging Station .
- The current driving range does not support a warmup to the destination with 20 km remaining.

### ***Manual charging warmup***

The manual charging warmup function is disabled by default. If you are familiar with the charging route and do not need to follow the navigation guide to the charging point, it is recommended to enter the **Battery** page on the central display in a low temperature environment and enable the manual charging warmup function. The vehicle will enable the high-voltage battery warmup to improve charging efficiency.

You can enable or disable the manual charging warmup function on the central display . The status bar at the top of the central display displays the current warmup status.

This function will automatically deactivate the warmup process (the switch is off now) in one of the following conditions:

- Connect a charger.
- The low-temperature charging warmup function is enabled.
- The battery has been warmed up to the set temperature and maintained for 1 hour.

### **Caution**

- Enabling Battery Warmup may consume some power. Please plan your travel properly or turn it off as needed.
- When Low-Temperature Battery Warmup is activated, manual preconditioning will not be available.
- Manual Battery Warmup cannot determine the remaining range with preconditioning turned on. Please make sure that the power is enough for the trip to the destination before turning on this feature.



## High Beams and Low Beams

You can set high beams and low beams with the light control lever on the left of the steering wheel.



- Push the lever away from you to turn on Auto High Beams. Push the lever again to turn on the high beams.
- Toggle the level backward to turn off the high beams; Toggle the level backward repeatedly to flash the high beams.

### Note

Auto High Beams are only available when the headlights are set to the Auto mode or the feature is turned on.

## Turn Signals

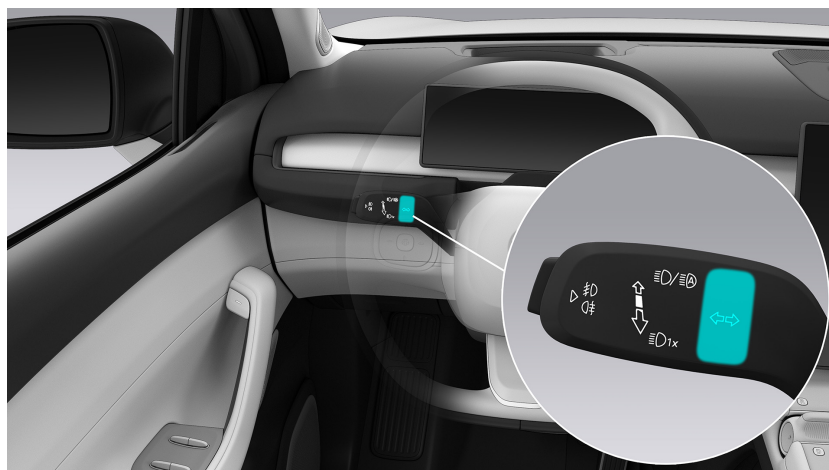

- Left: Toggle the lever down
- Right: Toggle the lever up

The turn signals stop operating when the steering wheel returns to the center position or the lever is moved back to the center.

When a turn signal is on, the corresponding icon lights up on the digital instrument cluster with clicking sounds.

## Fog Lights

Press the button on the end of the left lever to turn on the front and rear fog lights. Position lights are automatically turned on when the fog lights are on.



Sequence:

- First press: Front fog lights on.
- Second press: Rear fog lights on.
- Third press: Rear fog lights off.
- Fourth press: Front fog lights off.

Press again to repeat the sequence.

When the fog lights are on, the corresponding icon will be displayed on the digital instrument cluster.

## Welcome Lighting

When you or an authorized user carries an authenticated smart key fob or a mobile phone with the BLE Unlock & Start feature enabled and approaches the vehicle at a maximum distance of 7-10 meters, the low beams and position lights will automatically turn on to welcome you. At this time, the vehicle will match your account information and automatically retrieve your custom settings to make corresponding adjustments in advance before you unlock and open the door, such as seat settings, climate settings, media settings, and interior light settings.

## Exterior Door Handle Courtesy Lights

Each exterior door handle is equipped with a light. When the vehicle is unlocked, the door handles automatically extend and the lights turn on to illuminate the surrounding environment.

## Reading Lights

### ***Automatic Control of Reading Lights***

When you unlock the vehicle or open any door (or tailgate), the reading lights will be turned on automatically to illuminate the cabin. The reading lights will be turned off automatically if any of the following conditions are met. In this case, you can turn on the reading lights by touching the switch on the headliner.

- The vehicle is being driven.
- The vehicle is locked from the outside.
- A door is open for over 10 minutes.
- All doors are closed for over 15 seconds.

### **Note**

When the vehicle is not locked from the outside and you turn on a front reading light by touching the switch on the headliner, the reading light can only be turned off manually.

Enter Settings from the bottom of the center display, and tap **Lights > Auto Reading Lights** to automatically turn on/off the reading lights.

### ***Manual Control of Reading Lights***

You can manually turn on the reading lights to illuminate the cabin when placing objects, viewing a map, or reading documents. Touch switches controlling the reading lights are located on the front headliner. To turn a reading light on/off, touch the corresponding switch; To turn all of the reading lights on/off, enter Settings from the bottom of the center display, tap **Lights > Reading Lights**.

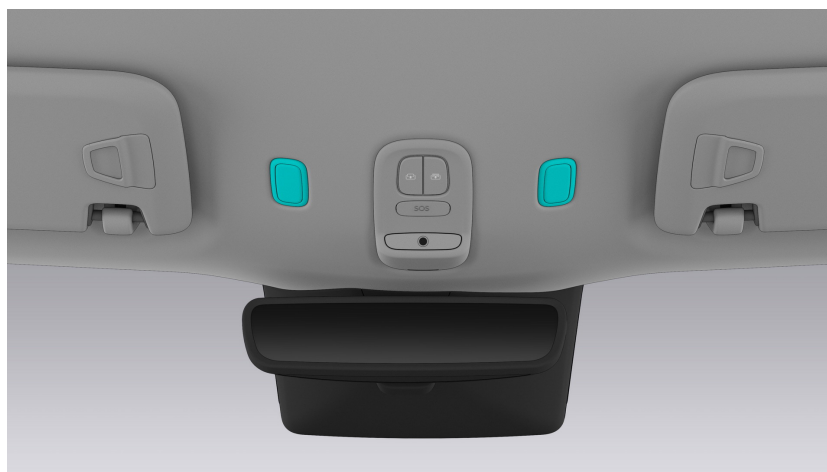

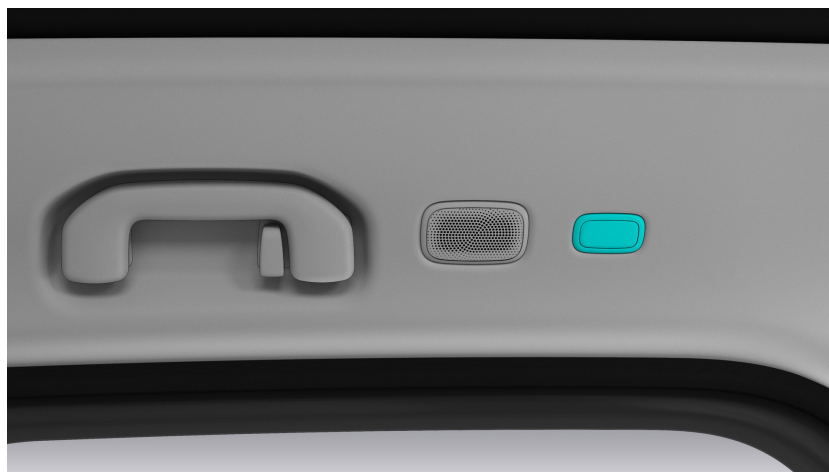

When the vehicle is locked from the outside (with a smart key fob or the NIO app), all reading lights will be turned off.

**Note**

If a front reading light is turned on via the touch switch on the headliner, the reading light cannot be controlled by the master switch and will need to be turned off manually; if the front reading lights are off, you can control both front and rear reading lights using the master switch.

## Puddle Lights

There are one puddle light under each door and two puddle lights on the tailgate. The puddle lights illuminate the ground at night to prevent you and passengers from stepping into a puddle.

The puddle light turns on when a corresponding door or the tailgate is opened and turns off after it remains open for 10 minutes or is closed.

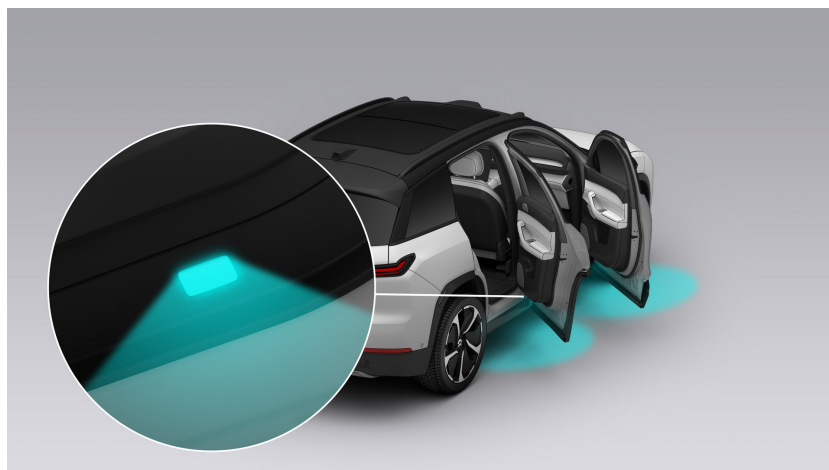



## Smart Ambient Lights

The smart ambient lights are located on the door panels, storage areas, and floor to adjust modes. You can set your preferred ambient lighting effect and enjoy the delightful atmosphere it creates.



You can turn on ambient lighting on the center display. In this case, the default ambient lighting effect for the current drive mode will be turned on. Swipe right on the home page to visit Quick Access, tap **Ambient Lighting** to choose your desired color and brightness for ambient lighting in different positions (doors, storage areas and floor), which will be saved to your settings. You can also set different ambient lighting modes, such as Breathing and . This setting will be saved on the center display.

## Illuminated Door Sill Inlays

In order to provide a delightful entry and exit, when any door is opened, the door sill inlay of the corresponding door will light up to illuminate the cabin and surrounding environment.



## Vanity Mirror Lights

Vanity mirrors are provided on the two sun visors on the front headliner. The vanity mirrors are automatically illuminated when opened.

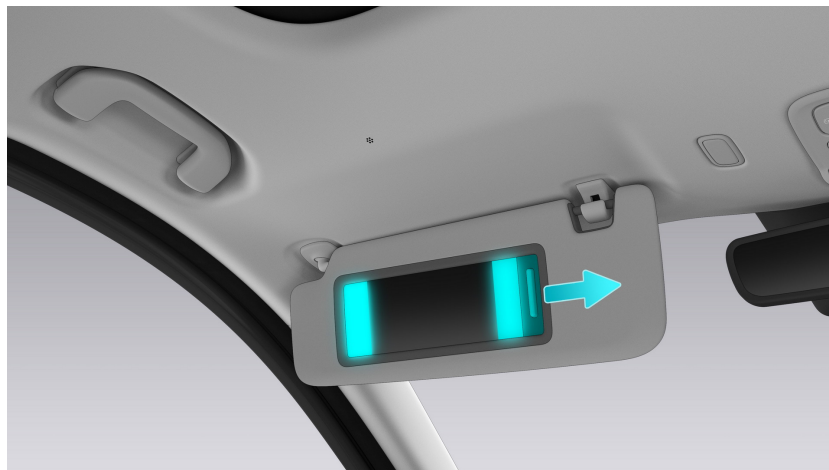

## Follow Me Home

The vehicle is equipped with the Follow Me Home feature. When you lock your vehicle and are ready to leave it at night, the low beams and position lights will turn on to illuminate the road ahead for you. Enter Settings from the bottom of the center display, and tap **Lights > Courtesy Headlights** to set how long the Follow Me Home Lighting stays on after vehicle locking.

## Minimal Lighting

When the vehicle is in PARK, you can enter Settings from the bottom of the center display and tap **Lights > Lighting** to turn on Minimal Lighting. All the ambient lights and reading lights inside the vehicle and the headlights outside the vehicle will turn off.

If you manually turn off Minimal Lighting, the lighting will restore to the previous mode.

When Minimal Lighting is on, if you manually adjust the exterior lights, ambient lights, and reading lights, Minimal Lighting will be automatically turned off.

## Search Lighting

You can enter Settings from the bottom of the center display and tap **Lights > Lighting** to turn on Search Lighting. All the ambient lights and reading lights inside the vehicle and the headlights outside the vehicle will turn on and their brightness will be automatically adjusted to the maximum, making it convenient for you to search for items in the vehicle.

If you manually turn off Search Lighting, the lighting will restore to the previous mode.

When Search Lighting is on, if you manually adjust the exterior lights, ambient lights and reading lights, Search Lighting will be automatically turned off.

## Night Lighting

You can enter Settings from the bottom of the center display and tap **Lights > Lighting** to turn on Night Lighting. The ambient lights on the floor will turn on a warm yellow shimmer, and the ambient lights and reading lights on doors and storage areas will turn off to provide a comfortable sleeping environment.

If you manually turn off Night Lighting, the lighting will restore to the previous mode.

When Night Lighting is on, if you manually adjust the exterior lights, ambient lights and reading lights, Night Lighting will be automatically turned off.

## Trunk Lighting

When you open the tailgate, the trunk lighting will automatically light up.

The trunk lighting will automatically be turned off when closing the tailgate or after 10 minutes.



## Linking Key Fob to Account

When the vehicle is activated and verified for the first time, the owner's account will be linked to the key fob by default. When the vehicle is unlocked with one of the key fobs, the vehicle will log into the owner's account automatically.

Owner can also link an authorized user account to a smart key fob by managing the key fob in the NIO app. When an authorized user unlocks the vehicle using a key fob, the vehicle will log into the linked user's account automatically. You can view and delete accounts linked to the key fobs on the NIO app. After linking or unlinking a account successfully, the vehicle owner and the account owner will receive a message and an app notification.

### Note

- Only the vehicle's owner can manage key fobs linked to the owner's account. Other users must be authorized by the vehicle owner before linking the corresponding account to the key fob.
- If the vehicle's owner terminates the authorization, the user account will be unlinked from the smart key fob automatically.
- Guest Mode only applies to the smart key fobs linked with the owner's account. If you unlock the vehicle using a key fob linked with an authorized user account, the vehicle will automatically load the information of the authorized user.

## Switching Accounts

You or an authorized user can switch between user accounts on the center display to load the corresponding settings (for example, seat, steering wheel, **HUD settings**, etc.).

You, a co-user or an authorized user can switch between user accounts on the center display and load the corresponding settings in either of the following two ways:

1. When the vehicle is connected to the network, or there is currently no network available but you have logged in in the past, tap the profile photo on the center display or **Account > Switch Accounts** in Settings to view a list of all the valid accounts (including the owner's account, co-user accounts, and authorized user accounts). Tap the corresponding profile photo or user name to switch to the account, and log in with this account after verification (by scanning the QR code with the NIO app or entering the verification code received on your phone). You can also enable Passwordless Login in **Accounts > Face ID and Password** for easy login and account switch.
2. To switch accounts automatically through face recognition, tap your profile photo on the center display or **Settings > Account > Face ID and Password**, and enter face recognition data to enable this feature. After you unlock the vehicle and enter the driver's seat, look straight ahead, and the vehicle will automatically recognize the corresponding account information and load the corresponding custom settings. If the recognized user's face doesn't match the current account, but matches another valid account (for example, this may happen if you've lent the key fob to a family member), the vehicle will automatically switch the account to match the current user.

### Caution

- You can only switch accounts when the vehicle is not being driven.
- In Guest Mode, the vehicle will not save any customized settings (such as the driver's seat position).

## Authorized Unlocking

If you want to lend your vehicle to others, you can authorize users registered on the NIO app. An authorized user can access authorized features by using their NFC key or verified NIO app.

### ***Owner Authorization***

Go to the Settings page of the NIO app or tap **Account > Account Settings** in the upper left corner of the center display, and then enter the gesture password of your vehicle to go to the authorization management page.

You can authorize a user and set authorization by entering his/her NIO app user name. Up to nine users can be authorized. After setting the user's authorization, tap the profile photo or user name to view the user's information and authorization details (e.g. media, video, safe box). If the current authorization is active, you can also edit the scope of authorized access or disable the user's authorization. An authorized user can only access authorized features, and cannot manage authorization or set Guest Mode.

If you unlock the vehicle using your smart key fob, the vehicle will automatically log into the owner's account.

### **Note**

For safety reasons, if you cancel authorization when an authorized user is driving the vehicle, it won't take effect until the authorized user stops and locks the vehicle.

### **Note**

If the authorized user has a NIO account, the authorization will take effect immediately after it is completed. If the authorized user doesn't have a NIO account, the authorization will become effective only after the user registers a NIO account.

### ***Unlocking by An Authorized User***

An authorized user can unlock the vehicle using their NFC key or remote control on the NIO app. To view the account and access of an authorized user, tap his/her profile photo on the center display.

- NFC unlocking: Open the NFC app on your phone and place it close to the B pillar on the driver's side.

- NIO app remote unlocking: Choose **My Vehicle** > **Doors** on the NIO app.

## Guest Mode

If you want to lend the vehicle to others by giving them a smart key fob, tap your profile photo on the center display and choose Guest Mode to protect your privacy (e.g. navigation history, contacts, videos, photos). Only default features such as climate control, weather and navigation (with no access to History or Favorites) are available to guests.

With the Guest Mode on, the vehicle will show the features exclusive to the Guest Mode after the vehicle user unlocks and enters the vehicle by using the smart key. To exit the Guest Mode, enter the gesture password of the vehicle.

### Caution

1. You can only set Guest Mode when the vehicle is not being driven.
2. If a smart key fob is linked to the owner's account and your vehicle is not in Guest Mode, the vehicle will automatically log into the owner's account when a user unlocks the vehicle using a smart key fob.

## Service Authorization

You or an authorized user can send a service request to NIO on the NIO app. NIO manages and authorizes service specialists to temporarily access the vehicle and conduct the requested service (e.g. One Click for Power). NIO retrieves the authorization after the service is completed.

After obtaining authorization, service specialists can unlock the vehicle using an NFC key within a specified time frame and use authorized features. The center display shows the account information of the authorized service specialist and the authorized features available to them. Authorized service specialists cannot manage authorization, set Guest Mode, link the vehicle to a key fob, or switch accounts.

### Caution

After the service is completed, all doors and the liftgate should be locked. If a door or the liftgate is not locked, you will be notified on the NIO app.

## Driver Seat Memory

You can enter Settings from the bottom of the center display, and tap **Position Adjustment > Driver Seat > Position Memory** to customize your settings. The driver's seat, steering wheel, side mirrors, and **HUD height** will automatically adjust to your or the authorized user's preferred settings saved to the corresponding account. After adjusting the seat position and backrest, go to Driver Seat Memory and choose **Drive, Alternate or Relax** to customize and save the settings to the corresponding user account.

After unlocking the vehicle and sitting in the driver's seat (with the driver's door closed), retrieve the latest driver's seat settings by swiping right on the home page to visit Quick Access, or going to Driver Seat Memory and selecting Drive, Alternate, Relax or Other.

If you or an authorized user manually adjusts the settings (e.g. driver's seat position) while using the vehicle, press and hold the corresponding seat icon on the center display to update the settings, which will overwrite the existing settings to the corresponding account.

### Warning

Do not adjust the seat's position while driving. Doing so may result in an accident.

### Caution

- Before initializing the driver's seat memory, ensure that the vehicle is in PARK in a safe environment, the seat and steering wheel are clear of obstacles, and the rear seats are unoccupied. Please also lower the seat height, and adjust the headrest to the lowest position to avoid damaging the headliner.
- While driving, do not operate any buttons on the memory interface on the center display to adjust the driver's seat, steering wheel or side mirrors and be mindful of your safety.

## Steering Wheel Memory

You can enter Settings from the bottom of the center display, and tap **Position Adjustment > Driver Seat > Position Memory** to customize your settings. After adjusting the steering wheel, go to Driver Seat Memory and choose **Drive, Alternate or Relax** to customize and save the settings to the corresponding user account.

After sitting in the driver's seat (with the driver's door closed), go to Driver Seat Memory and choose Drive, Alternate, Relax or Other, after which the steering wheel will automatically adjust to the latest settings saved in the corresponding account.

If you or an authorized user manually adjusts the settings (e.g. steering wheel position) while using the vehicle, press and hold the corresponding position icon on the center display to update the settings, which will overwrite the existing settings saved to the corresponding account.

### Warning

- Do not adjust the steering wheel position while driving. Doing so may result in an accident.
- An improper steering wheel position or seating position may result in injury. Make sure your chest is at least 25 centimeters from the steering wheel.

### Caution

- Before initializing the driver's seat memory, ensure that the vehicle is in PARK in a safe environment, the seat and steering wheel are clear of obstacles, and the rear seats are unoccupied. Please also lower the seat height, and adjust the headrest to the lowest position to avoid damaging the headliner.
- While driving, do not operate any buttons on the memory interface on the center display to adjust the driver's seat, steering wheel or side mirrors and be mindful of your safety.



## Side Mirror Memory

You can enter Settings from the bottom of the center display, and tap **Position Adjustment > Driver Seat > Position Memory** to customize your settings. After adjusting the driver's side or passenger side mirror, go to Driver Seat Memory and choose **Drive, Alternate or Relax** to customize and save the settings to the corresponding user account.

After sitting in the driver's seat (with the driver's door closed), go to Driver Seat Memory and choose Drive, Alternate, Relax or Other, after which the side mirrors will automatically adjust to the most recent settings saved in the corresponding account.

If you or an authorized user manually adjusts the settings (e.g. side mirror position) when using the vehicle, press and hold the corresponding position icon on the center display to update the settings, which will overwrite the existing settings saved to the corresponding account.

### Warning

Do not adjust the side mirrors while driving. Doing so may result in an accident.

### Caution

- Before initializing the driver's seat memory, ensure that the vehicle is in PARK in a safe environment, the seat and steering wheel are clear of obstacles, and the rear seats are unoccupied. Please also lower the seat height, and adjust the headrest to the lowest position to avoid damaging the headliner.
- While driving, do not operate any buttons on the memory interface on the center display to adjust the driver's seat, steering wheel or side mirrors and be mindful of your safety.

When the vehicle is in REVERSE, the side mirrors will automatically tilt down to provide a better view during reverse parking. You can go to Settings from the leftmost side of the control bar at the bottom of the center display, and tap **Driving > Auto-Tilt In Reverse** to enable this feature. When the side mirrors tilt down, you can adjust their positions. The new positions will be automatically saved to the corresponding account (this means that you don't have to manually save the settings on the center display). The side mirrors will automatically tilt down to the saved positions the next time the vehicle is in REVERSE. The side mirrors will revert back to Drive Position when the vehicle is not in REVERSE.

**Caution**

When the side mirrors are automatically tilting to a saved position, if you adjust a side mirror manually, the side mirrors will stop tilting and save the new position to the corresponding account.

## Passenger Seat Memory

To set the front passenger seat memory, shift into PARK, Enter Settings from the bottom of the center display, and tap **Position Adjustment > Front Passenger Seat > Position Memory** to customize your settings (default position cannot be customized). After adjusting the seat position, go to Passenger Seat Memory and choose **Frequent, Alternate, or Relax** to customize and save the settings to the corresponding user account.

To retrieve the latest passenger seat settings after sitting in the front passenger seat, press the corresponding seat icon on the center display.

If you or an authorized user manually adjusts the front passenger seat while using the vehicle, press and hold the corresponding seat icon on the center display to update the settings, which will overwrite the existing settings to the corresponding account.

### Caution

Before initializing the driver's seat memory, ensure that the vehicle is in PARK in a safe environment, the seat is clear of obstacles, the footrest is stowed, and the rear seat is unoccupied. Please also lower the seat height, and adjust the headrest to the lowest position to avoid damaging the headliner.

## Driver Seat Adjustment

### ***Adjusting Seat Position with Buttons***

You can adjust the position of the driver seat, which is a 14-way adjustable seat with a 4-way power lumbar support and a 4-way power headrest.



1. Cushion length  
Toggle this switch forward and backward to adjust the cushion length.
2. Cushion height  
To move the seat up or down, toggle the switch in the corresponding direction.
3. Adjusting seat position  
To move the seat forward or backward, toggle the switch in the corresponding direction.  
Seat height  
Toggle up and down in the middle of this switch to increase or decrease the seat height.
4. Backrest inclination  
Toggle the switch forward or backward to adjust the backrest.
5. Lumbar support adjustment  
To adjust the lumbar support, press the corresponding button on the switch.

### **Warning**

- Before seat adjustment (forward and backward, height, backrest, etc.), make sure that there is sufficient safe space for the seat and children, occupants, and pets in the rear row to avoid squeezing or smacking into children, occupants, and pets in the rear row.

- Adjust the driver's seat position and headrest when the vehicle is in PARK. Seat position and other adjustments while driving may cause safety risks.
- During seat adjustment (forward and backward, height, backrest, etc.), avoid putting your hands or other parts of the body on the seat movement path to prevent pinching and colliding.
- Ensure that the seat is locked after position adjustment.
- Children should not adjust the seat for there is a risk of being caught.
- When Easy Entry is turned on, make sure that there is enough safe space for children, occupants, and pets in the front and rear rows to prevent the seat from squeezing or smacking into them when moving.
- Do not start the vehicle until the Easy Entry feature is finished safely. Any operation before that may cause the vehicle to lose control and cause accidents.
- It is recommended to turn off Easy Entry if there are often children passengers in the rear row.

### ***Controlling Seat Movement via the Center Display***

You can control the movement of the driver seat from the center display.

On the driver seat control page on the center display, tap the control arrows for Position, Backrest, and Cushion to adjust the position of the driver seat, the backrest folding angle, and the position of the cushion.

The center display provides five positions: Drive, Relax, Exit, and two Alternate positions. Each position needs to be set individually.

#### **To set the memorized positions:**

Enter Settings from the bottom of the center display, and tap **Position Adjustment > Driver Seat** to set the position of the driver seat. When setting the position for the first time, adjust the seat position using the seat buttons or the center display, and set customized positions for different scenarios. Select **Drive/Relax/Exit/Alternate**. The settings will then be automatically saved to the corresponding user account. To update a position, just press and hold the corresponding button to reset when the seat is in the desired position.

### ***Correct Sitting for the Driver***

To minimize potential risks and keep you safe, adjust the seat as follows:

- Move the seat forward or backward to the appropriate position, and make sure that the accelerator pedal and the brake pedal can be easily pressed.
- Adjust the seat backrest to a suitable straight-backed position, and make sure that the back fits perfectly with the backrest and that the backrest angle is not too large.
- Adjust the seat to a suitable height when two hands can comfortably hold the steering wheel.
- Adjust the steering wheel, and make sure a clearance of at least 25 cm between the driver's chest and the steering wheel.
- Adjust the headrest, and make sure that the headrest center and the driver's eyes are on the same level.
- Place the middle part of the seat belt between the neck and shoulders. Tighten the lower part of the belt around the hip (not the abdomen).

### Warning

- Do not use seat cover of any kind or modify the seat surface by yourself. Seat covers or modified seat surfaces may cover up the airbags in the seat, thus minimizing protection for the driver and passengers, with a higher risk of injury.
- Do not place any objects under the seat. There may be safety risks during seat adjustment, collision, or sudden acceleration/deceleration.
- Do not hang other objects (such as clothes hangers) on the seat or headrest. In case of collision, sudden acceleration or deceleration, such objects may add to the risk of injury.
- One seat can only be occupied by one passenger while driving. Infants or children should not share a seat and seat belt with an adult or sit on the lap of an adult. In case of collision, sudden acceleration or deceleration, such postures may pose a safety risk and cause injury to occupants, infants, and children.
- Headrests for front and rear seats should not be switched, otherwise, the headrests may not be adjusted to the correct height and position. This will increase the risk of head and neck injuries in case of accidents or emergency braking.
- An excessive backrest angle may result in serious injury in case of collision. Refer to the correct seat position recommended.

- Individuals with limited pain perception due to illness, ages, or other conditions should use the temperature control system and seat heating carefully to avoid potential low-temperature burns due to prolonged use.

## Passenger Seat Adjustment

### ***Adjusting Seat Position with Buttons***

The front passenger can adjust the seat. The power passenger seat is a 14-way adjustable seat with a 4-way power lumbar support and a 4-way power headrest.

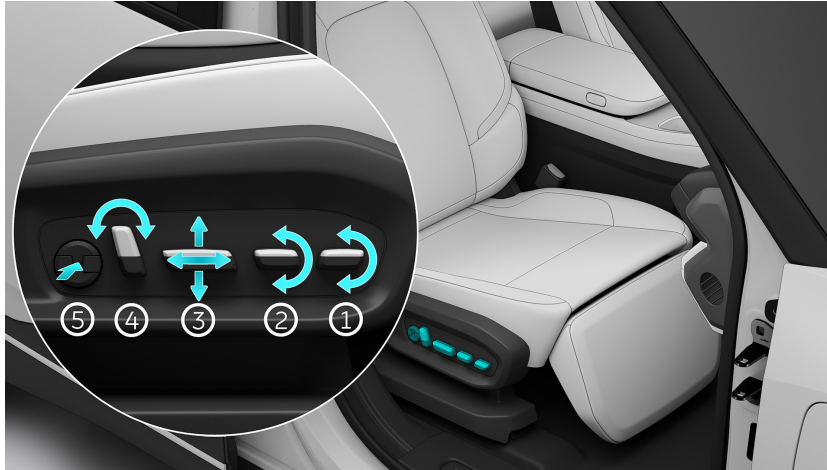

1. Footrest adjustment  
Toggle the switch up and down to adjust the footrest.



2. Leg support adjustment  
To move the leg support up or down, toggle the switch in the corresponding direction.





### 3. Adjusting seat position

To move the seat forward or backward, toggle the switch in the corresponding direction.

Seat height

To move the seat up or down, toggle the switch in the corresponding direction.

### 4. Backrest adjustment

Toggle the upper end of the switch forward or backward to adjust the backrest.

### 5. Lumbar support adjustment

To adjust the lumbar support, press the corresponding button on the switch.

## Warning

- Before seat adjustment (forward and backward, height, backrest, etc.), make sure that there is sufficient safe space for the seat and children, occupants, and pets in the rear row to avoid squeezing or smacking into children, occupants, and pets in the rear row.
- Adjust the passenger seat position and headrest when the vehicle is in PARK. Seat position and other adjustments while driving may cause safety risks.
- During seat adjustment (forward and backward, height, backrest, etc.), avoid putting your hands or other parts of the body on the seat movement path to prevent pinching and colliding.
- Ensure that the seat is locked after position adjustment.
- Children should not adjust the seat for there is a risk of being caught.
- When Easy Entry is turned on, make sure that there is enough safe space for children, occupants, and pets in the front and rear rows to prevent the seat from squeezing or smacking into them when moving.

- Do not start the vehicle until the Easy Entry feature is finished safely. Any operation before that may cause the vehicle to lose control and cause accidents.
- It is recommended to turn off Easy Entry if there are often children passengers in the rear row.

### ***Controlling Seat Movement via the Center Display***

Passengers can control the movement of the front passenger seat from the center display.

On the front passenger seat control page on the center display, tap the control arrows for Position, Backrest, and Footrest to adjust the position of the front passenger seat, the backrest folding angle, and the position of the footrest.

The center display provides four positions: Default, Frequent, Relax, and Alternate. Among them, the Default position cannot be changed, and the Frequent, Relax, and Alternate positions need to be set individually.

**To set the memorized positions:**

- Enter Settings from the bottom of the center display, and tap **Position Adjustment > Front Passenger Seat** to set the position of the front passenger seat. When setting the position for the first time, adjust the seat position using the seat buttons or the center display, and set customized positions for different scenarios. Select **Frequent/Relax/Alternate**. The settings will then be automatically saved to the corresponding user account. To update a position, just press and hold it to reset when the seat is in the desired position.
- Swipe right from the left side of the home page on the center display to enter the Quick Settings page, and tap **Passenger Seat Adjustment** to directly enter the front passenger seat adjustment page. The adjustment method is as described above.

### ***Controlling Seat Movement via the Rear Display***

Passengers in the rear can control the movement of the front passenger seat from the rear display.

Swipe down from the top of the rear display to enter the Quick Settings page. Two buttons are provided: Rear Premium and Reset Front Passenger Seat.

- Rear Premium: Move the front passenger seat to the Rear Premium position.

- Reset Front Passenger Seat: Restore the front passenger seat to its default position.

### ***Correct Sitting for the Front Passenger***

To minimize potential risks and keep you safe, adjust the seat as follows:

- Move the seat forward or backward to the appropriate position, and put both feet in front of the seat.
- Adjust the seat backrest to a suitable straight-backed position, and make sure that the back fits perfectly with the backrest and that the backrest angle is not too large.
- Adjust the headrest, and make sure that the headrest center and the passenger's eyes are on the same level.
- Place the middle part of the seat belt between the neck and shoulders. Tighten the lower part of the belt around the hip (not the abdomen).

### **Warning**

- Do not use seat cover of any kind or modify the seat surface by yourself. Seat covers or modified seat surfaces may cover up the airbags in the seat, thus minimizing protection for the driver and passengers, with a higher risk of injury.
- Do not place any objects under the seat. There may be safety risks during seat adjustment, collision, or sudden acceleration/deceleration.
- Do not hang other objects (such as clothes hangers) on the seat or headrest. In case of collision, sudden acceleration or deceleration, such objects may add to the risk of injury.
- One seat can only be occupied by one passenger while driving. Infants or children should not share a seat and seat belt with an adult or sit on the lap of an adult. In case of collision, sudden acceleration or deceleration, such postures may pose a safety risk and cause injury to occupants, infants, and children.
- Headrests for front and rear seats should not be switched, otherwise, the headrests may not be adjusted to the correct height and position. This will increase the risk of head and neck injuries in case of accidents or emergency braking.
- An excessive backrest angle may result in serious injury in case of collision. Refer to the correct seat position recommended.

- Individuals with limited pain perception due to illness, ages, or other conditions should use the temperature control system and seat heating carefully to avoid potential low-temperature burns due to prolonged use.

## Rear Seat Adjustment

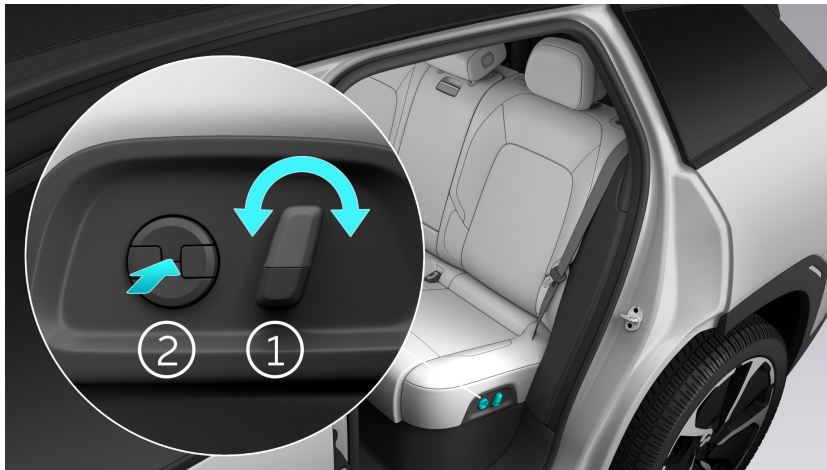

1. Backrest adjustment  
Toggle the upper end of the switch forward or backward to adjust the backrest.
2. Lumbar support adjustment  
To adjust the lumbar support, press the corresponding button on the switch.

### ***Correct Sitting for Rear Passengers***

- Lock the backrest in the upright position.
- Adjust the headrest, and make sure that the headrest center and the passenger's eyes are on the same level.
- Adjust the seat backrest to a suitable straight-backed position, and make sure that the back fits perfectly with the backrest and that the backrest angle is not too large.
- Put both feet in front of the rear seat.
- Place the middle part of the seat belt between the neck and shoulders, and tighten the lower part of the belt around the hip (not the abdomen).
- When riding with children, suitable child seats should be used to keep them safe. For details, refer to the child seat section.

### ***Folding Down Rear Row Backrests***



Pull the mechanical handle on the backrest and push forward to fold it down.

#### **Warning**

- When folding down the backrest of a rear seat, ensure that no objects are on the seat and its seat belt is not fastened. Failure to do so may result in damage to the third row seats.
- Ensure that the seat is locked before you start the vehicle (forward and backward, height, backrest, etc.). Otherwise, it may pose a potential risk of personal injury. (For example, if the rear seats are not fully locked after their backrests have been unfolded, it may increase the risk of personal injury in case of accidents or sudden acceleration or deceleration.)
- Do not sit on folded seats (for example, rear seats that are folded down) when the vehicle is moving. Otherwise, it may pose a risk of personal injury or death in case of collision and sudden acceleration or deceleration.

- When adjusting a rear seat backrest, ensure that the seat belt is not twisted or stuck in the backrest. Otherwise, the seat belt may be damaged and therefore pose a safety risk.

## Rear Premium

Enter Settings from the bottom of the center display, tap **Position Adjustment > Front Passenger Seat > Rear Premium**, and the front passenger seat will move to the most forward position.

Swipe down from the top of the rear display to enter the Quick Settings page. Tap **Rear Premium** and the front passenger seat will also move to the most forward position; tap **Reset Front Passenger Seat**, and the front passenger seat will be restored to the default position.



## Seat Headrest Adjustment

### ***Front Headrest Adjustment***

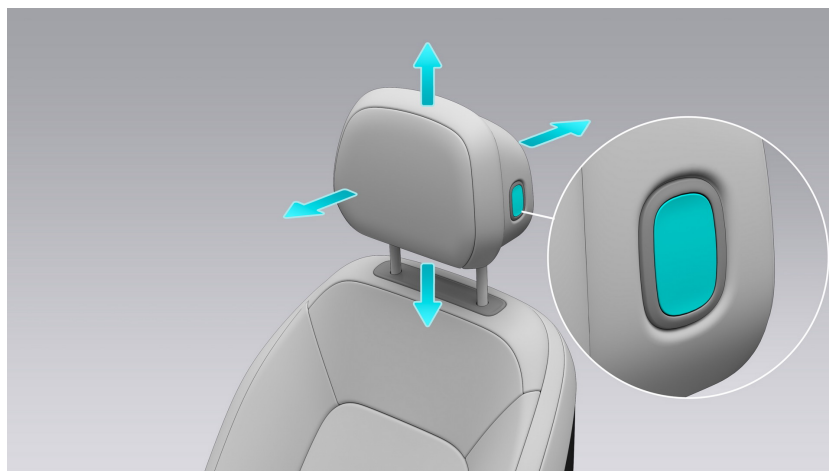

Front headrests can be adjusted at will. Press the Lock button to adjust the headrest backward, upward, or downward.

### ***Rear Headrest Adjustment***

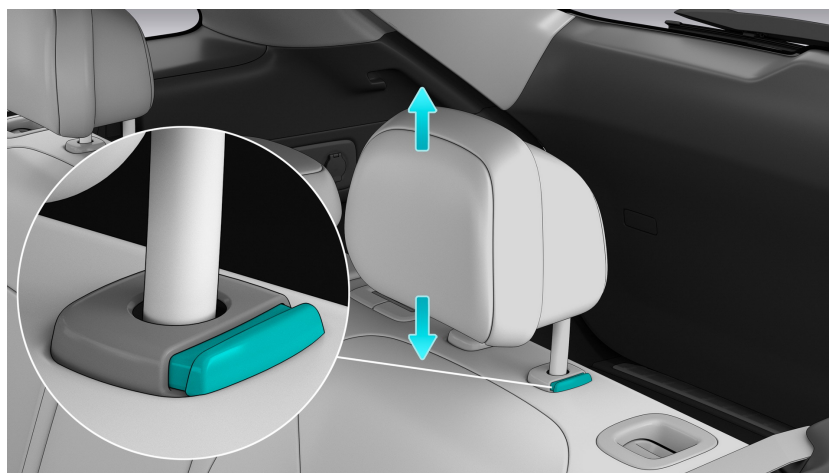

Press the button to adjust the headrest upward or downward.

### ***Rear Middle Headrest Adjustment***

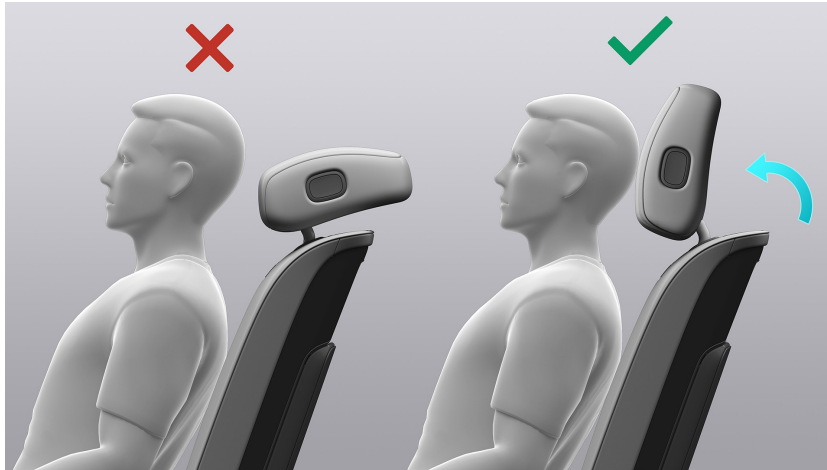

Press the Lock button to adjust the rear middle headrest.

Do not use the headrest when it is at its lowest position. To use it, pull the headrest upwards and ensure it is locked into place.

#### **Warning**

- To provide the best protection, make sure the headrest is set to an appropriate height according to the occupant's height.
- Do not use the headrest when it is at its lowest position. To use it, pull the headrest upwards and ensure it is locked into place.
- Adjust the seat headrest, and make sure that the headrest center and the occupant's eyes are on the same level.
- When the headrest is removed, do not drive the vehicle. In case of collision, sudden acceleration or deceleration, seats without headrests may not provide sufficient protection to the head, leading to serious consequences.

## Seat Massage

Lumbar massage is available for front seats and is set to off by default. Enter the Comfort page from the bottom of the center display, and tap **Seats > Massage** to select the desired massage mode (Mode 1, Mode 2, Mode 3, Mode 4, and Mode 5) and massage level (Level 1 and Level 2) for the corresponding seat.

- Mode 1: Catwalk
- Mode 2: Rolling
- Mode 3: Dynamic
- Mode 4: Waist
- Mode 5: Upper Back
- Level 1: Low
- Level 2: High

### Note

- With this feature on, the current level will be saved and the feature will turn off when the passenger leaves the seat for over 30 seconds;
- If someone is seated within 15 minutes after the passenger leaves, the feature will resume the previously saved level; If no one is seated within 15 minutes, the feature will stay off.

## Seat Heating

Heating is available for both the front and rear seats and is set to **off** by default. Enter the Comfort page from the bottom of the center display, and tap **Seats > Heating** to turn on heating for the corresponding seat and select the heating level. Seat heating operates at three levels, and will reach the preset level within 10 minutes and then maintain the same temperature.

Switch to the Seat Comfort page on the rear display to control the heating for the rear seats.

### Note

- With this feature on, the current level will be saved and the feature will turn off when the passenger leaves the seat for over 30 seconds;
- If someone is seated within 15 minutes after the passenger leaves, the feature will resume the previously saved level; If no one is seated within 15 minutes, the feature will stay off;
- Individuals with limited pain perception due to illness, ages, or other conditions should use the temperature control system and seat heating carefully to avoid potential low-temperature burns due to prolonged use.

## Seat Ventilation

Ventilation is available for front seats. Enter the Comfort page from the bottom of the center display, and tap **Seats >Ventilation** to turn on ventilation for the corresponding seat and select the ventilation level. Seat ventilation operates at three levels.

### Note

- With this feature on, the current level will be saved and the feature will turn off when the passenger leaves the seat for over 30 seconds;
- If someone is seated within 15 minutes after the passenger leaves, the feature will resume the previously saved level; If no one is seated within 15 minutes, the feature will stay off.

## Seat Relaxation

Lumbar relaxation is available for both the front and rear seats. Enter the Comfort page from the bottom of the center display, and tap **Seats > Relaxation** to select the desired relaxation mode (Mode 1, Mode 2, or Mode 3) for the rear seats.

- Mode 1: upper back massage
- Mode 2: lumbar massage
- Mode 3: cyclical massage from the upper back to the waist

Switch to the Seat Comfort page on the rear display to control the relaxation mode of the rear seats.

Once turned on, each mode lasts for 20 minutes and then stops automatically.

### Note

- With this feature on, the current level will be saved and the feature will turn off when the passenger leaves the seat for over 30 seconds;
- If someone is seated within 15 minutes after the passenger leaves, the feature will resume the previously saved level; If no one is seated within 15 minutes, the feature will stay off.

## Front Storage Space

The vehicle comes with a variety of convenient storage areas.

### **Warning**

Never place flammable and combustible objects or liquids with a high risk of splashing in the storage area. Always close the cover after placing objects in the storage area.

### ***Door Side Storage***

A storage area is provided under each door for beverages or objects. It is also equipped with a storage light to illuminate the corresponding door in the dark or when the position lights are on.



### ***Card Holders***

Each sun visor has a card holder for you to store cards such as name cards or toll cards.



### ***Cup Holders***

Your vehicle has two cup holders in the center console.



### **Warning**

- Do not put any hot beverages in an open container. A spill can increase the risk of injury.
- Do not place any fragile items, or they may cause injury when broken.

### ***Center Console Storage Area***

The open storage area under the center console can be used for temporary storage of non-critical items. A 12V power supply is provided in the rear of this area for passengers using electronic devices.

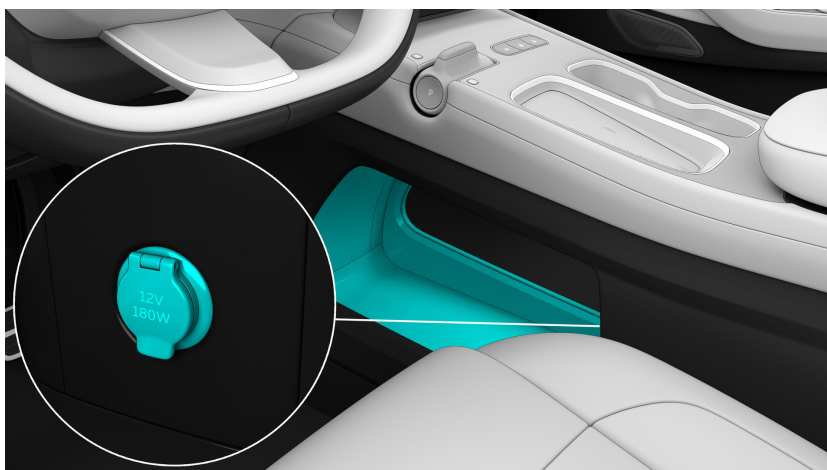



## Rear Storage Space

### ***Rear Door Side Storage***

The vehicle also provides convenient storage for the rear seats. A storage area is provided beside each door for beverages or objects. It is also equipped with a storage light to illuminate the corresponding door in the dark or when the position lights are on.



Garment hooks can be used to hang clothing.

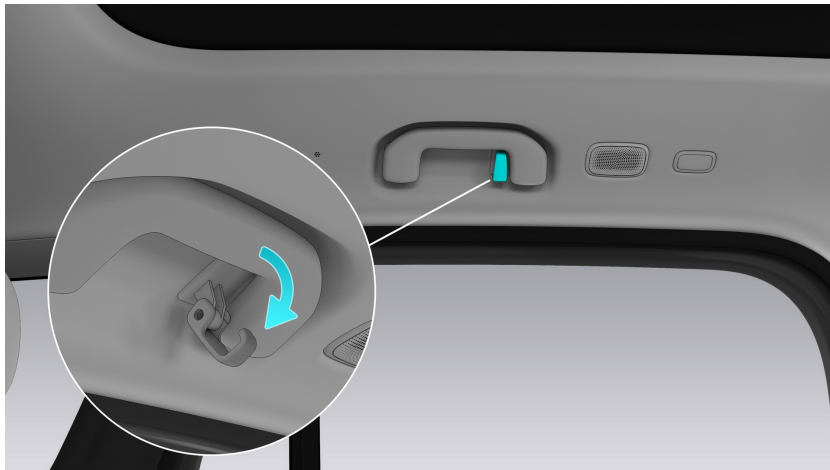



### **Warning**

Never place flammable and combustible objects or liquids with a high risk of splashing in the storage area. Always close the cover after placing objects in the storage area.

### ***Rear Row Center Armrest***

When the middle rear seat is not seated, pull down the center armrest stowed in the seat back to access the cup holders and storage area.

USB Type C ports in the storage area can be used for mobile device charging.





### Warning

- Never place flammable and combustible objects or liquids with a high risk of splashing in the storage area. Always close the cover after placing objects in the storage area.
- Do not place any heavy, sharp, or fragile objects on the armrest when driving. In case of collision, sudden acceleration, or deceleration, these objects may fly out, adding to the risk of injury.

## Center Storage Box

### ***Storage Box Mode***

By default, the center storage box is in the Storage Box Mode. In this mode, the center storage box is not locked, and the cover can be opened by pressing the button on either side of the center armrest:

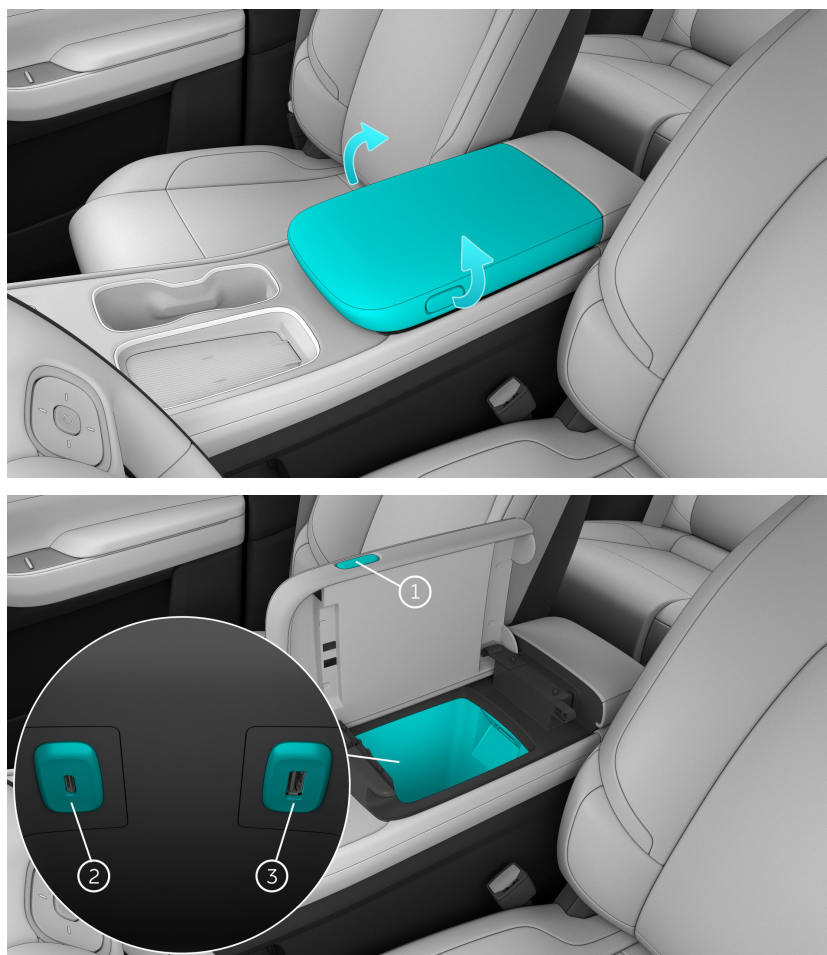

1. **Storage Box Button**  
Press the button (there is one button on the left and one on the right) and lift the cover to store items such as mobile phones, paper towels, etc.
2. **Storage Box USB Type C Port (60W)**  
High-speed interface for charging mobile devices. Data transfer is not supported.
3. **Storage Box USB Type A Port (7.5W)**  
Normal speed interface for data transmission, such as connecting USB media audio sources, exporting DVR videos, or connecting microphones. It can also be used to charge mobile devices.

### ***Safe Box Mode***

Swipe right on the home page of the center display to enter the Quick Settings page, and tap **Safe Box**. When Safe Box is enabled for the first time, a window for setting the password will pop up. After the password is confirmed, the Safe Box mode will be set.

At this time, to open the center storage box, you need to enter the password on the center display, and then open the cover by pressing the button on either side of the center armrest.

### ***Mode Switch***

You can switch between the two modes of the center storage box. Enter Settings from the bottom of the center display, and tap **Safety > Armrest Box** to switch between the two modes.

Storage Box mode > Safe Box mode:

- The Safe Box page is added.
- Set the password.

Safe Box mode > Storage Box mode:

- A risk warning shows.
- The Safe Box settings page disappears (is grayed out).

## Trunk

You can store your objects and luggage in the trunk.

The trunk has two compartments: a storage area above the trunk floor and a storage area under the trunk floor. You can also fold down the rear seats to expand storage space.

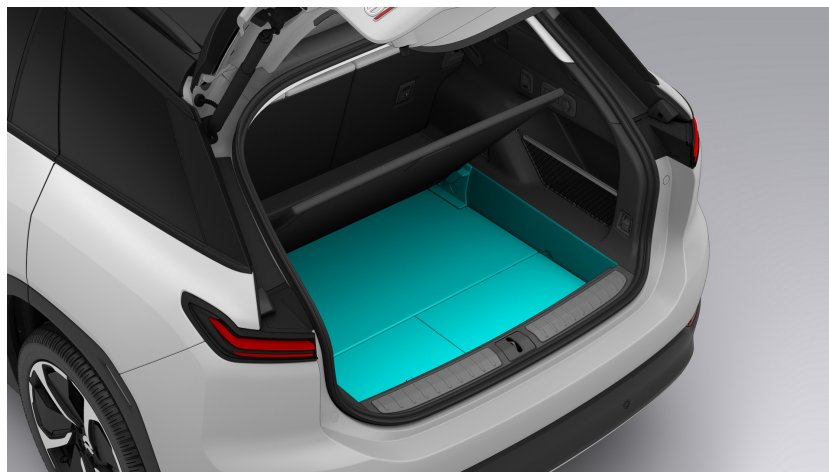

### Caution

When storing liquids in the vehicle, ensure that the container is sealed. Spills or leakages may damage the vehicle. If a spill or leakage occurs, please clean up the liquid as soon as possible.

### ***Load Anchoring Eyelets***

The load anchoring eyelets are used to attach a net or ropes to secure the cargo in the trunk. There are four eyelets in the trunk, with two on each side.

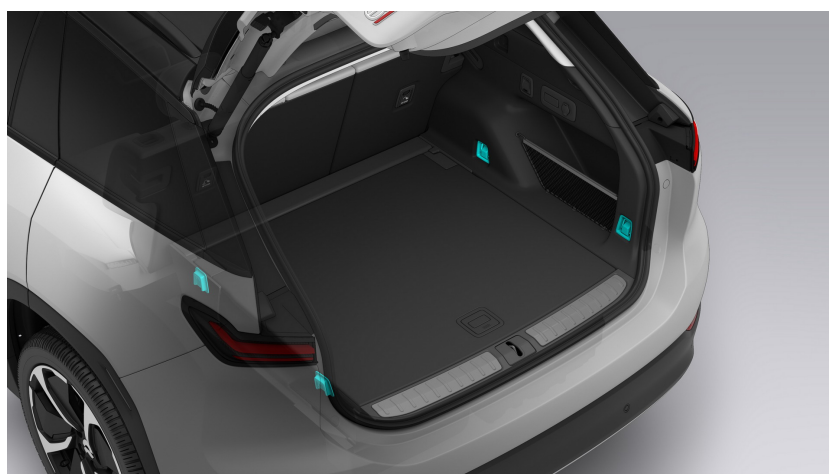

**Note**

The load capacity of a load anchoring eyelet is approximately 450 kg.

**Caution**

- Objects that are not secured or improperly secured may slide around, turn over or be thrown around in the cabin, which may result in injury to occupants. Sudden braking or turns may increase the risk of injury.
- Ensure that all objects are properly stored in the vehicle to avoid them being thrown around. Ensure that all objects are securely fastened before driving to avoid objects sliding around or turning over. Ensure that large or heavy objects are properly secured with belts or straps.

***12V Trunk Power Socket***

A 12V power socket is located on the right side of the trunk and can supply power to accessories as necessary.



## Easy Loading

You can lower the vehicle's ride height to make cargo loading/unloading easier.

Go to Settings from the bottom of the center display, and tap **Driving > Easy Loading** to enable the feature.

### Caution

- The ride height cannot be lowered further if it is already set to Very Low.
- The ride height can only be lowered to Very Low when you are driving below five km/h.

### Caution

Before enabling the feature, ensure that the area underneath your vehicle is clear of people, animals, or any objects. Failure to do so may result in injury or damage to the vehicle or other objects.



## Steering Wheel Adjustment



To adjust the position of the side mirrors, Enter Settings from the bottom of the center display, tap **Position Adjustment > Steering Wheel Adjustment > Start**, adjust the position with the buttons on the right side of the steering wheel, and tap **End** after the adjustment is completed; or swipe right on the home page on the center display to enter the Quick Settings page, and tap **Steering Wheel Adjustment > Start**.

**Adjust the steering wheel position with the right buttons on the steering wheel:**

Use the Up button to move the steering wheel up

Use the Down button to move the steering wheel down

Use the Left button to move the steering wheel away from the driver

Use the Right button to move the steering wheel closer to the driver

Press to move to the next position

Press and hold to move continuously

### Note

When the pop-up window is manually closed by the driver or passively closed due to factors such as conflicts, the right steering wheel controls will exit the steering wheel adjustment mode and resumes regular controls instead, such as answering phone calls, and increasing/decreasing volume.

**Warning**

- Do not adjust the steering wheel position while driving. Doing so may result in an accident.
- An improper steering wheel position or seating position may result in injury. Make sure your chest is at least 25 centimeters from the steering wheel.

## Right Buttons on the Steering Wheel



### ***Steering Wheel Adjustment***

Enter Settings from the bottom of the center display, and tap **Position Adjustment > Steering Wheel Adjustment > Start** to adjust the position with the right buttons on the steering wheel. See **Steering Wheel Adjustment**.

>

### ***Right Side Mirror Adjustment***

Enter Settings from the bottom of the center display, tap **Position Adjustment > Side Mirror Adjustment > Start** to adjust the position with the right buttons on the steering wheel. See **Side Mirror Adjustment**.

### ***Volume Adjustment***

In scenarios such as answering phone calls, talking to NOMI, and playing media, press the Up and Down buttons to adjust the volume, and press and hold the Down button to mute.

In other scenarios where there is no need to adjust the volume, there will be no response when you press and hold the Up button, but you can press and hold the Down button to mute.

When muted, press the Up button to unmute.

### ***Triggering Custom Feature***

Press and hold the right Middle button on the steering wheel to trigger your custom feature, which is set to NOMI by default and can be changed to a custom feature on the Settings page.

***Real-Time Control During Tasks***

When an incoming call reminder is displayed, you can press the left or right button to answer or reject the call and the middle button to confirm.

***Menu Change***

You can enter Change Mode by pressing and holding the left or right button, and press the left and right buttons in Change Mode to change the order of menu items.

If you press the middle button or do not operate the left and right buttons for 3 seconds, the current menu will be automatically selected, and Change Mode will be exited.

***Controls Within the Menu***

When the instrument panel displays the Media/Third-Party Software, Estimated Range, Range, and Consumption menu, you can use the left, middle, and right buttons on the right side of the steering wheel for global control of media/third-party software.

When the Media/Third-Party Software menu shows Media, press the left button to play the previous song, press the right button to play the next song, and press the middle button to play/pause.

When the Media/Third-Party Software menu shows Karaoke, press the left button to repeat, press the right button to play the next song, and press the middle button to play/pause.

When the instrument panel shows the Team Trip menu, press the middle button to record/send.

## Left Buttons on the Steering Wheel



### ***Left Side Mirror Adjustment***

Enter Settings from the bottom of the center display, tap **Position Adjustment > Side Mirror Adjustment > Start** to adjust the position with the left buttons on the steering wheel. See **Side Mirror Adjustment**.

### ***Driver Assist Adjustment***

Middle button: Activate or deactivate Driver Assist

Up button: Increase the cruise speed

Down button: Reduce the cruise speed

Right button: Increase the following distance

Left button: Reduce the following distance

Press the Up or Down button to change the cruise speed by +/-5 km/h; press and hold the Up or Down button to continuously change the cruise speed by +/-1 km/h.

Press the Left or Right button to change the following distance by -/+ 1 level; the minimum following distance is Level 1, and the maximum following distance is Level 5.

## Steering Wheel Heating

Turn on steering wheel heating in cold weather to enjoy a comfortable driving experience. To turn it on, go to the Comfort page from the control bar at the bottom of the center display and tap **Seats > Heating > Steering Wheel Heating**. The steering wheel will gradually warm up to a comfortable temperature within 10 minutes and then stays at that temperature.

## Steering Wheel Dual-Button Restart



If the display of the center display is stuck, unresponsive, or otherwise abnormal, rapidly restart the vehicle system to solve the problems.

### How to Perform a Dual-Button Restart:

1. Turn on the hazard warning lights;
2. Park the vehicle in a safe place, and shift to PARK;
3. Press and hold the left Right key and the right Down key on the steering wheel simultaneously for about 8 seconds;
4. Wait for about 30 seconds. All screens will light up again, and the system will resume operation.

If the problem persists, contact NIO immediately.

### Caution

- The vehicle must be in PARK to use Dual-Button Restart. Please ensure that the vehicle is parked in a safe area;
- It is strictly forbidden to perform Dual-Button Restart while the vehicle is moving;
- Keep the hazard warning light on while the vehicle is in the system restart process;
- Do not perform Dual-Button Restart when the vehicle software is being upgraded;
- During the restart process, the vehicle status display, safety warning, surround view image, map interface, and other information cannot be seen;

- If the screen fails to resume normal operation after Dual-Button Restart, you can try to lock the vehicle and put the vehicle to sleep. If the problem persists, please contact NIO.



## USB Ports

There are four USB ports available inside the vehicle, including one Type A (7.5W) port and three Type C (60W) ports.

Positions:

- Center storage box: one Type A (7.5W) port and one Type C (60W) port.
- Rear display: one Type C (60W) port.
- Rear center armrest: one Type C (60W) port.

## 12V Power Outlets

There are two 12V power outlets available inside the vehicle.

Positions:

- Behind the center console storage area
- On the right side of the tailgate

## Front and Rear Windshield Wipers

Front wipers can clean the front windshield. You can set the front wipers to different modes by toggling the lever on the right of the steering wheel.



Icon	Name	Function	Operation
1x	Single wipe	Front wipers wipe once	Toggle down the lever once
○	Off	Front wipers are turned off	Toggle the lever to this option
--	Intermittent wipers	Front wipers wipe intermittently	Toggle the lever up to this option
-	Consecutive wipers	Front wipers wipe continuously at a low speed	Toggle the lever up to this option
≡		Front wipers wipe continuously at a high speed	Keep toggling the lever up to this option



When Intermittent Wipes is enabled, you can adjust the frequency with the speed switch on the lever. Roll up the switch for a higher frequency and down for a lower frequency.

### **Warning**

In winter, ensure that the wiper blades are not frozen and the ice or snow in front of the windshield has been cleared before turning on the wipers.

### **Warning**

Be sure to use sufficient washer fluid to keep the windshield wet when wiping the windshield.

### ***Auto Front Wiper***



Press the Auto Wiper button  on the end of the right lever to enable the auto wiper feature. Press this button again or toggle the lever up and down to disable the auto wiper feature.

**Auto Rear Wiper**

Go to Settings from the bottom of the center display, and tap **Driving > Auto Rear Wiper** to enable the feature.

**Note**

To avoid damage to the wipers, ensure that the auto wiper feature is disabled when entering an automatic car wash machine.

**Cleaning the Front Windshield with Wipers**

Lift the lever on the right side of the steering wheel towards the driver's face, and select . The nozzles on the wiper arms will spray washer fluid, and the wipers will operate at low speed. Release the lever to stop spraying washer fluid.

Enter Settings from the bottom of the center display, and tap **Driving > Enhanced Cleansing** to enable this feature. Now the wipers will wipe one more time after spraying washer fluid. It is recommended to turn off this feature in winter in northern areas.

**Cleaning the Rear Windshield with Wipers**

Push the lever forward and select to enable the rear windshield wipers to work at a low speed.

Push the lever further forward and hold it, then select to spray washer fluid on the upper rear windshield with wipers working at a low speed. Release the lever to stop spraying and keep wiping. Pull the lever back to stop wiping.

**Caution**

To avoid damaging the washer pump, do not use the washer if the washer fluid is insufficient.

**Warning**

In bad weather conditions, ensure that the wiper blades are not frozen or attached to the windshield.

***Rear Windshield Auto Heating***

Enter Settings from the bottom of the center display, and tap **Driving** to enable rear windshield auto heating. When the front wipers are turned on on rainy days, rear windshield heating will be enabled automatically to help remove the water mist.

***Enabling/Disabling Wipers in Reverse***

When shifting into REVERSE with the front wipers on, the rear wiper will be turned on automatically. When shifting out of REVERSE, the rear wiper will be turned off.

When Auto Rear Wiper is enabled and the front wipers are turned on, the rear wiper operates automatically when reversing.

## Side Mirror Adjustment



Enter Settings from the bottom of the center display, tap **Position Adjustment > Side Mirror Adjustment > Start**, adjust the position with the buttons on the steering wheel, and tap **End** after the adjustment is completed; or swipe right from the left side of the home page on the center display to enter the Quick Settings page, and tap **Side Mirror Adjustment > Start**.

The left buttons on the steering wheel are used to adjust the left side mirror, and the right buttons on the steering wheel are used to adjust the right side mirror.

### Adjustment method:

Use Up and Down buttons to flip side mirrors up and down

Use Left and Right buttons to flip side mirrors left and right

Press to flip to the next position; press and hold to flip continuously

### Warning

Do not adjust the side mirrors while driving. Doing so may result in an accident.

## Side Mirror Folding

To set the side mirror auto-fold feature, enter Settings from the bottom of the center display, and tap **Driving > Auto Fold On Lock**.

After the vehicle is locked from the outside, the side mirrors will fold automatically. The next time the driver is seated in the driver seat (with the driver door closed and the brake pedal pressed), the side mirrors will unfold automatically.

If the vehicle is passing through a narrow road at a low speed (less than 40 km/h), you can manually fold the side mirrors by tapping **Driving > Side Mirror Folding** on the Settings page, and the side mirrors will automatically unfold when the vehicle speed exceeds 40 km/h.

In order to see the road clearly when reversing, you can turn on the **Auto-Tilt In Reverse** feature.



## Side Mirror Heating

The side mirrors are equipped with a heating feature to quickly dry rain or snow on them.

You can enter Settings from the bottom of the center display, and tap **Driving > Side Mirror Heating** to manually turn on the side mirror heating feature.

The side mirror heating automatically turns off after 60 minutes. You can also manually turn it off from the center display.

### ***Side Mirror Auto Heating***

Enter Settings from the bottom of the center display, and tap **Driving** to enable side mirror auto heating. When the front wipers are turned on on rainy days, side mirror auto heating will be enabled automatically to help remove the water mist.

## Rearview Mirror and Side Mirror Auto-Dimming

Enter Settings from the bottom of the center display, and tap **Driving > Rearview Mirror and Side Mirror Auto-Dimming** to enable the rearview mirror and side mirror auto-dimming feature.

The rearview mirror and side mirror auto-dimming feature can reduce the glare of headlights from vehicles behind you to reduce safety risks.

### Note



The auto-dimming feature is not available when the vehicle is in REVERSE with the front reading lights on.

## Front Climate Control

### **Climate Control Bar**

You can adjust the temperature and air distribution inside the vehicle from the climate control bar at the bottom of the center display.



1. Home  
Tap to return to the home page.
2. Settings  
Tap to enter Settings.
3. Air circulation  
Displays the current air circulation mode. Tap to switch between Recirculation Mode , Auto Circulation Mode , and Fresh Air Mode .  
With Auto Circulation Mode on, when the outside air is heavily polluted, the vehicle automatically switches from Fresh Air Mode to Recirculation Mode to ensure optimal cabin air quality.
4. Driver-side temperature  
Displays the target temperature on the driver's side. Tap to access the climate control panel.  
Swipe left or right to adjust the driver-side temperature between 15–31 degrees Celsius.  
Tap the arrow to adjust the temperature in 0.5-degree increments/decrements.  
Tap Sync to apply the driver-side temperature settings to the front passenger seat and rear seats. To stop temperature sync, manually adjust the temperature of the front passenger or rear seats on the center display.
5. Climate and fan speed adjustment  
Displays the climate on/off status. Tap to expand or collapse the climate control panel.  
Press and slide to adjust the front fan speed between Level 0-8. At Level 0, the climate control of the whole vehicle will be turned off.
6. Passenger side temperature  
Displays the target temperature on the passenger side. Tap to access the climate control panel.

Swipe left or right to adjust the passenger side temperature between 15-31 degrees Celsius.

Tap the arrow to adjust the temperature in 0.5-degree increments/decrements.

7. Front windshield defrosting/defogging

When the front windshield defrosting/defogging feature is turned on, the Manual Mode (A/C) will be turned on simultaneously. The air distribution mode will be Air on Windshield, and the air circulation will be switched to Auto Circulation Mode.

When the outside of the front windshield becomes fogged, it is recommended to turn on the wipers and AUTO Mode of climate control. When the inside of the front windshield becomes fogged, it is recommended to turn on the front windshield defogging feature. After the fog is removed, turn on the AUTO Mode of climate control and enable Auto Defogging.

You can enter Settings from the bottom of the center display and tap **Cabin Comfort > Auto Defogging**. The front windshield defogging feature will be automatically turned on when the front windshield fogs up inside.

8. App center

Apps in the center display

9. Volume Adjustment

The default value of the volume is 50%. Tap the icon and slide left and right to adjust the volume.

Tap and hold to mute, and tap and hold it again to restore the volume before muted.

### ***Front Climate Control Panel***

When any interface is displayed on the current center display, to adjust the front and rear temperatures, tap the temperature or climate control icon in the climate bar to access the climate control panel.



1. Turning the front climate control on and off  
Tap the power button to turn the front climate control on.  
Tap a second time to turn the front climate control off. In this case, the rear climate control will also be turned off.
2. Manual Mode (A/C)  
Tap to turn on Manual Mode (A/C). In this case, you can manually adjust the fan speed and temperature for cooling or heating.  
If you turn it off, the vehicle switches to Fresh Air Mode.
3. Max Cooling Mode  
Tap to turn on the max setting for cooling. If Manual Mode (A/C) is also on, the vehicle will automatically switch to Recirculation Mode with the fan speed set to the highest level and air distribution set to Air on Face.  
Tap a second time to turn Max Cooling Mode off and restore the air conditioning to the previous settings.
4. Max Heating Mode  
Tap to turn on the max setting for heating. If Manual Mode (A/C) is also on, the vehicle will automatically switch to Recirculation Mode with the fan speed set to the highest level and air distribution set to Air on Feet.  
Tap a second time to turn Max Heating Mode off and restore the air conditioning to the previous settings.
5. Front windshield defrosting/defogging  
When the front windshield defrosting/defogging feature is turned on, the Manual Mode (A/C) will be turned on simultaneously. The air distribution mode will be Air on Windshield, and the air circulation will be switched to Auto Circulation Mode.

When the outside of the front windshield becomes fogged, it is recommended to turn on the wipers and AUTO Mode of climate control. When the inside of the front windshield becomes fogged, it is recommended to turn on the front windshield defogging feature. After the fog is removed, turn on the AUTO Mode of climate control and enable Auto Defogging.

You can enter Settings from the bottom of the center display, tap **Cabin Comfort > Auto Defogging**, and set the sensitivity. The front windshield defogging feature will be automatically turned on when the front windshield fogs up inside.

6. Rear windshield heating

Tap to warm up the rear windshield. This feature automatically turns off after 15 minutes.

7. Air Vent Mode

**Off:** The driver-side air vents are closed. You cannot turn off the four air vents in the front at the same time.

**Free:** The angle of the two driver-side air vents can be adjusted individually.

**Balanced:** The angle of the two driver-side air vents are symmetrical.

**Sweep:** The air vents sweep up and down, left and right.

8. Front fan speed

Tap the "+" or "-" icon to adjust the front fan speed. The front vents operate at eight speed levels.

9. AUTO







Tap to turn on AUTO Mode. This automatically adjusts the temperature, fan speed, air distribution, and air circulation of the front and rear seats according to the temperature you set.

Tap a second time to turn off AUTO Mode. The air conditioning status will remain unchanged.

10. Air distribution

Users can choose from seven air distribution modes: Air on Windshield, Air on Face, Air on Feet, Air on Face and Feet, Air on Feet and Windshield, Air on Face and Windshield, and Air on Windshield, Face and Feet.

Icon	Air distribution
	<p>Air on windshield</p> <p>If used together with a high fan speed, it will quickly defog and defrost the front windshield in cold and humid weather conditions.</p>

	<p>Air on face Heats or cools the front cabin.</p>
	<p>Air on feet Heats or cools the footwell areas.</p>
	<p>Air on face and feet Conditions the front cabin including the footwell areas to a comfortable temperature.</p>
	<p>Air on feet and windshield Defrosts the front windshield while heating or cooling the footwell areas.</p>
	<p>Air on face and windshield Defrosts the front windshield while heating or cooling the front cabin.</p>
	<p>Air on windshield, face, and feet Defrosts the front windshield while conditioning the front cabin including the footwell areas to a comfortable temperature.</p>

**Front Air Vent Adjustment**

The front air vents are located below the windshield and both on and underneath the instrument panel.





1. Front windshield vents
2. Face-level vents
3. Foot-level vents

The front air vents on the instrument panel can be adjusted as follows:

Press the air vent area on the center display and slide up and down to control the vertical angle, and slide left and right to control the horizontal angle.

In the Free mode, you can double-tap an air vent on the center display to close the corresponding air vent. But at least one air vent should remain open.

### ***Tips for Using Air Conditioning***

- Keep the grille clear of any obstructions (e.g. leaves, snow).
- If the vehicle is parked in extremely hot weather conditions, turn the air conditioning on and open the windows simultaneously to rapidly cool the cabin.



## Rear Climate Control

### ***Rear Climate Control Panel***

A climate control panel is available on the rear display for rear passengers to adjust the temperature and fan speed.

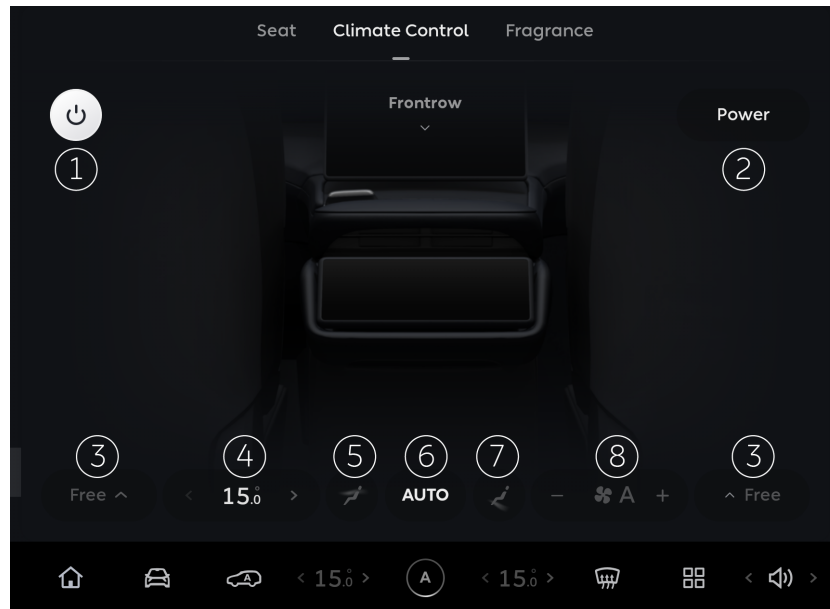

1. Turning the climate control on and off  
Tap to turn on or off the front and rear climate control.
2. Rear switch  
Tap to turn on or off the rear climate control.
3. Rear air vent modes  
Off: The rear air vents are closed. You cannot turn off both air vents in the rear at the same time.  
Free: The angle of the two rear air vents can be adjusted individually.  
Sweep: The rear air vents sweep up and down, left and right.
4. Rear temperature display  
Displays the target temperature in the rear. Tap to access the temperature control panel.  
Press the temperature value and slide left and right to adjust the temperature in a range of 15-31°C.
5. Air on face  
Heats or cools the rear cabin.
6. AUTO

Press the button to turn on AUTO Mode, where the temperature, fan speed, and air distribution of the rear cabin will be automatically adjusted according to the temperature you set.

Tap a second time to turn off AUTO Mode. The air conditioning status will remain unchanged.

7. Air on feet  
Heats or cools the footwell areas for rear passengers.
8. Rear fan speed  
Tap the "+" or "-" icon to adjust the rear fan speed. The rear vents operate at six speed levels.

### ***Rear Climate Control Panel***



The rear display provides rear passengers with rear climate control.

### ***Rear Air Vent Adjustment***

The rear air vents are located at the bottom of the rear control panel as well as under the driver and front passenger seats.



1. Rear face-level vents
2. Rear foot-level vents

Rear air vents can be adjusted as follows:

Press the air vent area on the center display or the rear display and slide up and down to control the vertical angle, and slide left and right to control the horizontal angle.

In the Free mode, you can double-tap an air vent on the screen to close the corresponding air vent. But at least one air vent should remain open.

## Air Purification

### ***Air Purification Modes***

You can view the current cabin air quality in the top right corner of the center display, and choose an air purification mode:

- **OFF:** Turn air purification off;
- **AUTO:** Allow the vehicle to automatically adjust the fan speed according to the concentration of PM2.5 in the cabin;
- **QUIET:** Purify the air in the cabin quietly at a low fan speed.

### ***Ionizer***

To further improve the air quality in the cabin through ionization, go to Settings from the bottom of the center display, and tap **Cabin Comfort > Ionizer**.

### ***A/C Odor Removal***

In hot weather, when the vehicle is in PARK and the air conditioning is operating, condensation may remain in the climate control system. Enter Settings from the bottom of the center display, and tap **Cabin Comfort > A/C Odor Removal**. When you leave and lock the vehicle, if residual water is detected in the climate control system, the blower will automatically turn on to the maximum speed to get rid of moisture in the evaporator and air duct, limiting the bacteria growth in the moist environment.

You can choose from two modes, **Standard** (the blower continues to operate for about three minutes) and **Strong** (the blower continues to operate for about twenty minutes).

This feature may consume some power in certain environments. Please plan your trip properly or turn it off as needed.

## Music

Tap Media on the home page and select your preferred radio or music streaming service:

- Choose "Tidal" to search and play your favorite music. You can sync music and add tracks or albums to Favorites.
- Insert a USB drive to play music from it.
- After connecting a mobile device to the vehicle via Bluetooth, you can choose Bluetooth Music to play music from the device.

To control media volume, enter Settings from the bottom left of the center display, and touch Sound. Tap Sound Mode to set the cabin's sound field performance. If necessary (i.e. when your child is sleeping in the rear seats), you can also turn on Rear Mute.

Dolby Atmos for Cars provides you with a well-tuned, balanced sound experience and optimal listening configuration optimized for the vehicle's interior environment, making the cabin an ideal listening space for immersive music experiences with more layered and richer sound than ever before. Manufactured under license from Dolby Laboratories. Dolby, Dolby Atmos, and the double-D symbol are registered trademarks of Dolby Laboratories, Inc. Confidential unpublished works. Copyright 2012-2021 Dolby Laboratories. All rights reserved.

## Navigation

To select a route to a location, visit Navigation on the center display. If you have already sent a route via the NIO app, the center display will automatically display the selected route after it is turned on.

Tap  to set navigation settings including route preference, voice navigation, and map display.

## Photos and Videos

### ***Photos***

In the vehicle, you can ask NOMI to help you take selfies. The photos or videos taken are stored in the **Photos** app on the center display, and can be exported via a USB cable.

## Phone

When your mobile phone's Bluetooth is successfully paired with your vehicle's Bluetooth, the on-board Bluetooth phone function can be used after your vehicle is authorized on your mobile phone to synchronize your mobile phone contacts and recent calls. You can see the phone page on the home page or on the application center in the central display.

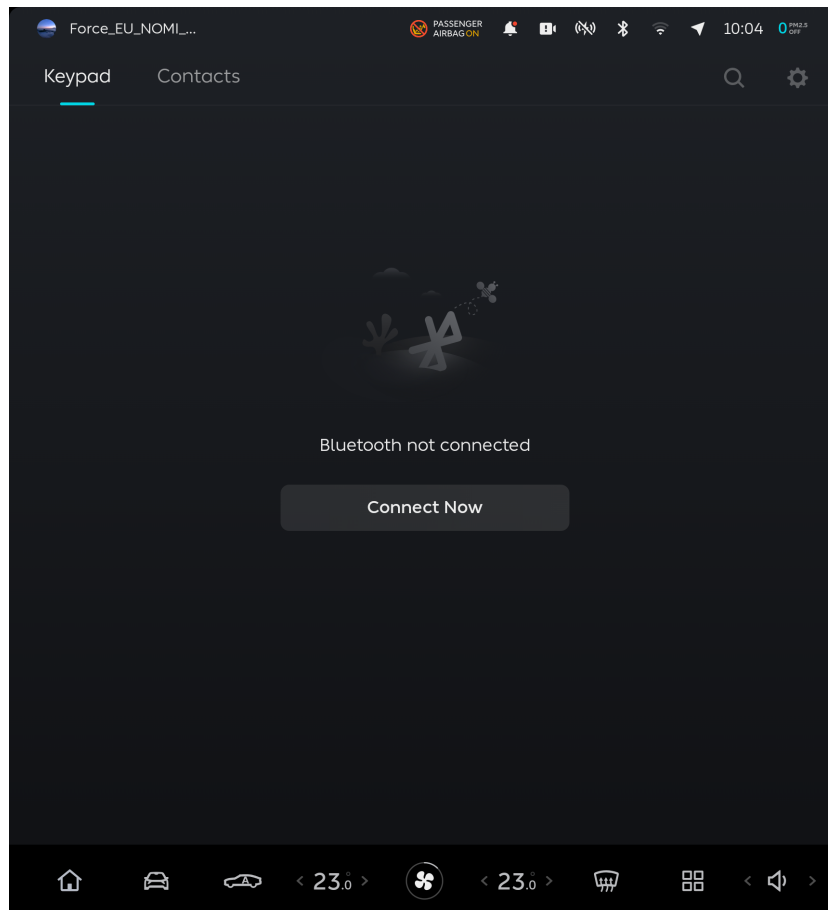

When your contacts and recent calls in your mobile phone are synchronized to your vehicle, you can choose a specific contact or recent call or enter a phone number directly to make a call. You can switch between private mode and hands-free mode during a call.

You can browse your recent calls, or switch to other Bluetooth phone devices or hide your recent calls in the dialing page.



## Connecting to Mobile Devices

You can connect the vehicle to a mobile device (e.g. phone, tablet) via Bluetooth or Hotspot, and sync your mobile device (e.g. phone contacts, music) to the vehicle on the center display for an optimal infotainment experience. The mobile device will be automatically synced to your vehicle the next time it is connected. You don't need to re-allow the connection.

To connect your mobile device via Bluetooth or Hotspot, tap the Bluetooth or Hotspot icon at the top of the center display:

1. Turn on Bluetooth or WLAN on your mobile device (e.g. phone, tablet).
2. Enter Settings from the bottom of the center display, and tap **Connect** to enable the Bluetooth or Hotspot feature.
3. Choose the mobile device you want to connect to on the center display to pair the device manually.

Alternatively, you can connect a mobile device via Bluetooth or Hotspot with one tap by placing it on the wireless charging pad and following the instruction below (this approach is only available for certain phones):

1. Turn on NFC, and Bluetooth or WLAN on your phone.
2. Place the phone on the wireless charging pad on the center console.



3. Enter Settings from the bottom of the center display, tap **Connect** to open the Bluetooth or Hotspot page, and choose "Connect via NFC on Phone".

**Note**

Do not remove your phone from the charging pad when it is connected to the vehicle via Bluetooth or Hotspot.

## Wireless Charging

You can charge a wireless charging device by placing it on the wireless charging pad on the center console.



Wireless charging is set to on by default. You can enter Settings from the bottom of the center display and tap **Connect > Wireless Charging** to disable the feature. The current setting is saved in the vehicle owner's account or the authorized user account. The current charging status is shown on the center display.

When the wireless charging pad is occupied by a mobile device connected via Bluetooth or NFC quick connect, charging will stop.

Under the following conditions, charging will stop, and the center display will display a status notification:

- Charging is complete.
- A fault occurs during charging. For example, the charging voltage might be too high or too low.

### Caution

- When wireless charging is enabled, any metal object (such as a key, coin or NFC card) placed on the wireless charging pad may affect its charging efficiency or even lead to a burn.
- When using wireless charging, do not place any metal objects between the phone and the charging plate, such as coins and cards with chips/battery. Do not use phone cases with metal materials, such as those that support magnetic charging (MagSafe).

- It is normal for the phone to become hot after being charged for a long period of time. Do not place a fully charged device on the charging pad. Doing so can cause overheating.
- Do not charge two or more devices wirelessly at the same time.
- The vent of the cooling fan is at the bottom of the wireless charging pad. Prevent small foreign objects and liquids from entering it.



## NOMI

NOMI, NIO's in-vehicle AI assistant, is located on the upper instrument panel. You and other occupants can directly communicate with NOMI and control certain features through voice commands. NOMI is an intimate companion for your journey.

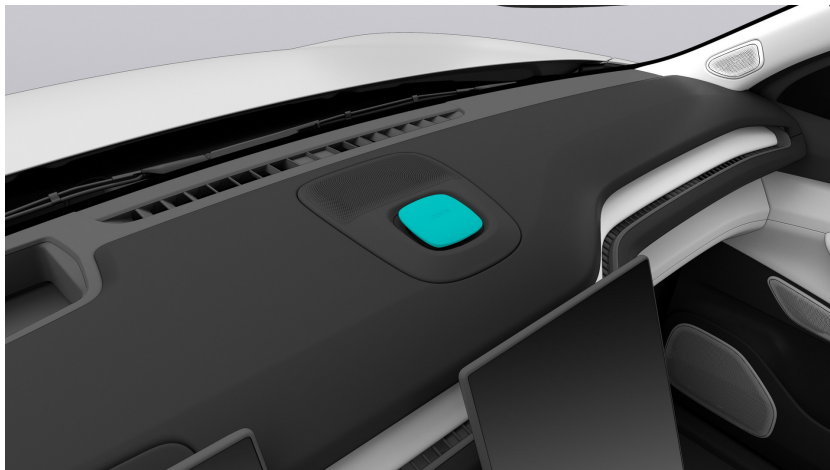
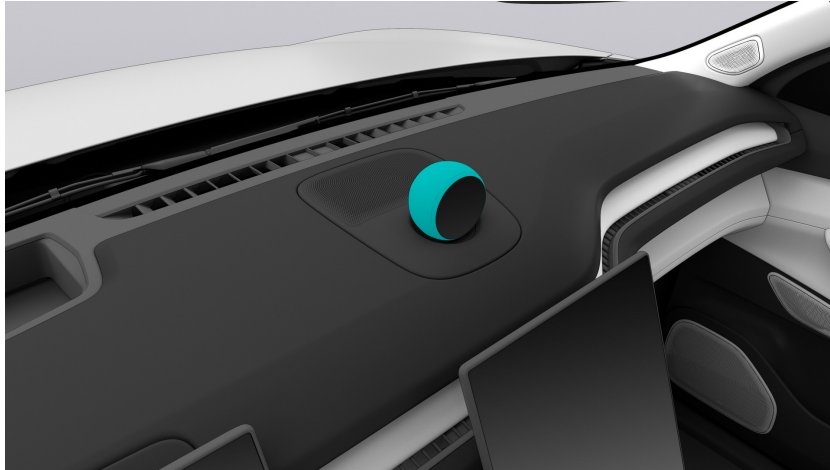

When you enter the vehicle (with the driver door closed or the brake pedal pressed once), NOMI will greet you warmly. To control certain features via NOMI, say the wake word (which is "Hey, NOMI" by default) or press the voice command button on the right side of the steering wheel to wake NOMI. After NOMI responds to your call (e.g. by saying "I'm here"), you can give a command. When a conversation ends or a task is completed, NOMI automatically switches to Standby Mode. You can wake NOMI anytime you want.

To customize a wake word, Enter Settings from the bottom of the center display, and tap **NOMI > Set Wake Word**. It will then be saved to your account and updated automatically the next time you are seated. You need to add "Hey" before a wake

word with two Chinese characters; if the customized wake word consists of three to six Chinese characters, you can wake NOMI up by simply saying the word.

You can turn on the continued conversation for NOMI by going to Settings from the control bar at the bottom of the center display, and tapping **NOMI > Continued Conversation**. With it on, when NOMI is waked up by an occupant, the conversation can be continued in 20 seconds without using the wake word. If another occupant wants to communicate with NOMI, the occupant can reactivate NOMI. Tap **Immersive Voice Conversation** to hide the transcription of your and NOMI's speech.

Category	Feature (more easter eggs coming soon)	Recommended commands
Basic features	Wake NOMI up	Hey, NOMI.
	Introduce NOMI	What are you capable of?
	Offer a suggestion	I have a suggestion. I have some feedback for you.
	Dismiss NOMI	Cancel/exit/goodbye.
	Do Not Disturb Mode (When turned on, NOMI will not speak spontaneously but will still respond to your requests)	Do Not Disturb on. Don't disturb me. Do Not Disturb off. Don't oversleep. Wake up.
Media	Volume Adjustment	Set music/media volume to maximum. Set volume to 60%/minimum/50%. Mute.
	Play music	Play a song for me. Play XXX. Next track. Loop single song/Repeat playlist/ Shuffle play. Add this song to Favorites. I don't want to listen to XX's songs. Play a song from USB.
Phone	Make a Phone Call	Call XXX.
	Answer a call	Answer/decline.

Entertainment	Tell a joke	Tell me a joke.
	Selfie	Take a photo. Take another photo.
Navigation	Navigate to a place	I need navigation. I need to charge. I'm hungry. I want to eat hot pot.
	Plan route	Number one. Take me to the nearest. Reroute.
	Save address or add to Favorites	Edit home address. Save current location.
	Change map settings	Zoom in on map. Switch to 2D map. Head up.
	View or end navigation	How much longer to work? How's the traffic? End navigation. Stop navigation.
Climate Control	Adjust temperature	Set (driver/front passenger/rear) temperature to 26 degrees Celsius.
	Adjust fan speed	Lower the driver-side fan speed a bit. Set fan speed to highest.
	Turn climate control on/off	Turn (rear) climate control on. Turn AUTO Mode on.
	Adjust air distribution and air circulation	Air on face, air on feet, air on windshield, air on feet and windshield, air on face and feet. (Turn on/off) front/rear defrosting. Turn Recirculation Mode on.
	Air Purification	Turn on air purification. What's the PM2.5 level inside? Silence the air purifier.
Windows	Window Control	Open/close (driver, front passenger, left rear, right rear, all) window(s). Open the windows fully.

		Open the window by 20%. Open rear windows a crack.
Seats	Seat Ventilation	Turn on (driver/front passenger) seat ventilation. Turn down seat ventilation a bit.
	Seat Heating	Turn on (driver/front passenger/left rear/right rear) seat heating. Turn up the seat heating a bit.
	Seat Massage	Turn on (driver/front passenger) seat massage. Increase the intensity a bit. Set seat massage to level 3.
Steering Wheel	Steering Wheel Heating	Turn on steering wheel heating.
Lights	Ambient lighting	Turn on ambient lighting. Change the ambient lighting color.
Controls on Center Display	Adjust screen brightness	Dim the center display a bit. Raise the brightness to the maximum.
	Bluetooth/WLAN/Hotspot	Turn on/off (Bluetooth/WLAN/Hotspot).
	Applications	Return to desktop. Go to Media/Phone/Navigation/Music/Weather/Settings.

**Warning**

- Keep NOMI and its base away from any liquids, acid or alkaline solvents, dirt, fibers, or magnetic materials.
- Do not disassemble or repair NOMI and its base.
- Do not push, pull or twist NOMI, or obstruct its movement.
- Do not attempt to remove NOMI and its base.



## Comfort Features

When the vehicle is in PARK (without being locked from the outside) and the driver's seat is unoccupied, occupants can still enter the vehicle and access certain comfort features. The feature will automatically turn off after 10 hours without any operations. To continue using a comfort feature, open any door, press the brake pedal, or sit in the driver's seat with the driver's door closed.

Comfort features mainly include:

- Driver's/passenger seat adjustment
- Steering Wheel Adjustment
- Wireless Charging
- Front A/C Control
- Seat massage, heating and ventilation
- Steering Wheel Heating
- Window Control
- Reading lights and ambient lighting
- Entertainment and navigation
- NOMI

## Intelligent Fragrance System

A fragrance system is provided for you and your family. You can select the desired scent to enjoy a refreshing and pleasant experience while driving.

A variety of fragrances are offered, including Solar, Adventure, and Haven. You insert your favorite fragrance cartridge into the fragrance holder located under the center console and can replace the cartridge according to your preference.

To insert and replace the fragrance cartridges:

1. Remove the cover of the fragrance cartridge, insert the cartridge facing up in the holder, and then press the bottom of the cartridge.

### Caution

Do not rotate the fragrance cartridge when inserting it.

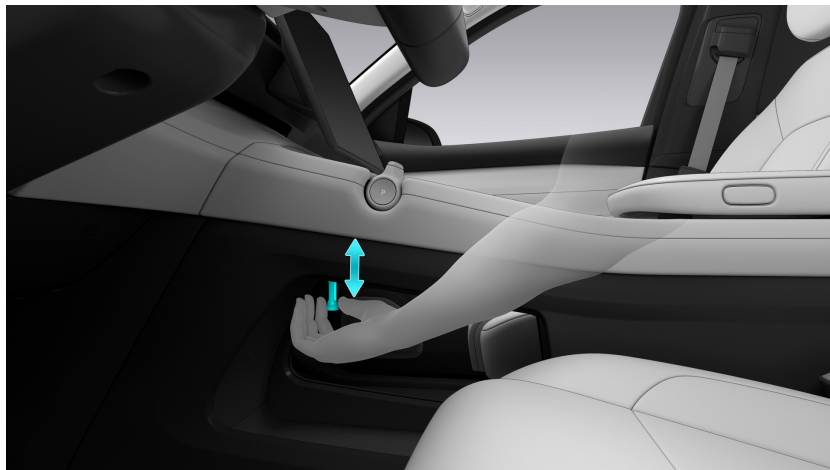

2. The cartridge will then be held in place by a magnet placed inside the holder.
3. When the fragrance cartridge is in place, the vehicle will notify you that the fragrance system is available and indicate the exact scent of each cartridge on the center display.
4. To replace the fragrance cartridge, hold the bottom of the cartridge with your fingers and pull it out slowly.

To turn the fragrance system on or off, control the intensity of a fragrance, or select a different scent, insert the fragrance cartridge, and swipe right on the home page to visit Quick Access and select **Fragrance**.

**Warning**

- Keep the fragrance cartridge out of the reach of children to prevent them from swallowing it accidentally, as this may be detrimental to their health.
- Do not allow your child to insert their finger into the fragrance holder. Doing so may result in injury.
- To ensure your safety, do not insert or replace the fragrance cartridge while driving.
- If you or any passenger feels discomfort, disable the fragrance system immediately.

**Caution**

- Please check the expiration date before inserting the fragrance cartridge. The fragrance has a shelf life of one year if the bottle remains unopened; after the bottle is opened, the fragrance can last three months. Stop using the fragrance and replace it after it expires.
- Some fragrances (e.g. Wild) have a stimulating effect. Please use it only when needed.
- When replacing the fragrance cartridge, keep your hands clean to ensure the fragrance system can function normally after it is replaced.
- A magnet is placed in each fragrance holder. Keep your smart phone, tablet and other electronic devices away from the holder to avoid any interference between electronic devices and the fragrance system.
- Chemical reactions may occur between the fragrance and organic substances. Keep the ceramic fragrance stuck in the fragrance cartridge and away from all plastic parts.

**Note**

- The experience with the fragrance system may vary depending to the cabin temperature, fan speed, and user's physical condition.
- Only purchase genuine ceramic fragrance sticks and avoid damaging the fragrance cartridge to ensure its quality.
- If the fragrance cartridge cannot be identified after it is inserted, please try again.

## Tide



Tide is a physical and psychological health app that helps you sleep, meditate, relax, and stay focused. Inspired by travels, nature and meditation, Tide provides a wealth of audio resources such as sounds of nature and meditation exercises to help you escape from the fast-paced world for a quiet space of peace, where you can meditate for a while to relax your mind and sleep better with less anxiety and stress while staying focused and calm.

Tide offers three modes, namely Nap, Meditation, and Breathing.

### ***Nap Mode***

You and your family can fall asleep to the sounds of nature in the vehicle and wake up to a soft alarm to embrace a beautiful world.

You or your authorized users can enter the application launcher to open the **Tide > Nap** page where sound scenarios and alarm time for the nap can be set and memorized for the specific account.

- Nap by Time: You can set a nap countdown to wake you up at the set time. You can also choose to continue or end the nap upon the alarm.
- Nap by Charge: If the vehicle is in the DC charging process, you can set a battery level within the charging limit to have a nap until the set level is reached.
-  More settings are provided, including volumes and timed playback of sleep aid sounds, alarm clock sounds and volumes, and seat position restoration switch upon the end of nap.
-  Set sleep aid sound scenarios.

After the vehicle enters the Nap Mode, the in-vehicle lighting will be turned off, with windows and doors closed and locked, the climate control will be automatically set to the temperature comfortable for a nap, and the air purifier will be automatically turned on. If you sit in a front seat, the seat will automatically move to the relax position (if set previously) or the default position. NOMI will enter the Do Not Disturb Mode to create a relaxing atmosphere for you. After the nap ends, the vehicle will restore the settings before the nap.

## Caution

- Before entering the Nap Mode, make sure the vehicle is in PARK and not in the power swap mode.
- Close all the doors and the liftgate before starting the Nap Mode to ensure safety.
- A fault with the climate control system may compromise the comfort during the nap.
- When the front seats are moving backward at the beginning of the nap, pay attention to the space for occupants on rear seats. If the long track engages for the front passenger seat, the front passenger seat will not automatically move after the nap starts.
- If the vehicle is not being charged, make sure that its remaining range is not less than 60 km. The time alarm will be triggered automatically when the remaining range is less than 30 km, and the charging alarm will be triggered automatically when the charging connector is disconnected or the charging runs into a fault, to remind you to check the battery level.
- The vehicle will automatically exit the Nap Mode under certain circumstances, for example, when the vehicle is not in PARK, the battery has a risk of ignition, a software update is in progress, the vehicle is in the power swap mode, the vehicle is locked for sleep, the climate control is faulty, and the account is switched. In this case, the seats cannot be automatically restored to the positions before the nap.

## ***Meditation Mode***

The Meditation Mode provides an immersive experience to give your brain break, so that you can feel your inner self and your surroundings and reduce your physical and mental exhaustion.

You or your authorized users can enter the application launcher to open the **Tide > Meditation** page where sound scenarios and sound volumes for the meditation can be set and memorized for the specific account.

After the vehicle enters the Meditation Mode, the in-vehicle lighting will be turned off, with windows and doors closed and locked, the climate control will be automatically set to the temperature comfortable for meditation, and the air purifier will be automatically turned on. NOMI will enter the Do Not Disturb Mode to create an immersive and quiet atmosphere for you. After the meditation ends, the vehicle will restore the settings before the meditation.

**Caution**

- Make sure the vehicle is in PARK and not in the Power Swap Mode.
- Close all the doors and the liftgate before starting the Meditation Mode to ensure safety.
- If the vehicle is not being charged, make sure that its remaining range is not less than 30 km.
- The vehicle will automatically exit the current mode under certain circumstances, for example, when the vehicle is not in PARK, the battery has a risk of ignition, a software update is in progress, the vehicle is in the power swap mode, the vehicle is locked for sleep, and the account is switched.

***Breathing Mode***

The Breathing Mode helps you learn how to breathe properly, calm yourself down, and relieve stress.

You or your authorized users can enter the application launcher to open the **Tide > Breathing** page where breathing scenarios and background sound scenarios and volumes can be set and memorized for the specific account.

**Caution**

- Make sure the vehicle is in PARK and not in the Power Swap Mode.
- Close all the doors and the liftgate before starting the Meditation Mode to ensure safety.
- If the vehicle is not being charged, make sure that its remaining range is not less than 30 km.
- The vehicle will automatically exit the current mode under certain circumstances, for example, when the vehicle is not in PARK, the battery has a risk of ignition, a software update is in progress, the vehicle is in the power swap mode, the vehicle is locked for sleep, and the account is switched.















## Quick Access

You can tap **Quick Access** in the application launcher on the center display to freely combine apps for customized scenarios, or enter the Square interface to enjoy a personalized and automated intelligent experience using the recommended Quick Access templates.

















Actions that support custom shortcuts include: time, media, weather, cabin comfort, driving, charge, doors, windows, seats, lighting, system settings and applications, and other common settings. You can also share custom scenarios with friends.















## Instrument Cluster Indicators

Please contact NIO immediately if any of the following indicators are not in their normal state.

Icon	Note
	Auto High Beams
	High beams
	Autohold
	Position lights
	Low beams
	Front fog lights
	Vehicle ready
	Left turn signal
	Right turn signal
	Rear fog lights
	Icy/Snowy road
	Pedestrian Warning Sound off
	Brake system fault
	Electronic Stability Control (ESC) on/ fault
	Low battery level



	Speed limit reminder or Speed Limit Mode fault
	Trailer connection status
	Smart headlights fault
	Electronic Stability Control (ESC) Off
	Advanced Driver Monitoring System (ADMS) fault/start self-test
	No face detected by Advanced Driver Monitoring System (ADMS)
	Lane Departure Warning (LDW) And Assist off
	Overspeed Warning off
	Limited power
	ABS fault
	Tire Pressure Monitoring System (TPMS) warning
	High voltage battery cutoff
	Autonomous Emergency Brake (AEB)/ Forward Collision Warning (FCW) off/ fault
	Hand-off warning
	Charging cable connected
	Electric Parking Brake (EPB)
	Advanced Driver Monitoring System (ADMS) status

	Powertrain fault
	Electric Parking Brake (EPB) fault
	Seat belt warning
	Airbag fault
	Driving motor fault
	12V battery charging fault
	High voltage battery fault
	High voltage battery overheat
	Trailer electrical connection fault
	Blind Spot Detection (BSD) and Lane Change Assist (LCA) fault
	Front Cross Traffic Alert (CTA-F)/Rear Cross Traffic Alert with Braking (RCTA-B) fault
	Driver Assist fault
	Speed limit fault
	Shiftless Advanced Parking Assist with Fusion (S-APA with Fusion) fault
	Lane Departure Warning And Assist (LDW) fault

## Controls on Center Display

### Controls on the Front Center Display

When you or an authorized user logs in, the center display can seamlessly access rich and customized content, such as music, navigation, radio, etc. You can also personalize and save your favorite content to your account. The vehicle will automatically load any saved content the next time you log in. When you switch between different accounts, the vehicle will display personalized content saved to the corresponding account.

You can access the desired features (e.g. media, navigation) from the home page. The following features are provided on the center display:

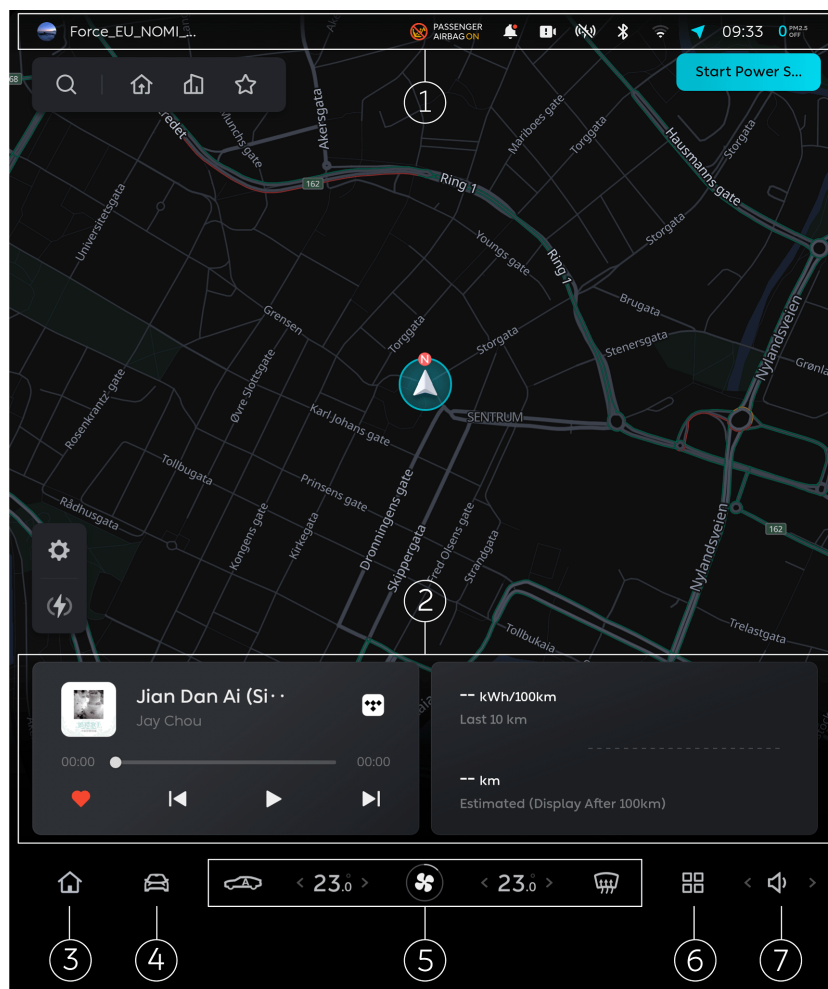

1. Info bar  
Displays alert messages, warning messages and warning icons, etc.
2. Card style feature menu  
Press and hold to switch between different feature cards, such as Music and Weather.

3. Home  
Tap this button or pinch five fingers together on any page on the center display to return to the Home page.
4. Vehicle Settings  
Sets the common features of the vehicle.  
You can also swipe right on the home page to enter the Quick Access page, where you can use common features and customize shortcuts.
5. Climate and Comfort Control panel  
Quickly sets the climate, seats and comfort settings.
6. Application launcher  
You can select different applications here, such as Weather, Photos, etc.
7. Volume settings  
Quickly sets the system and media volume.

### ***Controls on the Rear Display***

You can control features and media related to the rear seats from the rear display. The following features are provided on the rear display:

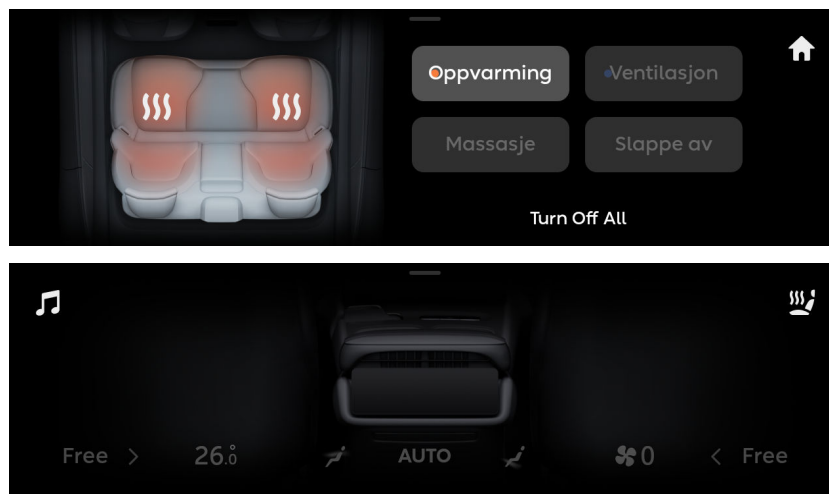

- Swipe horizontally left and right or swipe left and right along the edge of the screen to switch between different vehicle features, such as Climate Control, Seat Comfort, Ambient Lighting, Fragrance, etc.
- Swipe down along the top edge of the screen to enter the Quick Access page, where you can set screen lighting, volume, and screen saver.
- Swipe up along the bottom edge of the screen to enter the Media page, where you can control the current media playback.

## Event Data Recorder (EDR)

This vehicle is equipped with an Event Data Recorder. The Event Data Recorder is mainly used to record data from certain crashes or crash-like situations, such as airbag deployment or collision with an obstacle on the road. Such data can help understand the operation of vehicle systems.

The Event Data Recorder on this vehicle can temporarily or permanently store technical information about the vehicle status, events, and faults. This technical information usually includes the status of the following components, modules, systems, and environments:

- Statuses of the vehicle and its individual components, such as the speed, acceleration, and vehicle identification number.
- Functional statuses of important system components, such as seatbelt buckles.
- Vehicle responses under special driving conditions, such as airbag deployment or stability control system intervention.
- Data for a period of time before and after a collision, such as braking, acceleration, steering operation, time of occurrence, occupant protection device deployment and seat belt status.

Such data helps better understand how collisions and injuries occur.

Note: The vehicle speeds recorded by the Event Data Recorder are from the brake control unit.

This data is only a natural attribute for identifying and fixing faults and optimizing vehicle features. It cannot be used to reproduce movements on the road. When performing servicing related tasks such as repair and maintenance, service personnel and manufacturers can read this technical data from the memory of events and fault data with special diagnostic devices. After troubleshooting, the system deletes or continues to overwrite the information in the memory storage.

When using the vehicle, these technical parameters and other information related to the vehicle, such as accident records, vehicle damage, and evidence (which may require the intervention of a specialist), can be read through the diagnostic devices at NIO.

If the Event Data Recorder does not have enough space to record an event, the current event data will overwrite unlocked previous event data in chronological order. Locked events will not be overwritten by subsequent events.

**Note**

NIO will not disclose any information recorded in the system to a third party without your permission or consent.

## System Update

Your vehicle comes with a remote upgrade system. When the vehicle is connected to the Internet, you can enter Settings from the bottom of the center display and tap **General > System Update** to update the vehicle system software. and keep your vehicle system up to date. You will be notified when a software update is available. You can choose to start the update immediately or . During the update, the center display shows the time needed to complete the process (which depends on the size of the update package).

### Caution

- System upgrades are only available when the vehicle is logged in with the owner's account.
- A system upgrade can only be started when the vehicle is in PARK (the gear selector is shifted to P) and connected to the Internet.
- System upgrades will consume a certain amount of power. Before starting an upgrade, please ensure that the vehicle's battery level is above 20% and plan your travel arrangements accordingly.
- If you start a system upgrade while charging, the vehicle will stop charging automatically. After the upgrade is completed, you can resume charging manually.
- During a system upgrade, all of the vehicle's features except for locking/ unlocking with the smart key fob will not be available. You cannot drive the vehicle during a system upgrade.
- System upgrades may provide new features, changes to existing features, or changes to the way in which some features operate. Please read the release notes carefully after any upgrade to learn more about new or updated features. If you are unfamiliar with any function in a system update, please use the function with caution to avoid injury or property damage due to misuse.
- If the system upgrade is unable to start or is not successful, please contact NIO immediately.
- Do not modify vehicle components or change the software of the vehicle without authorization. Failure to comply may result in injury or property damage.

## Resetting All Settings

When you need to sell the vehicle, you can erase all content and settings by entering Settings from the bottom of the center display, and tap **General > Reset All Settings**.

The following data and settings will be erased, including vehicle settings (such as settings for seats, side mirrors, and climate control), driving settings (such as ADAS and driving mode), NOMI settings, system settings (such as time and date), navigation settings, media playlists, and photos & videos.

### Caution

- Only the vehicle owner can reset all settings. The operation can only be performed when the vehicle is stopped.
- When resetting all settings, the instrument cluster and the center display will go black and blink. Do not drive the vehicle when resetting the system. Otherwise it may cause unpredictable consequences.
- After resetting, the vehicle will be restored to the inactivated state. You need to reactivate the vehicle to use it.
- Resetting will erase all your settings, application data and all content, including photos and videos, stored in the vehicle. It is recommended to back up your important files before resetting. You can enter the **Album on the center display** , select files you need and choose **Export to USB**.
- Resetting will not erase your personal data stored in the cloud, such as driving habits, frequent navigation addresses, and music playlists.



## Basic Operation

### ***Starting the vehicle***

The vehicle can get ready to drive when the following conditions are met:

1. The driver is seated.
2. Close the driver's side door or press the brake pedal.

The driver can start the vehicle in many ways such as with the smart key, NFC card, and mobile phone NFC.

If the mobile phone NFC or NFC card is used, place the mobile phone with the NFC key or NFC card on the wireless charging board, keep the mobile phone unlocked and fit it into the wireless charging board, and then try to engage the gear and start the vehicle.

### **Caution**

When starting the vehicle via an NFC card, ensure that your phone or NFC card is placed on the wireless charging pad.

### **Caution**

When using an NFC card, ensure that your phone is turned on and remains unlocked.

Since Apple Inc. does not allow third parties to access NFC, iOS is not supported at present.

### **Caution**

In case of a collision, the impact force is transmitted to the driver's lower leg through the accelerator pedal, causing personal injury. Therefore, the accelerator pedal has a fracture limiter groove to protect the driver's legs and personal safety.

In unexpected situations where a great lateral external force is applied to the vehicle, the accelerator pedal may break due to the limiter groove design.

### ***Gear shift***

After pressing the brake pedal and toggling the gear shifter into the D or R gear, the digital instrument panel displays **READY**, indicating that power output is ready. After the shift, the digital instrument panel will display the real-time gear position

of the vehicle. If the shift fails, the digital instrument panel will prompt you to confirm the current gear.



You can use the PRD gear shifter to control gear switching, including:

- Drive gear (D gear): used in normal driving mode
- Reverse gear (R gear): can only be engaged in the parking state
- Parking gear (P gear): prevents slipping in the parking state

Go to the Settings page from the control bar at the bottom of the central display, and tap **Sound >Shift prompt tone** to enable or disable the tones.

For example, the vehicle can be switched to neutral gear (N gear) in specific conditions such as while pushing the vehicle and automatic washing.

Go to the Settings page from the control bar at the bottom of the central display, and tap **Driving >Towing/Washing mode** to enable or disable this function.

### Caution

Always confirm the gear on the digital instrument cluster after shifting gears. If there are any inconsistencies with the gear displayed, double confirm or shift gears again.

### Caution

You can only shift into PARK when the vehicle is stationary and the brake pedal is pressed.

## Warning

Before leaving the vehicle or stopping it on a slope, ensure that the gear is shifted into PARK. If you have not confirmed the gear on the digital instrument cluster, the vehicle may roll away.

## **Electrical Parking Brake (EPB)**

When switching to the parking gear, the parking brake will be automatically activated, and the digital instrument panel displays , indicating that the Electrical Parking Brake (EPB) has been enabled.

When locked from the outside of the vehicle, the vehicle's power will be automatically turned off, and the central display and digital instrument panel will be shut down at the same time.



You can switch the vehicle to the parking gear in the following ways.

- Press the P shift button on the side of the shift lever in the center console.
- Go to the Settings page from the control bar at the bottom of the central display, tap **Driving>Electrical Parking Brake (EPB)**, and slide the button to park.

When the digital instrument panel displays , it indicates that the brake system is faulty. Please drive carefully and contact the NIO Service Center for maintenance.

## Drive Modes

Five basic drive modes are available on your vehicle: Sport+, Sport, Comfort, Eco and Custom. You can set these modes in terms of acceleration, energy recovery, suspension height and stiffness, steering effort, and air conditioning.

A different drive mode brings in different driving performance, thereby optimizing driving experience and meeting your demands in particular cases.

	Sport+	Sport	Comfort	Eco	Custom
Acceleration	3.9 seconds	5.9 seconds	7.9 seconds	9.9 seconds	3.9 seconds, 5.9 seconds, 7.9 seconds, 9.9 seconds, or 12.9 seconds
Regenerative Braking	Low	Low	Low	Standard	Standard, low or very low
Suspension Height	Low	Standard	Standard	Standard	Standard or low
Suspension	Stiff	Medium	Soft	Soft	Stiff, medium or soft
Steering Effort	Prudent	Standard	Comfort	Comfort	Prudent, Standard, Comfort
Climate Control	Standard	Standard	Standard	Eco	Standard or Eco
Note: Sport+, Sport, Comfort and Eco modes are fully customizable except for acceleration performance.					

In ECO Mode, the system will give priority to energy efficiency. In this case, the climate control feature is restricted compared with that in other modes. Manually set to a higher or lower temperature when necessary.

Enter Settings from the bottom of the center display, and tap **Driving > Drive Mode** to select a drive mode.

## Scenario Assist

### ***Snow Mode***

When driving on icy roads, you can turn on Snow Mode to change the way your vehicle is driven and prevent slipping.

Enter Settings from the bottom of the center display, and tap **Driving > Snow Mode** to enable or disable the feature.

You can switch to any regular drive mode, or tap Snow Mode again to turn off this feature.

### ***Easy Pass Through***

Easy Pass Through assists in driving on complex roads with potholes, hard shoulders, or packed snow, etc.



Enter Settings from the bottom of the center display, and tap **Driving > Easy Pass Through** to enable or disable the feature.

When the feature is enabled, the ride height of your vehicle will be raised to the maximum.

Easy Pass Through will be automatically deactivated in the following situations:

- The speed exceeds 30 km/h.
- The drive mode is changed.

### ***ECO+ Mode***

ECO+ Mode reduces the power consumption of the vehicle and extends the range by disabling optional features and meeting the minimal driving needs.

In ECO+ Mode, the maximum speed of the vehicle is limited, driver assist features are temporarily unavailable, and comfort features such as air conditioning and ambient lighting are limited.

Enter Settings from the bottom of the center display, and tap **Driving > ECO+ Mode** to enable or disable the feature.

You can switch to any regular drive mode, or tap ECO+ Mode again to turn off this feature.

## Feature Settings

### **Autohold**

The function of Autohold is to keep the vehicle stationary for temporary parking when the brake pedal is released.

Go to the Settings page from the control bar at the bottom of the central display, tap **Driving > How to activate Autohold** and select the corresponding method to activate Autohold.

- **Flooring:** Step on the brake pedal until the vehicle stops, then slightly release and step on the pedal again to activate Autohold
- **Auto activation:** Step on the brake pedal until the vehicle stops, and then Autohold will be automatically activated.

When Autohold is activated, the  icon will be displayed on the digital instrument panel. When active, you can step on the accelerator pedal or the brake pedal to deactivate Autohold.

### **Caution**

The Autohold mode will not be enabled when the vehicle is in REVERSE (R gear). You still need to use Full Press Activation to park.

You can also floor the brake pedal to activate Autohold in an emergency.

You can also activate Autohold when parking on an uphill road, where the braking system will provide sufficient braking force to keep the vehicle stationary in accordance with the degree of the slope.

### **Caution**

The grade of the slope shall not exceed 20%.

### **Emergency Braking**

In the event of a brake pedal failure, you can activate Emergency Braking by pressing the Park gear button, which will produce full braking deceleration under normal circumstances to stop the vehicle.

- Press and hold the Park gear button to activate Emergency Braking.



- Release the Park gear button, or step on the accelerator pedal to deactivate Emergency Braking. To re-activate Emergency Braking, you will need to press the button again.

### Caution

Do not activate Emergency Braking unless in emergency situations where the brake pedal malfunctions or is stuck.

### Warning

When driving in winter, or on roads with sharp curves or uneven surfaces, activating Emergency Braking may cause the vehicle to drift or slip. Please drive with caution.

### ***Hill Start Assist***

Hill Start Assist (HSA) prevents your vehicle from rolling backwards when starting uphill.

When your foot switches from the brake pedal to the accelerator pedal, the pressure on the brake pedal will be maintained in the brake system for a maximum of 2 seconds. The temporary braking effect will disappear after 2 seconds or when you accelerate.

### ***Enhanced Head-Up Display System***

The enhanced head-up display system (HUD) mirrors and projects relevant information such as the vehicle speed, navigation, traffic signs, cruise signs, and Autohold through the front window glass above the digital instrument panel.

### Caution

At certain angles, sunlight may lead to tiny bright specks on the windshield when refracted and reflected by the front windshield and Heads-Up Display. These specks may disappear with changes in light angle, driving direction, slope, etc.

When driving in the same direction for a long time, you can adjust the height of the Heads-Up Display to get rid of these specks.

Go to the Settings page from the control bar at the bottom of the central display, and tap **Display>Enhanced Head-Up Display System** to configure.

- Turn on HUD

- Active brightness adjustment
- Height
- Inclination

Once the height is set, the system will automatically memorize it.

Go to the Settings page from the control bar at the bottom of the central display, and tap **Display>Switch Navigation Mode**, and select different navigation display modes to meet different information acquisition requirements.

- Auto Mode: actively switches between Detailed Mode or Indirect Mode according to road conditions
- Detailed Mode: displays the driving route and current location in real time in the form of a small map
- Simple Mode: provides guidance information for road navigation only

### ***Start Reminder***

After the vehicle stops by following the vehicle ahead, if the vehicle ahead drives away, Start Reminder will send you an alert.

Go to the Settings page from the control bar at the bottom of the central display, and click **NIO Pilot > Start Reminder** to turn this function on or off.

While enabled, when you manually stop the vehicle as the vehicle ahead stops, and do not follow as the vehicle ahead drives away, Start Reminder will send you an alert.

### **Warning**

Lead Vehicle Start Alert serves as a reference only and cannot substitute your visual observation. You must always pay attention to the traffic conditions and road conditions, and drive at an appropriate and safe speed in compliance with applicable traffic laws and regulations.

## Digital Video Recorder (DVR)

It can be used to record videos during driving and also provide evidence for traffic accidents.

The Digital Video Recorder (DVR) function includes cyclic video recording, emergency video recording and Quick Video Recording.

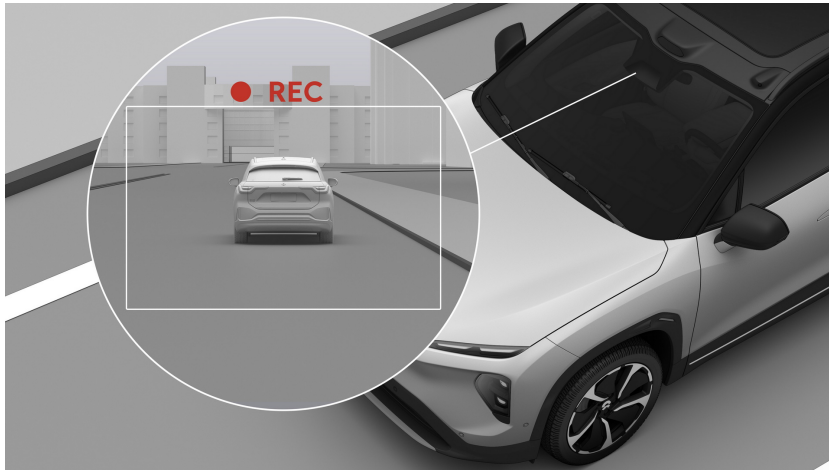

### Caution

The Digital Video Recorder does not work when the vehicle is parked and powered off.

### ***Cyclic video recording***



The Digital Video Recorder (DVR) includes the main view Angle and the left and right surround view angles, supporting simultaneous recording and real-time previews. The video player supports the zooming function, which can play while zooming in. It also supports screenshots, which can be saved in the photo album, and the photos can be uploaded to the cloud and shared to the mobile phone.

- Main view: only records the main view angle of the camera, which supports a maximum resolution is 3840x1696 and has a picture fluency of 30 frames per second.
- Five view angles: records all view angles of the camera, with four surround view cameras that support a maximum resolution of 1280×1000 and have a picture fluency of 30 frames per second.

The longest continuous cyclic recording time for the main view of Digital Video Recorder (DVR) is about 10 hours, and 5.7 hours for the five view angles. When the corresponding time is exceeded, the original video file will be overwritten.

The contents of the cyclic video recording will be stored in the **Photo album >Cyclic video** folder. If you want to save a specific video file, insert a storage device such as a USB flash drive, select the file, and transfer it to save it in the device.

Go to the Settings page from the control bar at the bottom of the central display, and tap **Safety >Digital Video Recorder (DVR)** to enable or disable this function.

- When the function is enabled,  will be displayed at the top of the central display.
- When recording begins,  will be displayed at the top of the central display.
- When the function is disabled,  will be displayed at the top of the central display.

The Digital Video Recorder (DVR) supports recording and watermarking functions, which are disabled by default and need to be enabled manually.

In the Settings for the recording page of the Digital Video Recorder (DVR), Tap **Sound Recording** to enable or disable the function.

In the Settings for the recording page of the Digital Video Recorder (DVR), Tap **Traffic Data Watermarking** to enable or disable the function.

When the recording function is enabled,  will be displayed at the top of the central display, and the Digital Video Recorder (DVR) can record.

When the Traffic Data Watermarking function is enabled, in addition to time watermarking, the video will add the watermarking of traffic data such as vehicle speeds, gears and turning signal lights to help judge the circumstances of an accident.

### ***Emergency video recording***

The emergency video recording function can record video images in the vehicle's memory. If the automatic emergency braking is triggered or the airbag is detonated, the emergency video will be recorded and saved.

The emergency videos include videos recorded 30 seconds before the emergency and 60 seconds after the emergency. The emergency video recordings will be stored in the **Photo Album - Emergency Video** folder.

### ***Quick Video Recording***

The Quick Video Recording function covers most manually triggered scenes, such as a violation of regulations, deliberate provocations, fun, etc., which can be saved in time, recorded conveniently and found quickly.

Go to the Quick Settings page by swiping right on the home page of the central display, tap Quick Video Recording to start recording.

You can also press and hold the middle button on the right side of the steering wheel to customize it as the "Quick Video Recording" function. After saving the Settings, press and hold the middle button on the right side of the steering wheel to trigger Quick Video Recording.

The Quick Video Recording saves videos recorded 30 seconds before and 60 seconds after it is triggered. The Quick Video Recordings will be stored in the **Photo Album - Emergency Videofolder**.

## Pedestrian Warning System

When driving at a low speed (normally below 30 km/h), the vehicle emits a sound to alert other road users such as pedestrians and other vehicles of your presence.

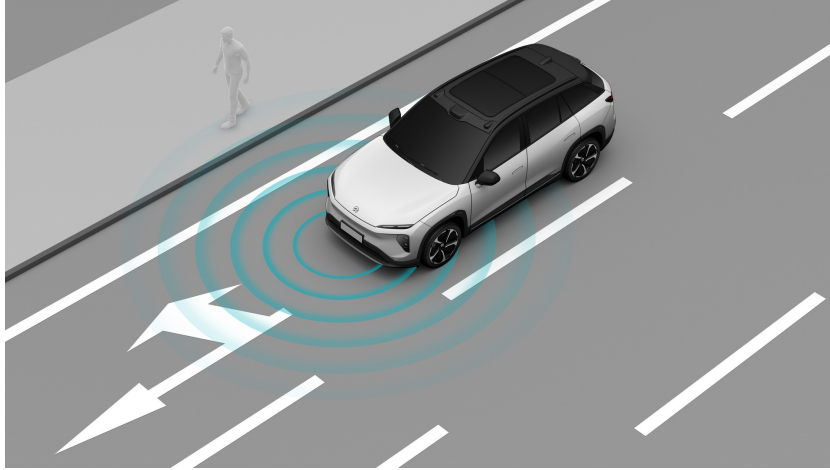

Swipe right on the home page to visit Quick Access, and tap **Pedestrian Warning System** to enable or disable the feature.

When you disable this feature manually, an alert message appears on the center display. Tap it to disable the feature. The feature is enabled by default next time you drive the vehicle.

When this feature is enabled:

- When driving at a speed between 0 km/h and 20 km/h, the sound gets louder as your speed increases.
- When driving at a speed between 20 km/h and 30 km/h, the sound gets weaker as speed increases.
- When driving at a speed over 30 km/h, the vehicle stops emitting the sound.
- When driving at a speed below 25 km/h, the vehicle will emit the sound again.

### Caution

Pedestrian Warning System can only be disengaged when it is unnecessary to emit a sound if there are no pedestrians nearby.

## Parking Camera and Parking Assist

Parking Assist monitors the surrounding conditions of vehicles at low speeds through ultrasonic sensors to help you drive safely.

During parking, your vehicle will warn you with warning tones and images according to the distance between obstacles and the front or rear of the vehicle.

Distance	Frequency of the warning tones	Color
1.2-1.5m	None	White
0.9-1.2m	0, 1, 2 times per second	White
0.6-0.9m	0, 2, 3 times per second	Orange
0.3-0.6m	3, 4, 5 times per second	Orange
Less than 0.3m	High-frequency beeps	Red

### Warning

Parking Assist serves as a reference only, and cannot substitute your visual observation.

As a driving assist feature, Parking Assist cannot handle all situations in all traffic, weather and road conditions. You must always pay attention to traffic and road conditions, and make your own decision on whether to use Parking Assist only after your safety is ensured.

It is always your responsibility to ensure that the vehicle is driven in a safe manner and complies with applicable traffic laws and regulations.

### ***Enable/disable the Parking Camera***

You can enable the parking camera in the following ways:

- Swipe right from the main page of the central display to enter the shortcut settings page, and click **360 surround view** to open the 360° panoramic camera.
- Enter the application centre from the central display and click **Parking** to open the memory view (360° panoramic camera or dual view camera).

- Engage the vehicle in R gear and open the memory view (360° panoramic camera or dual view camera).
- Press and hold the middle button on the right side of the steering wheel, set the custom function to **360 surround view**, and then open the 360° panoramic camera.
- Wake up NOMI, enable **Parking** with your voice, and open the 360° panoramic camera.

You can click on the upper right side of the parking camera page and select to turn off the warning tone. At the same time, you should bear all the risks caused by turning off the warning tone.

### Caution

Parking Camera will be automatically disabled when your vehicle is in PARK or moving faster than 21 km/h.

You can also disable Parking Camera manually by grabbing with five fingers on the center display or by tapping the Off button in the upper left.

### Caution

The range of the vehicle's front and rear detection do not exceed 150 centimeters.

### Warning

Under the following circumstances, the ultrasonic sensor is limited, and information such as "UPA sensor front failure", "UPA sensor rear failure", and "UPA sensor system failure" may appear. Which include but are not limited to:

- One or more ultrasonic sensors are damaged, misaligned, or obstructed (such as by mud, ice, snow, or vehicle cover).
- Severe weather such as rain, snow, fog, and haze affects the performance of the ultrasonic sensor.
- The sensor is affected by other electrical equipment or devices that can cause interference.

### Caution

Due to the characteristics of the ultrasonic sensor, some situations may cause the ultrasonic sensor to alarm falsely. This kind of false alarm will disappear as the



road condition changes and will not affect normal driving. Which include but are not limited to:

- Rough asphalt, cement, or cobblestone road, waterlogged road, and other uneven roads.
- Inductive coils embedded in the road, etc.
- Interference caused by nearby large vehicles, construction machinery, etc.



### **Warning**

Ultrasonic sensor detection may be restricted for certain obstacles, including obstacles that are low or narrow, or which come from the top or side of the vehicle. In these cases, you should always pay attention to your surroundings. Failure to do so may result in property damage or personal injury. These obstacles include but are not limited to:

- Pedestrians, children, and animals
- Open parking locks, low stone blocks, low cylinders, thin rods, pointed objects, potholes, etc.
- Height restriction barriers, height bars, or suspended structures
- Obstacles on the side of the vehicle's body that may cause a collision or scratches
- Bicycles, corners of walls and square columns in parking lots, etc.

### ***Parking camera page***

The parking camera consists of two pages: 360° panoramic camera and dual view camera. Click the button on the upper left side of the 360° panoramic camera to switch the pages.

Button	Function
	Switch to the dual view camera.
	Switch to the 360° panoramic camera.

### ***Parking camera view***

After opening the dual view camera page, you can switch to the front view and rear view by switching between the drive gear (D gear) and the reverse gear (R gear), or click the 3D view, front view, rear view, left and right hub view, front hub

view and rear hub view in the lower left area of the central display page to switch between different views.

When using the 3D view, you can adjust the viewing angle by swiping with one finger, adjust the viewing distance by zooming in with two fingers and adjust the viewing height by swiping up and down with two fingers.

### Caution

When the center display shows the left/right wheel view, front wheel view, or rear wheel view, the parking view will not change when you shift gears.

### ***Adjusting the Brightness of the Parking Camera***

#### Auto Adjustment

Click "Quick Control" in the parking camera interface to find "Brightness Adjustment", then select "Auto". The brightness of the central display can be automatically adjusted along with the brightness of the environment.

#### Manual Adjustment

Click "Quick Control" in the parking camera interface to find "Brightness Adjustment", then slide the brightness adjustment slider to manually adjust the brightness of the central display. Before manually adjusting the brightness of the central display, please ensure that the "Auto" switch is OFF.

### ***Dynamic transparent chassis***

Dynamic transparent chassis refers to a transparent effect that can be presented, via technical processing, on the road images collected by the camera in advance when the vehicle is moving, and transmitted to the central display of the vehicle so that the road conditions can be seen in the vehicle.

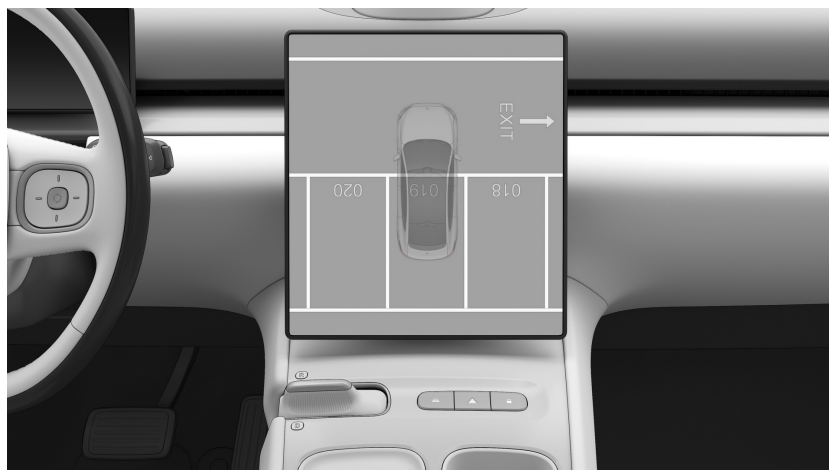

You can enable this function on the Settings page of the parking camera. After the dynamic transparent chassis is enabled, the transparency of the model during driving can be customized, which includes four options: "opaque", "low", "medium" and "high".

### **Caution**

The Dynamic Transparent Chassis cannot detect possible environmental changes under the chassis when the vehicle is stationary. Please drive with caution and always pay attention to your surroundings to avoid damage to the vehicle.

### ***Blind area around the vehicle model***

Due to the relative relationship between the camera installation position and the body, there is a blind area of about 30cm around the vehicle in the 360° panoramic camera page. Please pay attention to the actual situation around your vehicle when parking.

### **Caution**

The blind spot indication shown in the surround view image serves as a reference only, and cannot substitute your visual observation.

You must always pay attention to traffic and road conditions, and park the vehicle only after your safety is ensured.

Due to the existence of blind spots, some low objects close to the vehicle may not be fully displayed. Please pay attention and drive carefully.

## Seat Belts

### ***Seat Belt Instructions***

Seat belts are one of the most important ways to protect occupants in case of an accident. Using seat belts together with airbags can reduce the risk of severe injury if a collision occurs.

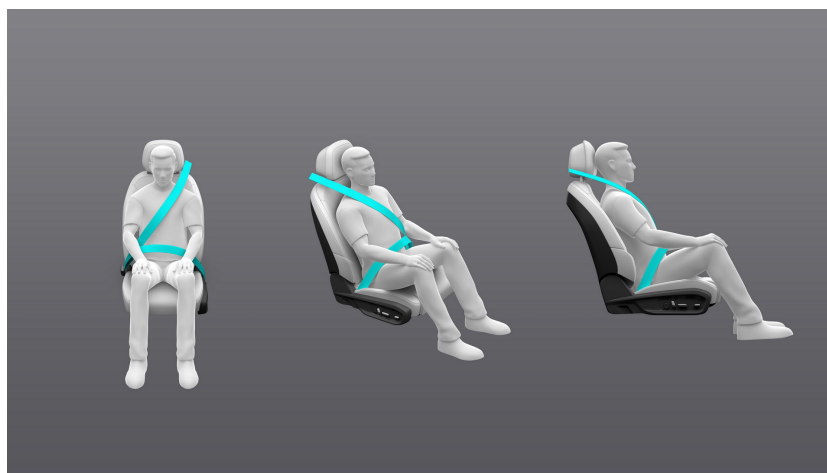

Both front and rear seats feature seat belts with pretensioners (dual-stage for front seats). The pretensioners rapidly retract and latch seat belts the instant a severe collision occurs, thereby providing increased protection for occupants. The force limiter can then prevent the seat belt from exerting too much force on the occupant and minimize belt-inflicted injury.

### **Warning**

- Seat belts should be worn correctly by all occupants at all times. Failure to do so may result in severe injury or death.
- Do not unbuckle the seat belt when driving. Doing so can increase the risk of severe injury if a collision occurs.
- Avoid contaminating the seat belt or obstructing the belt latch. Failure to do so can impair the functionality of the seat belt.
- Check the condition of your seat belt carefully before use to ensure that no components show any sign of wear, aging, or damage. If any damage is found, do not continue to use the seat belt and replace it immediately.
- Do not attempt to repair a damaged seat belt yourself. Do not remove or install seat belts in any way.
- Never secure more than one person with a single seat belt. It is dangerous to put a seat belt around a child being carried on an occupant's lap. Doing so can cause further injury to the child if a collision occurs.

- Seat belts that have been stretched and deformed during an accident must be replaced immediately, even if there is no visible damage.
- Seat belt pretensioners that have been activated during an accident must be replaced immediately. Even if they are not activated in certain accidents, it is suggested to drive to NIO for inspection or even replacement if necessary.
- Do not drive with the backrest reclined to an extreme degree. Doing so can impair the protective function of the seat belt.

### ***Seat Belt Warning Light***

All seats are equipped with seat belts. When the driver is seated (with doors closed or the brake pedal pressed) or is driving, the seat belt warning light  on the digital instrument panel turns on when anyone in the front is unbuckled to ask the driver and the front passenger to buckle up. If the vehicle is driven at a speed over 22 km/h and the seat belts are still not fastened, the warning light will flash, and a chime will sound. After seat belts are fastened, the warning light will turn off, and the chime will stop. If the belts remain unfastened, the chime will stop after 100 seconds, but the warning light will stay on.

When the driver is seated (with doors closed or the brake pedal pressed), the seat belt warning light  on the digital instrument cluster will turn on if a passenger in the rear is unbuckled to ask him/her to buckle up. After the seat belt is fastened, the warning light will turn off.

When rear seat belts are not fastened:

- If the vehicle is in motion with rear seat belts unfastened, the warning light is on for 33 seconds before being turned off automatically.
- If the vehicle is driving over 22 km/h, the warning light flashes, and a chime sounds. The warning light turns off after all occupants are buckled up.
- If passengers in the rear seats remain unbuckled, the warning light automatically turns off after 33 seconds.

### **Warning**

If the seat belt reminder malfunctions, do not use the seat and contact NIO immediately for inspection.

### ***Wearing Seat Belts***

Use the seat belts correctly as follows:



1. Pull the seat belt by the belt buckle evenly across your body, and ensure that the shoulder strap is placed over the shoulder while the lap strap is positioned across the pelvis. Never place the seat belt across the neck or abdomen. Insert the belt buckle into the belt latch until you hear a click indicating it is locked in place.

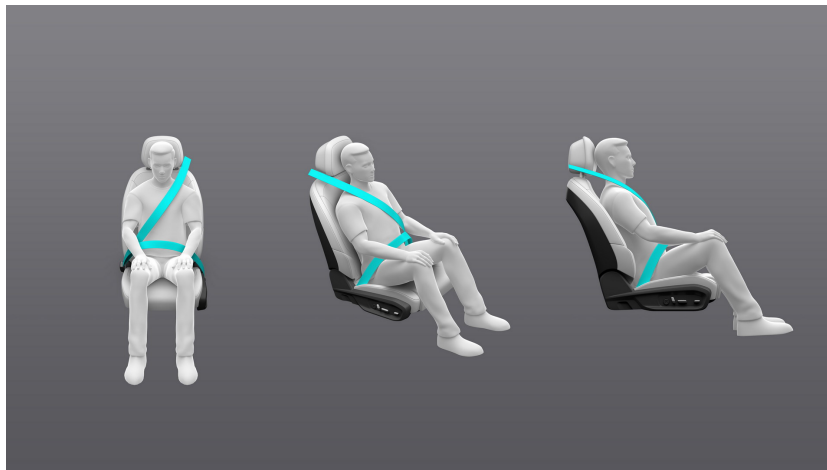

2. Press the button, and slide the belt upward or downward to adjust the seat belt height. Release the button when the belt is at an appropriate height. To check if the belt is securely locked in place, pull firmly on the shoulder portion of the belt.

To release the seat belt, press the red button on the belt latch to pop out the belt buckle. Guide the belt back by hand so that it can roll up more easily.

### Warning

- Ensure that the backrest and head restraint are positioned correctly before wearing a seat belt, so that the seat belt can protect the occupant to the fullest extent possible.

- A seat belt that is either too loose or too tight can cause injury if a collision occurs.
- For a pregnant occupant, the seat belt must rest evenly across the chest and as low and flat as possible across the hips. Failure to do so can cause severe injury to both the unborn fetus and the mother if the seat belt tightens in the event of an accident.

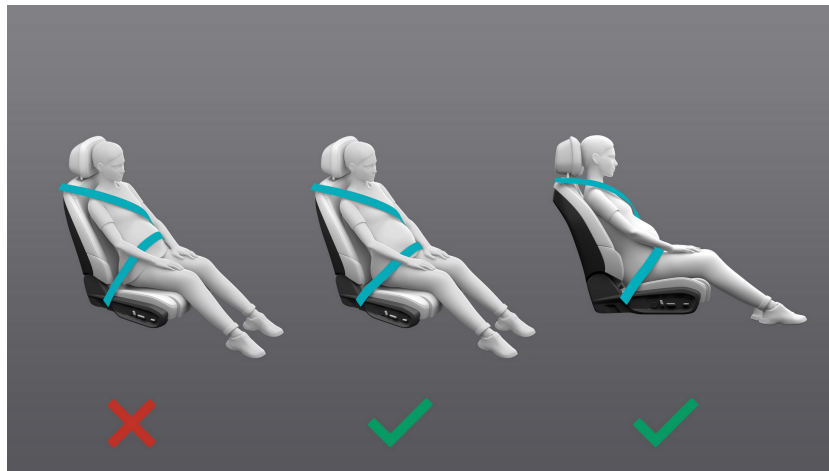

## Airbags

### ***Airbag Instructions***

As a restraint system, the airbag is a supplement to the seat belt. Airbags can quickly inflate in the event of a severe accident to protect the head and chest of the occupant and reduce injury severity. However, they cannot prevent injuries to limbs and body surface. Occupants enjoy maximum protection only when both airbags and seat belts are used appropriately.

Your vehicle is equipped with collision sensors. In case of a front or side collision that meets the conditions of deploying the airbag system, the corresponding airbags will be deployed. The gas generator inside the airbag will be enabled to release gas at a certain pressure to open the airbag cover and fill the entire airbag, forming a protective buffer layer to protect occupants and reduce the risk of injury or death.

The airbag system includes front airbags and side airbags. The presence of an airbag is indicated by the word "AIRBAG" in all places where the airbag is located.

- Front airbags include front head airbags that are located in the steering wheel and on the headliner of the passenger side;
- Side airbags include front side airbags located on both sides of the driver seat and on the outside of the front passenger seat and curtain airbags located on the headliner on both sides from A-pillar to C-pillar.

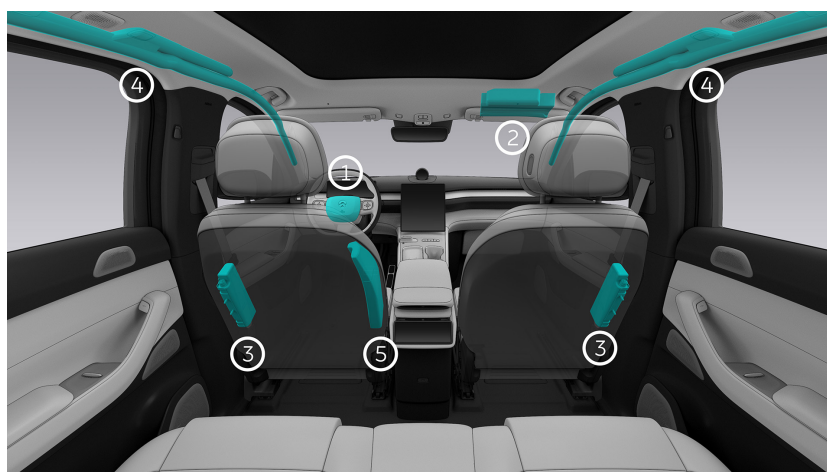



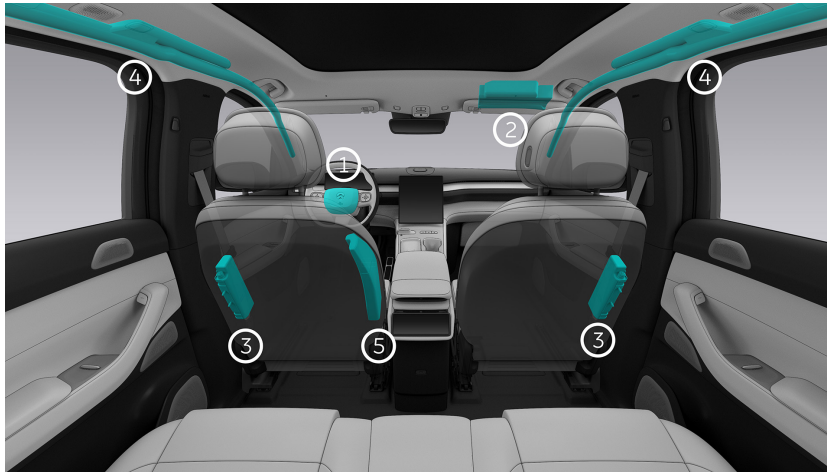

1. Driver front airbag
2. Front passenger front airbag
3. Seat-mounted side airbags
4. Curtain Airbags
5. Front middle airbag

### Warning

- Airbags are a supplementary restraint system and cannot replace seat belts. The airbag can only maximize your safety when used in conjunction with the seat belt. Thus, all occupants should always correctly wear their seat belt and sit in the correct position.
- The driver should sit at least 25 cm away from the steering wheel, since the airbag may injure the driver when deployed with great force.
- Children must not sit in the front passenger seat if the front passenger airbag is enabled. In the case of an accident, the impact of the airbag when deployed may cause severe injury to children.
- Do not place any objects on the front passenger seat. These objects will enter the deployment area and be ejected if the airbag deploys in the event of emergency braking, which may injure occupants.
- The airbag system can only provide protection once. If the airbag has been deployed, you must have it replaced; during certain accidents, the airbag may not deploy. However, to ensure that the airbag system works properly, please contact NIO immediately for inspection or replacement if necessary.
- If any damage or fractures are found on the airbag cover, do not use the vehicle and contact NIO immediately.

- If the airbag system has never been deployed for a period of ten years from its production date, please visit NIO to have it replaced; a record of the airbag system's replacement needs to be kept and given to the new owner when the vehicle's ownership is transferred.
- Installing or removing airbag system components, including airbag labels, is prohibited.
- Smoke and fine powder may be produced when the airbag deploys. Even if the fine powder is nontoxic, it may still make occupants feel uncomfortable.
- When using seat covers, avoid the area around the side airbags for the front seats. Doing so may impair the protective function of the side airbags.
- Do not place any objects in the deployment area of the curtain airbags (including pillars, headliner or handles). Occupants should not lean against the doors. Doing so may result in injury if a curtain airbag deploys.
- Do not place any hard objects (including clothes hangers, fruits, or glass bottles) on the garment hooks in the vehicle. Doing so may result in injury if a curtain airbag deploys.
- Never place your feet, knees or other body parts on or near the airbag covers. Do not place or hang any objects on or near the airbag covers. Doing so may impair the functionality of the airbags and may result in injury if an airbag deploys.
- Never install any electronic devices (such as ETC) on the front windshield on the passenger side. Doing so may result in injury if the front passenger airbag deploys.
- Never place, hang or install any objects on or near the instrument panel on the passenger side. Doing so may result in injury if an airbag deploys.
- Never modify the headliner of the vehicle. Doing so may impair the functionality of the front passenger airbag and curtain airbag, and result in injury if they deploy.
- Never place or hang any heavy or sharp-edged objects on the front passenger sun visor. Doing so may result in injury if the front passenger airbag deploys.
- The smoke and dust generated during the rapid airbag deployment may cause skin or eye irritation/scalds/burns, and the airbag fibers may cause skin scratches or burns.

### ***Conditions for Deploying Airbags***

Airbags will inflate in the following cases:

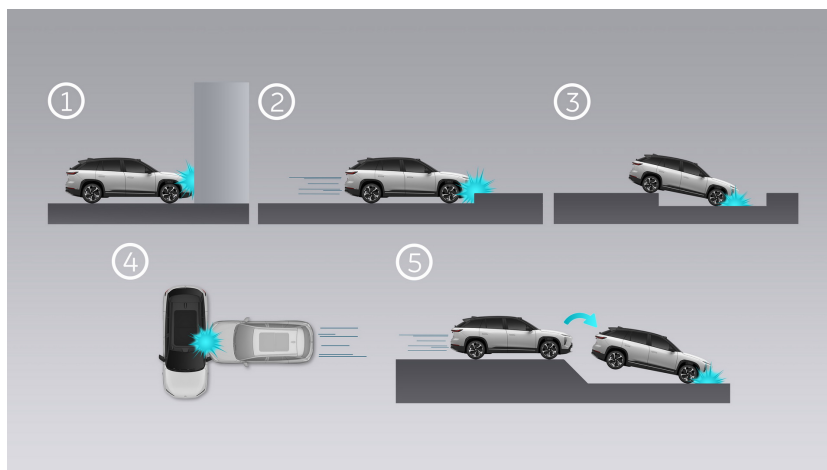

1. The vehicle hits a wall or vehicle at a high speed.
2. The vehicle hits a hard curb.
3. The vehicle falls into a deep ditch.
4. The vehicle is crashed by another vehicle at a higher speed from the side.
5. The vehicle jerks forward and hits the road hard.

In the following cases, airbags may not deploy and the occupants should be protected by wearing the seat belts correctly:

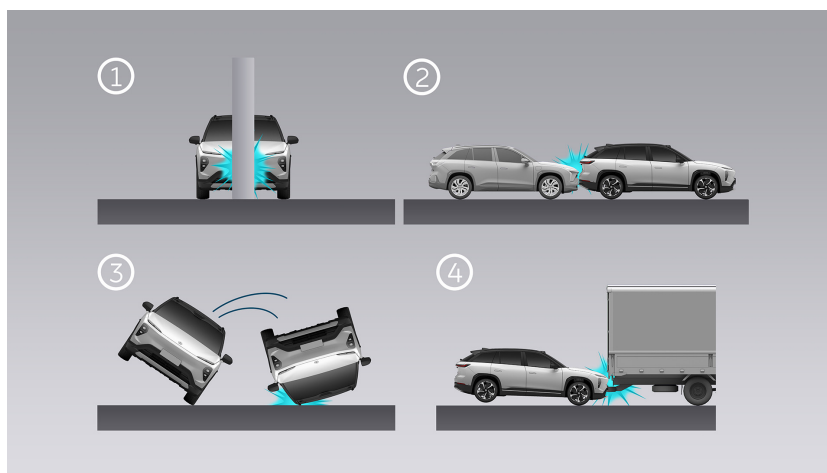

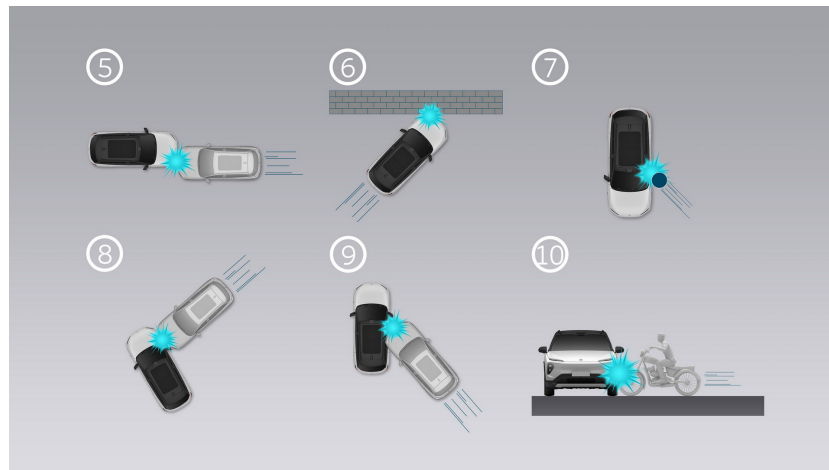

1. The vehicle hits a tree, pole, or other tall and thin objects.
2. The vehicle is hit by another vehicle in the rear.
3. The vehicle rolls over.
4. The vehicle collides with or slides under a truck.
5. The front corner of the vehicle collides with another vehicle.
6. The front corner of the vehicle collides with a wall.
7. The vehicle travels sideways into a pole.
8. The side of the vehicle front end is hit by another vehicle at a certain angle.
9. The side of the vehicle body is hit by another vehicle at a certain angle.
10. The vehicle is hit by another vehicle on the side.

### ***Airbag Warning Indicator***

An airbag warning indicator  on the digital instrument cluster displays the status of the airbags. If the indicator is on after the digital instrument cluster is turned on, do not use the vehicle, and contact NIO immediately.

### ***Disabling Front Airbags***

Since the airbags rapidly inflate and unfold with great force, the distance between the front airbags and front occupants should be at least 25 cm. If a child or an occupant with special medical needs is seated in the front passenger seat, Enter Settings from the bottom of the center display, and tap **Driving > Front Passenger Airbag** to disable the front passenger airbag. Then the  icon will appear at the top of the center display to remind you that the front passenger airbag has been disabled. This can reduce the risk of severe injury to the vulnerable.

***Actions to Take After Deploying Airbags***

When a collision occurs and the airbags are deployed, the vehicle will automatically take the following actions to ensure occupant safety:

- Unlocks doors to ensure that the occupants or rescue personnel can open the doors.
- Turns on the hazard warning lights to indicate the vehicle's location and alert other vehicles approaching from the rear.
- Cuts off the high voltage system to ensure occupant safety.
- Opens windows to prevent occupants from being trapped in the vehicle if it is submerged in water.
- Turns off Driver Seat Memory to prevent the seat from moving to a position that traps the driver.
- Turns on the reading lights, especially for the convenience of rescue at night.

## Child Protection Locks

Child protection locks are turned off by default and need to be set before turned on. Enter Settings from the bottom of the center display, and tap **Doors & Windows** to see the settings related to child protection locks.

### ***Manually Turning On/Off Child Protection Locks***

Tap **Child Protection Locks - Rear Doors/Windows**, which will be highlighted if the feature is on. Tap again to turn it off.

Failure to turn on or off the child protection lock of the corresponding door/window will result in a pop-up window appearing on the center display. Repeat the operation again until success.

### **Caution**

- When Child Protection Locks are on, please do not leave children unattended in the vehicle. Doing so may result in injury or death.
- After turning on Child Protection Locks, please check their status again.

## Child Seat

Children under the age of 12 or less than 1.5 meters in height must ride in a child seat or a booster seat in order to be sufficiently protected. Children must not be carried in an occupant's arms or sit in their lap.

Only use a child seat that is suitable for a child and complies with the relevant laws and regulations. Always check the label and instructions when choosing a child seat. When installing and using a child seat, always follow the relevant laws and regulations, the child seat manufacturer's instructions, and this manual.

### ***Important Instructions for Using a Child Seat***

Correct use of a child seat can significantly lower the risk of injury or reduce the severity of injury in an accident. Please pay attention to the following tips when using a child seat:

- It is not recommended to install a child seat onto the rear middle seat.
- Adjust the front passenger seat to the highest position when a child seat is installed onto it using the seat belt.
- Ensure that your child is riding in a child seat and wearing their seat belt correctly.
- Never allow your child to ride unprotected in the car.
- Do not seat more than one child in a child seat.
- Never allow a child to be held in an occupant's arms.
- Ensure that no hard or sharp objects are on the child seat. Failure to do so may cause injury during an accident.
- When installing a rear-facing child seat in the rear seat, you may need to appropriately adjust the corresponding front seat forward; when installing a front-facing child seat in the rear seat, you may need to appropriately adjust the headrest height.
- Never leave a child unattended, even if the child is secured in a child seat.
- Never allow a child to stand or kneel in their seat when driving. In case of accidents, the child could be thrown from the vehicle, which may cause injury or death to the child and other occupants.
- Always follow the child seat manufacturer's instructions for correct use of the seat belt for optimal protection.

- Always ensure that the child seat is correctly installed and secured even if a child is not sitting in the child seat. Failure to do so may cause injury to other occupants during a collision or emergency braking.
- When a child is seated in a child seat, to reduce the risk of injury, always ensure that the child does not lean on the door, outboard side of the seat, or pillar, or position their head or body below the roof cross beam where side airbags or curtain airbags will deploy when an accident occurs.

### ***Types of Child Seats***

Only use the approved child seat suitable for your child. Children over 1.5 meters in height can use the vehicle's seat belts. Child seats must comply with relevant regulations and standards.

**Table 1: CRS Table**

Weight groups allowed*	0, 0+, I, II, III	0, 0+, I, II, III		0, 0+, I, II, III	0, 0+, I, II, III	0, 0+, I, II, III
Seat position	Driver	1 <sup>st</sup> row Passenger		2 <sup>nd</sup> row left	2 <sup>nd</sup> row middle	2 <sup>nd</sup> row right
		Passenger Airbag OFF	Passenger Airbag ON			
Seating position suitable for universal belted (yes/no)	N/A	Yes <sup>(*a)</sup>	No	Yes	Yes <sup>(*b)</sup>	Yes
i-Size seating position (yes/no)	N/A	No	No	Yes	No	Yes



Table 1: CRS Table

Seating position suitable for lateral fixture (L1/ L2)*	N/A	No	No	No	No	No
Largest suitable rearward-facing fixture (R1/ R2X/ R2/ R3)*	N/A	No	No	R1/R2X/R2/R3	No	R1/R2X/R2/R3
Largest suitable forward-facing fixture (F1/ F2X /F2/ F3)*	N/A	No	No	F2X/F2/F3	No	F2X/F2/F3
Largest suitable booster fixture (B2/B3)*	N/A	No	No	B2/B3	No	B2/B3
Suitable for support leg	N/A	Yes	No	Yes	No	Yes

Notes:

Table 1: CRS Table

\* The weight group and child seat category are defined according to ECE R16 and R44, and you can find the category of a child seat on its specification. The child restraint system must be appropriate for the age, weight, and size of the child.

(a) If it is absolutely necessary for you to install a child seat to the front passenger seat, be sure to turn passenger airbag off. Adjust front passenger seat to highest position before install universal CRS on it. Adjust or remove headrest if it blocks the adjustment of CRS.

(b) It is forbidden to install a child seat with a support base or with a support leg on the middle seat of the 2<sup>nd</sup> row.

Table 2: Recommended Child Restraints by NIO

Group	Manufacturer	Model	Attachment
0 & 0+	Besafe	iZi CombiX4 ISOFIX	ISOFIX mounted with support leg, rearward-facing
Up to 13 kg			
I			
9-18 kg			
II	Cybex	Solution Z i-Fix	ISOFIX mounted, forward-facing
15-25 kg			
III	Graco	Booster Basic	ISOFIX with seat belt, forward-facing
22-36 kg			

NIO recommends to put your kids in the corresponding CRS on the 2<sup>nd</sup> row outer seating position, and the CRS should be mounted to vehicle with ISOFIX, support leg, or seatbelt. In order to have the best protection for your younger kids, please use a recommended rearward-facing CRS for kids weighing less than 18 kg.

Q6 recommended CRS: Cybex Solution Z i-Fix  
Q10 recommended CRS: Graco Booster Basic

### ***Choosing and Installing a Child Seat***

Refer to the following front airbag label fitted to the front passenger sun visor.



If you want to use a child seat in the front passenger seat, always ensure that the front passenger airbag is disabled. Enter Settings from the bottom of the center display, and tap **Driving > Front Passenger Airbag** to disable the front passenger airbag. In this case, the  icon appears at the top of the center display, notifying you that the front passenger airbag is disabled.

Secure your child with a child seat or seat belt that is appropriate for the age, weight, and height of the child on the rear outboard seats:

- Infants weighing up to 13 kg can be seated in a reclining rearward-facing child seat secured on the rear seats.



- Toddlers weighing between 9 kg and 18 kg are recommended to be seated in a rearward-facing child seat that is restrained by a safety cushion or integrated five-point harness and secured on the rear seats.



- Young children weighing between 15 kg and 25 kg can be seated in a forward-facing child seat that is restrained by a seat belt and secured on the rear seats.



- Children weighing between 22 kg and 36 kg and who are less than 1.5 meters tall can be seated in a booster seat that is restrained by a seat belt and secured on the rear seats.



## Warning

The upper belt must lay flat across the shoulder and chest, and never lay across the neck; the lower belt must lay flat across the pelvis, and never lay across the abdomen.

## Installing a Child Seat

Before installing a child seat, read the child seat manufacturer's instructions carefully and ensure that the seat can be installed in your vehicle. You can choose a child seat which is fastened with a seat belt or uses the ISOFIX system. The ISOFIX system is recommended.

- Installing a seat belt-restrained child seat  
To install a child seat on a rear seat, route the seat belt over the child seat, and buckle it up. Ensure that the belt is not twisted. Pull the belt tightly and remove all slack.



- Installing an ISOFIX child seat  
The rear outboard seats on your vehicle are both fitted with ISOFIX anchor points, which are located below the decorative curtain at the connection between the backrest and the cushion with ISOFIX marked. Open the decorative curtain, and slide the lower part of the child seat onto the ISOFIX anchor points.
  1. Lift the decorative curtain marked with ISOFIX, and slide the lower part of the child seat onto the seat's anchor bars until you hear it click into place.



2. Guide the upper tether strap on the child seat under the head restraint and towards the rear, and then fasten the belt to the anchor point located on the back of the rear seats.



3. Pull on the child seat to check if it fits snugly.

### Warning

- The ISOFIX attachment points are designed solely for child safety seats with the ISOFIX system. To avoid injury, never secure other objects to ISOFIX.
- Always follow the child safety seat manufacturer's instructions and this manual when installing and removing a child safety seat. Improper usage can result in injury to your child or other passengers.

## Multi Collision Braking (MCB)

Multi Collision Braking (MCB) comes standard on EL7. In certain types of collisions, the vehicle applies brakes to help prevent or mitigate a secondary collision. To help avoid or mitigate a secondary collision, the brakes are applied automatically to help brake the vehicle to stop. The brake lights and hazard warning lights will be activated and the latter will remain on after the vehicle has come to a standstill. The electrical parking brake will then be applied automatically.

In a situation where stopping the vehicle may not be desirable, you can override this operation by pressing the accelerator pedal.

This feature can only function when the braking system is sufficiently intact after the collision.

## Pet Mode

When the vehicle is put in Park, go to the Settings page from the control bar at the bottom of the central display, and tap **Comfortable Environment > Pet Mode** to turn on the pet mode. You can keep your pets in your vehicle for a while when necessary. After you lock your vehicle and leave, your vehicle will maintain an appropriate temperature to ensure the safety of your pets and vehicle. You can manually turn off the Pet Mode on the central display or in your mobile APP when necessary.

After you set the Pet Mode to ON, when you successfully lock your vehicle, the air conditioning air volume, the ventilation mode and the internal and external circulation will enter automatic mode (the temperature in your vehicle is 22 °C by default and can be manually set). The central display will display the cabin temperature and a prompt stating that pets have been intentionally left in the vehicle. The brightness of the instrument panel display **and HUD display** will be adjusted to the minimum, and the brightness of the central display will be adjusted to 50%. At this time, the NOMI voice wake-up function will be disabled, the window adjustment button will not be available, and the child safety lock will be activated for the rear doors and windows to ensure the safety of your pets and vehicle.

The Pet Mode is disabled by default before each drive, and once enabled, it can maintain the previous state even if the account is switched.

### Caution

- The Pet Mode is designed only for keeping pets in the vehicle temporarily. Do not leave children alone in the vehicle.
- The Pet Mode cannot be turned on along with the Keep Powered On Mode or Camp Mode.
- When the Pet Mode is turned on, the Guardian Mode and Remote Live View are temporarily unavailable. After the Pet Mode is turned off and the vehicle is locked, the Guardian Mode and Remote Live View are available again.
- When the Pet Mode is turned on, system upgrade or shifting is forbidden.
- The Pet Mode can only be turned on when the vehicle is in PARK and all doors are closed, but not in the Trailer/Wash Mode.
- When the Pet Mode is turned on, the NIO app will notify you that your pet is in the vehicle every two hours. You will be notified through a message when the remaining range is less than 60 km and the vehicle is not charging. When the



remaining range is less than 10 km, the Pet Mode will be automatically exited, and windows will be set to the Ajar position to keep the pet safe.

- When an exception occurs in the high voltage or climate control system, the Pet Mode will be automatically exited, and windows will be set to the Ajar position to keep the pet safe.

## Powered On Walk-away Mode

When the vehicle is put in Park, go to the Settings page from the control bar at the bottom of the central display, and tap **Amenity > Powered On Walk-away Mode** to turn on walk-away hold mode. When you need to leave the vehicle temporarily (such as when buying coffee or breakfast, etc.), you can keep the cabin in a comfortable state so that you can have a comfortable ride when you come back. You can manually turn off the Powered On Walk-away Mode on the central display or in the when needed.

When the Powered On Walk-away Mode is set, after you have locked up the vehicle, the air conditioning settings, seat heating, seat ventilation, seat massage and wiper status will all remain unchanged when you leave the vehicle. You can set up the duration for the Powered On Walk-away Mode and lighting. While the vehicle is in this mode, NOMI voice wake-up is disabled. After reaching the set duration time, it will be automatically disabled.

The Powered On Walk-away Mode is disabled by default before each drive, and once enabled, it can maintain the previous state even if the account is switched.

### Caution

- The Keep Powered On Mode is designed to maintain a comfortable climate in the vehicle when passengers leave the vehicle temporarily. Do not leave children or pets alone in the vehicle.
- The Keep Powered On Mode cannot be turned on along with the Pet Mode or Camp Mode.
- When the Keep Powered On Mode is turned on, the Guardian Mode and Remote Live View are temporarily unavailable. After the Keep Powered On Mode is turned off and the vehicle is locked, the Guardian Mode and Remote Live View are available again.
- The Keep Powered On Mode can only be turned on when the vehicle is in PARK, but not in the Trailer/Wash Mode.
- When the Keep Powered On Mode is turned on, system upgrade or shifting is forbidden.
- You will be notified through a message when the remaining range is less than 60 km and the vehicle is not charging. When the remaining range is less than 10 km, the Keep Powered On Mode will be automatically exited.

- When an exception occurs in the high voltage or climate control system, the Keep Powered On Mode will be automatically exited.

## Camping Mode

When the vehicle is put in Park, go to the Settings page from the control bar at the bottom of the central display, and tap **Comfortable Environment > Camping Mode** to turn on Camping Mode. When you need to use the power supply in your vehicle for a long time (such as for camping outdoors), you can have a safe and comfortable camping experience. You can manually turn off the Camping Mode on the central display or in your mobile APP when necessary.

After you set the Camping Mode to ON, the air conditioning will be turned on, the temperature in the front and rear rows will be 25 °C by default, the air circulation will be turned on, the air purification will be set to silent mode, all screens in your vehicle will be turned off according to the set screen off delay time, and the interior lights and doors and windows will be adjusted according to the options in the settings. At this time, the NOMI voice wake-up function is disabled.

The Camping Mode is disabled by default before each drive, and once enabled, it can maintain the previous state even if the account is switched.

### Caution



- The Camp Mode cannot be turned on along with the Pet Mode or Keep Powered On Mode.
- The Camp Mode can only be turned on when the vehicle is in PARK, but not in the Trailer/Wash Mode.
- When the Camp Mode is turned on, the Guardian Mode and Remote Live View are temporarily unavailable. After the Camp Mode is turned off and the vehicle is locked, the Guardian Mode and Remote Live View are available again.
- When the Camp Mode is turned on, system upgrade or shifting is forbidden. Walk Up Unlock and Walk-Away Lock are disabled temporarily and will be enabled again when the Camp Mode is exited. It is recommended to enable climate control to keep air circulation in this mode.
- You will be notified through a message when the remaining range is less than 60 km and the vehicle is not charging. When the remaining range is less than 10 km, the Camp Mode will be automatically exited, and windows will be set to the Ajar position.
- When the Camp Mode is turned on and the vehicle is locked from inside, if someone opens the door and leaves the vehicle, the center display will be lit up, and persons still in the vehicle will be notified that the vehicle is unlocked.

- When an exception occurs in the high voltage or climate control system, the Camp Mode will be automatically exited, and windows will be set to the Ajar position.

## Child Presence Detection (CPD)

As an auxiliary function for the safety of children, Child Presence Detection (CPD) can effectively remind users when children are left alone in the vehicle, and take corresponding early warning measures such as turning on the air conditioner, so as to protect the safety of the children to a certain extent and reduce the likelihood of incidents caused by users forgetting their children.

The camera and other sensors in the vehicle will detect the children after the user locks the vehicle. If the child is left alone in the vehicle, it will remind the user by means of double flashing lights, prompt tones and mobile APP messages, and upgrade the reminder if the user does not respond for a long time, and provide emergency assistance such as telephone notifications if necessary.

You can enable/disable this function in **Settings >Safety >Child Presence Detection (CPD)**. When this function is enabled, in the event of a hardware failure (including in-vehicle camera, millimeter-wave radar or air conditioner, etc.), the status icon will be displayed at the top of the central display , and corresponding prompts will be displayed when the icon is tapped; In the event that the camera is covered and other conditions, the status icon  will be displayed at the top of the central display, and corresponding prompts will be displayed when the icon is tapped.

### Caution

- As an auxiliary safety function, Child Presence Detection (CPD) is mainly used for detecting and reminding you that children have been left behind in the rear row. Since there is a possibility that it will fail to detect or mis-detect the presence of children, it cannot be solely used for child protection. It is not recommended that you leave children alone in your vehicle.
- Please return to the vehicle as soon as possible to take care of the children after receiving notifications via SMS or the mobile APP, so as to make sure that the children are safe in the vehicle.

## Front Collision Warning (FCW)

If the system judges that there is a potential collision risk with the vehicle, pedestrian or cyclist ahead, the Forward Collision Warning (FCW) will alert you with visual, auditory and tactile alarms.

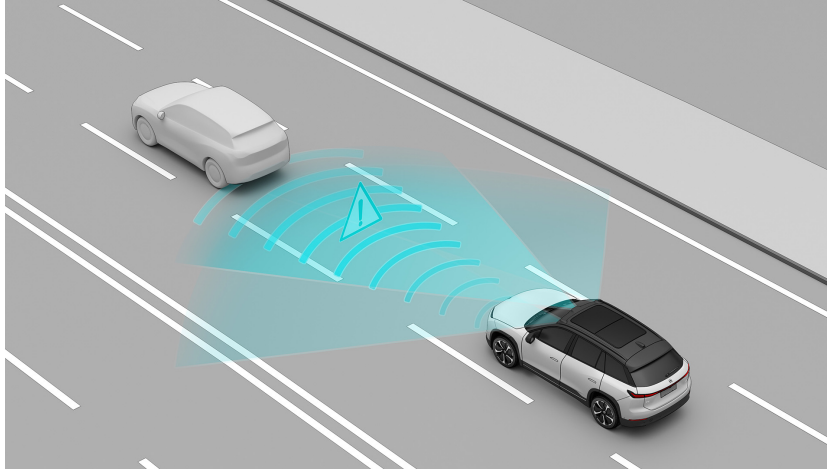

For vehicles, pedestrians or cyclists in front of you that are heading in the same direction, the Forward Collision Warning (FCW) system operates at speeds no less than about 4 km/h.

### Warning

- The forward collision warning is for reference only and cannot replace your attention and judgment.
- The forward collision warning is only applicable to the prevention of frontal collisions, and will not work when the vehicle is in reverse gear.
- As a driver assistance function, the forward collision warning can neither respond to all traffic, weather or road conditions, nor detect vehicles in all cases. It may become ineffective, inappropriate or untimely due to a number of factors.
- You must always pay attention to the traffic conditions and road environment. Do not rely on the judgment of the forward collision warning. Otherwise, personal or vehicle damage may occur.
- For safety reasons, do not intentionally drive towards vehicles to test the forward collision warning function. When danger is found, do not wait for the forward collision warning to trigger before taking action.
- If the risk of a collision further increases, Automatic Emergency Braking (AEB) will intervene regardless of whether the driver applies the brake or not.

- You always bear the ultimate responsibility for safe driving and shall abide by the current traffic laws and regulations.

Go to the Settings page from the control bar at the bottom of the central display, and tap **NIO Pilot >Forward Collision Warning (FCW)** to enable or disable this function.

Go to the Settings page from the control bar at the bottom of the central display, and tap **NIO Pilot >Warning Time** to set the warning time for this function.

Dynamic environment simulation displays image warnings when the Forward Collision Warning is triggered.

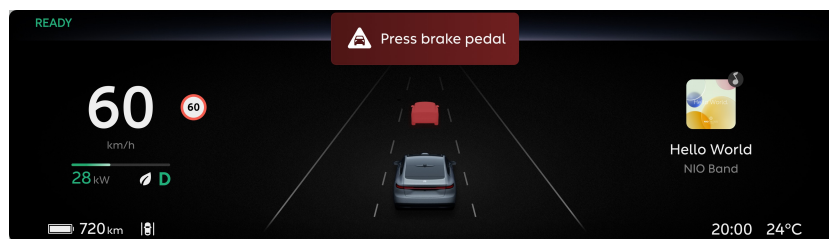

When the Forward Collision Warning is triggered, the vehicle will sound an auditory alarm reminding you to keep your distance from the vehicle ahead.

### Warning

When Forward Collision Warning is disabled, your vehicle will not warn you of a possible collision. It is not suggested to turn it off.

This feature will be turned on when the vehicle's system restarts.

### ***Precautions and Restrictions***

The following situations may lead to a camera recognition disorder and prevent the Forward Collision Warning from operating as expected. which include but are not limited to:

- Changed installation position of camera
- Blocked or dirty camera
- Reduced recognition capability due to dim surrounding environments, such as at dawn, dusk, night, or in a tunnel, etc..
- Sudden changes in ambient brightness, such as tunnel entrances or exits
- Large shadows cast by buildings, landscapes or large vehicles
- When the camera is slanted by the sun or exposed to direct sunlight.
- Severe weather such as rain, snow, fog, haze



- Exhaust gas, water spray, snow or dust lifted up by the vehicle ahead that falls onto your vehicle
- Water, dust, micro-scratches, oil sludge, dirt, wiper, ice, snow, etc. on the windshield in front of the camera
- Wet roads
- The camera is out of focus or faulty.

The following situations may lead to a laser radar recognition disorder and prevent the Forward Collision Warning from operating as expected. which include but are not limited to:

- Changed installation position of laser radar
- Severe weather such as rain, snow, fog, haze
- Exhaust gas, water spray, snow or dust lifted up by the vehicle ahead
- Driving on wet or waterlogged roads
- Water, dust, transparent vehicle coverings, color-changing film, micro-scratches, oil sludge, dirt, ice, snowfall and other obstructions on the laser radar window
- Overheating of the laser radar caused by prolonged sun exposure
- Due to the limitations of laser radar characteristics, in rare special cases, false alarms may occur for traffic signs and high-speed anti-collision barrels in high-speed and elevated sections of road.

Forward Collision Warning will only respond to vehicles that satisfy the conditions in the same direction. Some targets below will not trigger a response, which include but are not limited to:

- Animals
- Traffic lights
- Walls
- Barricades (cone barrels, etc.)
- Other non-vehicle objects

## Caution

- This feature cannot ensure that all special-shaped vehicles can be identified in all conditions. You need to pay extra attention, especially at night. Special-shaped vehicles may include tricycles, vehicles with a damaged taillight, unclear rear contour, or obstructed rear body, irregular-shaped vehicles, vehicles with a rear body lower than a certain height, or unloaded transporters for carrying vehicles.
- This feature may miss stationary or slow-moving vehicles, especially at night when the driver needs to pay extra attention.
- This feature may be falsely triggered when the vehicle needs to be driven onto special places such as a car hauler or a wrecker.

The following situations may prevent the Forward Collision Warning from operating as expected due to the fact that the target is not directly ahead, which include but are not limited to:

- It will not respond to targets in the blind spots of the sensor, such as targets in blind spots at corners, sides and back of the vehicle.
- It may wrongly select or miss targets when approaching or crossing a turn in the road.
- When going uphill, it may miss a target or misjudge the distance to the target.
- When only part of the body of a vehicle in the adjacent lane cuts in front of your vehicle (especially when it's a larger vehicle cutting in, like a bus, truck, etc.), it may not be able to recognize it in time.
- When your vehicle abruptly cuts into the rear of the vehicle ahead, or another vehicle abruptly cuts into or out of the front of your vehicle, it may not be able to recognize it in time.

The following situations may prevent the Forward Collision Warning from operating as expected due to special or complex road conditions, which include but are not limited to:

- Waterlogged roads, muddy roads, potholes, ice- and snow-covered roads, roads with speed bumps, roads with obstacles
- Traffic conditions with a lot of pedestrians, bicycles, battery vehicles or animals
- Complex and changeable traffic conditions, such as busy intersections, expressway ramps, congested roads
- Winding and turning roads, rapid turning roads

- Uphill and downhill roads
- Rough roads
- Tunnel entrances and exits

### **Warning**

Forward Collision Warning may not provide a warning in certain situations, including but not limited to:

- The driver is already applying the brakes.
- The driver fully or suddenly presses the accelerator pedal.
- The driver turns the steering wheel sharply.

### **Warning**

This feature is not recommended for use in bad weather conditions, including but not limited to heavy rain, snow, fog, and haze.

The above warnings, precautions and restrictions have not fully described all the conditions that may affect the normal operation of the Forward Collision Warning (FCW) system. There are many factors that may interfere with the Forward Collision Warning (FCW) system. In order to prevent accidents from occurring, you need to drive attentively and focus on the traffic, road, and vehicle conditions.

## Autonomous Emergency Brake (AEB)

If the system judges that the collision between the vehicle and the vehicle, pedestrian or cyclist in front of it is inevitable, it will actively apply emergency braking to try to reduce the driving speed, so as to reduce the impact of the rear-end collision as much as possible.

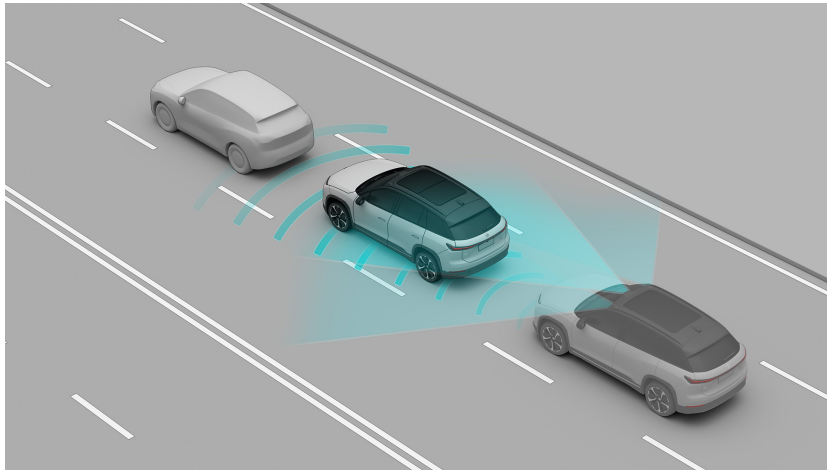

- For vehicles, pedestrians or cyclists in front of you, the Automatic Emergency Braking (AEB) system operates at speeds between about 4 and 150 km/h.
- For pedestrians at your rear, the Automatic Emergency Braking (AEB) system operates at speeds between about 4 and 15 km/h.

When the Automatic Emergency Braking is triggered, the vehicle's speed will be reduced by up to 60 km/h to mitigate a possible collision. For example, if the Automatic Emergency Braking is triggered at 90 km/h, the brake will be released when the speed drops to 30 km/h.

When the Automatic Emergency Braking is triggered, the dynamic environment simulation displays an image warning, and the brake pedal suddenly moves downward, turning on the brake light.

### Caution

The feature for detecting pedestrians behind the vehicle is still under optimization, which cannot ensure pedestrian detection in all conditions.

### Warning

As a driving assist feature, Autonomous Emergency Brake cannot handle all situations in all traffic, weather, and road conditions and cannot detect vehicles

in all situations. Several factors can cause an invalid, inappropriate, or untimely warning.

You must pay attention to the traffic and road conditions at all times. Never depend on Autonomous Emergency Brake to avoid collisions or reduce the impact of a collision. Doing so can cause personal injury or vehicle damage. For safety reasons, never test the use of Autonomous Emergency Brake when facing the direction of other vehicles, cyclists, or pedestrians. If you come across a dangerous situation, never wait for Autonomous Emergency Brake to intervene before taking action. You always bear the ultimate responsibility for driving safely and complying with applicable traffic laws and regulations.

### **Warning**

Autonomous Emergency Brake may apply short and sharp braking to reduce the risk of a potential collision, which may not be in line with your normal driving habit and may make you feel uncomfortable.

Go to the Settings page from the control bar at the bottom of the central display, and tap **NIO Pilot >Automatic Emergency Braking (AEB)** to enable or disable this function.

### **Warning**

When Autonomous Emergency Brake is disabled, your vehicle will not automatically apply the brakes even if a potential frontal collision is detected. It is not suggested to turn it off.

This feature will be turned on when the vehicle's system restarts.

### ***Precautions and Restrictions***

The following situations may lead to a camera recognition disorder and prevent the Automatic Emergency Braking from operating as expected. which include but are not limited to:

- Changed installation position of camera
- Blocked or dirty camera
- Reduced recognition capability due to dim surrounding environments, such as at dawn, dusk, night, or in a tunnel, etc..
- Sudden changes in ambient brightness, such as tunnel entrances or exits
- Large shadows cast by buildings, landscapes or large vehicles

- When the camera is slanted by the sun or exposed to direct sunlight.
- Severe weather such as rain, snow, fog, haze
- Exhaust gas, water spray, snow or dust lifted up by the vehicle ahead that falls onto your vehicle
- Water, dust, micro-scratches, oil sludge, dirt, wiper, ice, snow, etc. on the windshield in front of the camera
- Wet roads
- The camera is out of focus or faulty.

The following situations may lead to a laser radar recognition disorder and prevent the Automatic Emergency Braking from operating as expected. which include but are not limited to:

- Changed installation position of laser radar
- Severe weather such as rain, snow, fog, haze
- Exhaust gas, water spray, snow or dust lifted up by the vehicle ahead
- Driving on wet or waterlogged roads
- Water, dust, transparent vehicle coverings, color-changing film, micro-scratches, oil sludge, dirt, ice, snowfall and other obstructions on the laser radar window
- Overheating of the laser radar caused by prolonged sun exposure
- Due to the limitations of laser radar characteristics, in rare special cases, false alarms may occur for traffic signs and high-speed anti-collision barrels in high-speed and elevated sections of road.

Automatic Emergency Braking will only respond to vehicles that satisfy the conditions in the same direction. Some targets below will not trigger a response, which include but are not limited to:

- Animals
- Traffic lights
- Walls
- Barricades (cone barrels, etc.)
- Other non-vehicle objects

## Caution

- This feature cannot ensure that all special-shaped vehicles can be identified in all conditions. You need to pay extra attention, especially at night. Special-shaped vehicles may include tricycles, vehicles with a damaged taillight, unclear rear contour, or obstructed rear body, irregular-shaped vehicles, vehicles with a rear body lower than a certain height, or unloaded transporters for carrying vehicles.
- This feature may miss stationary or slow-moving vehicles, especially at night when the driver needs to pay extra attention.
- This feature may be falsely triggered when the vehicle needs to be driven onto special places such as a car hauler or a wrecker.

Vehicle targets may prevent the Automatic Emergency Braking (AEB) from operating as expected in the following situations, which include but are not limited to:

- The Automatic Emergency Braking will not respond to targets in blind spots of the sensor, such as those in blind spots at the corners, sides and back of the vehicle.
- It may wrongly select or miss targets when approaching or crossing a turn in the road.
- When going uphill, it may miss a target or misjudge the distance to the target.
- When only part of the body of a vehicle in the adjacent lane cuts in front of your vehicle (especially when it's a larger vehicle cutting in, like a bus, truck, etc.), it may not be able to recognize it in time.
- When your vehicle abruptly cuts into the rear of the vehicle ahead, or another vehicle abruptly cuts into or out of the front of your vehicle, it may not be able to recognize it in time.
- When the vehicle ahead is positioned at a large angle to this vehicle, it may not be able to be recognized in time.
- When only part of the body of the vehicle ahead overlaps with this vehicle, that vehicle may not be recognized in time.
- Situations such as during the short amount of time after the power-on, when the vehicle is in the Park gear, and when the seat belt is unfastened, etc..

The following situations may affect the ability of Automatic Emergency Braking to mitigate collisions due to special or complex road conditions, which include but are not limited to:

- Waterlogged roads, muddy roads, potholes, ice- and snow-covered roads, roads with speed bumps, roads with obstacles
- Traffic conditions with a lot of pedestrians, bicycles, battery vehicles or animals
- Complex and changeable traffic conditions, such as busy intersections, expressway ramps, congested roads
- Winding and turning roads, rapid turning roads
- Uphill and downhill roads
- Rough roads
- Tunnel entrances and exits

### Caution

The braking distance increases on slippery roads. If Anti-Lock Braking System, Traction Control System, and Electronic Stability Program are triggered, the performance of Autonomous Emergency Brake in reducing the impact of a collision may be impaired.

### Warning

The brake pedal moves downward abruptly during autonomous braking events. Do not place any objects under the brake pedal. Doing so can impede the ability of the brake pedal to move freely.

### Warning

Autonomous Emergency Brake is not a substitute for maintaining a safe following distance between you and the vehicle in front. Do not stay too close to vehicles in front of you and avoid driving aggressively.

### Warning

Autonomous Emergency Brake is mainly designed to reduce the impact of frontal collisions.



**Warning**

Autonomous Emergency Brake may not apply the brakes or may stop applying the brakes in some situations, including but not limited to:

- The driver fully or suddenly presses the accelerator pedal.
- The driver turns the steering wheel sharply.
- The driver's seat belt is unbuckled.
- The driver's door is not closed.
- Autonomous Emergency Brake has been triggered and cannot be triggered again within roughly 30 seconds.
- No vehicle is detected in front of the vehicle.

**Warning**

This feature is not recommended for use in bad weather conditions, including but not limited to heavy rain, snow, fog, and haze.

The above warnings, precautions and restrictions have not fully described all the situations that may affect the normal operation of the Automatic Emergency Brake (AEB) system. There are many factors that may interfere with the Automatic Emergency Braking (AEB) system. In order to prevent accidents from occurring, you need to drive attentively and focus on the traffic, road, and vehicle conditions.

## Lane Keeping Assist (LKA)

When your vehicle deviates from the lane involuntarily or unconsciously, the Lane Keeping Assist (LKA) will briefly assist the driver to control the steering wheel to move the vehicle back into the lane, and provide visual, auditory, or steering wheel vibration alerts to the driver.

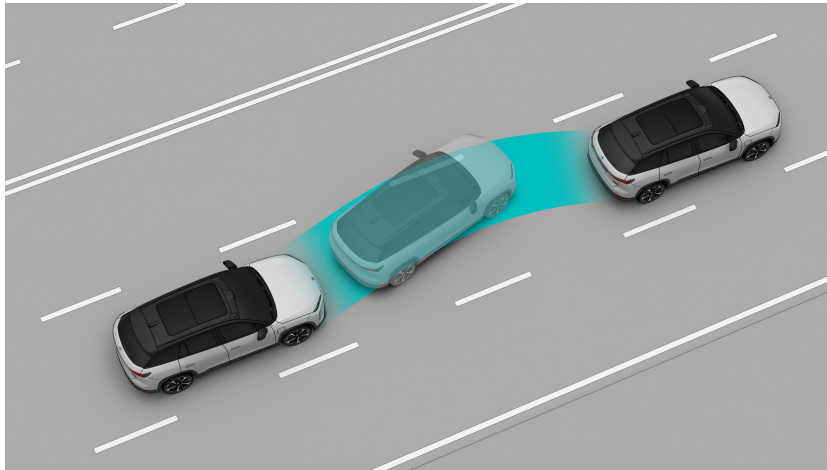

The Lane Keeping Assist (LKA) consists of:

- Alert only function (LDW): When the moving vehicle has a non-autonomous tendency to deviate to the adjacent lane, or is about to cross the lane marking, the Lane Departure Warning (LDW) can provide appropriate visual, auditory and steering wheel vibration alerts.
- Alert and lane correction: When the moving vehicle has a non-autonomous tendency to deviate to the adjacent lane, or is about to cross the lane marking, the Lane Keeping Assist (LKA) will apply a slight corrective Steer Assist to the steering wheel to reduce the possibility of the vehicle deviating from the lane. If the vehicle deviates too much from the lane, the Lane Keeping Assist (LKA) can provide appropriate visual and auditory alerts.

### Warning

Lane Keeping Assist can only provide limited steering assist and cannot control the vehicle's speed.

Lane Keeping Assist is unable to constantly control the steering. Therefore, it cannot always keep the vehicle centered in the lane.

## Warning

Lane Keeping Assist has limited steering torque which can only provide a slight steering assist and cannot fully guarantee the prevention of lane departure. Do not rely solely on Lane Keeping Assist to steer. You should always be prepared to take over steering, especially when driving on roads with curves.

Please take over steering immediately when cornering, turning around, or driving on winding roads or roads with sharp curves.

## Warning

As a driving assist feature, Lane Keeping Assist cannot handle all situations in all traffic, weather and road conditions.

Lane Keeping Assist is only a supplement to, and does not function as a substitute for, your visual observation. You must always pay attention to traffic and road conditions, and make your own decision on whether to use Lane Keeping Assist if it is safe.

You should always be ready to take over when you find that the conditions of the traffic, road or the vehicle are not suitable for enabling Lane Keeping Assist, or there are other unsafe factors.

You always bear the ultimate responsibility for driving safely in the lane and complying with applicable traffic laws and regulations.

## Warning

The following behaviors are prohibited when driving:

- Relying solely on Lane Keeping Assist
- Using Lane Keeping Assist in bad weather conditions
- Using Lane Keeping Assist on non-standardized roads
- Hands off the steering wheel
- Eyes off the road

### ***Enable/Disable the Lane Keeping Assist (LKA) system***

Go to the Settings page from the control bar at the bottom of the central display, and tap NIO Pilot >Lane Departure Warning (LDW) and Assist to enable or disable this function.

When enabled, you can select the assisting levels, alerting methods and sensitivity:

- Assisting level
  - Alert Only: only provides an alert function
  - Alert and Lane Correction: provides an alert and a slight Steer Assist
- Alert methods:
  - When it is set to Alert Only, the alert modes include: image, image + sound, image + vibration, image + sound + vibration.
  - When it is set to "Alert and lane correction", the alert methods cannot be set and the default option is image + sound.
- Sensitivity:
  - Low: gives an alert later than normal sensitivity under the same conditions
  - Medium: normal sensitivity
  - High: gives an alert earlier than normal sensitivity under the same conditions

### Caution

Please set the warning type and sensitivity with caution to ensure that such settings are in line with your driving habits.

### Caution

Enabling the Lane Departure Warning and Assist on the central display does not mean that the function has been activated. Functions can only be activated automatically when the operating conditions are satisfied.

When the Lane Departure Warning and Assistance function is disabled, the vehicle will neither assist when it comes to remaining in the driving lane, nor offer a warning when lane departure occurs. Emergency Lane Keeping (ELK) will be disabled too.

The steering wheel will turn when the Lane Departure Warning and Assistance function controls the direction.

You can turn the steering wheel to take control of the vehicle, and then the direction of the vehicle will be controlled by you.

Operating conditions for the Lane Keeping Assist (LKA) system:

- Your vehicle speed is about 65-130 km/h
- Your vehicle drives normally without suddenly accelerating, decelerating or steering.
- Your vehicle is in the center of its lane and does not drive on the lane marking
- The lane markings on at least one side are clear.
- The high-definition camera functions normally and provides clear vision
- No components of the Lane Keeping Assist system are faulty.
- Your vehicle meets all safety conditions, such as:
  - Driver seating status
  - Your vehicle is in gear position D
  - Anti-lock brake system, traction control system and vehicle stability control system are not triggered
  - The traction control system and vehicle stability control system are not manually disabled.

### Caution

When the turn signal is active, Lane Keeping Assist does not provide any reminders or take control if your vehicle deviates towards the corresponding side.

### ***Dynamic environment simulation display***

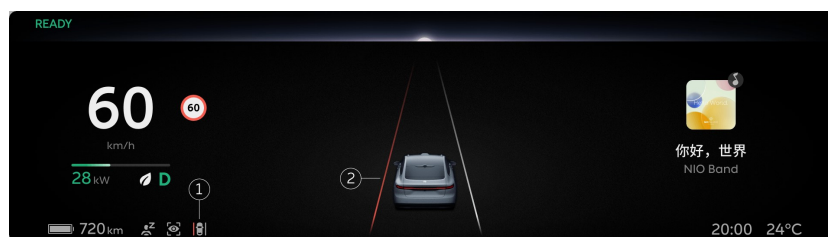

1. Status icon of the Lane Keeping Assist (LKA) system
  - No icon: Not enabled
  - Grey icon: Standby status

- White lane marking: The lane marking on the corresponding side has been detected.
- Yellow lane marking: Level 1 Lane Departure Warning
- Red lane marking: Level 2 Lane Departure Warning

## 2. Lane marking display

- No status icon: The Lane Keeping Assist (LKA) system is not enabled.
- The status icon is grey: The Lane Keeping Assist (LKA) system is enabled, in standby status, and not activated yet.

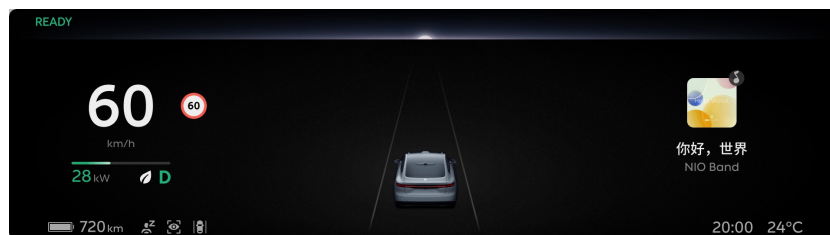

- The status icon and the central lane marking are white: The Lane Keeping Assist (LKA) system is active.

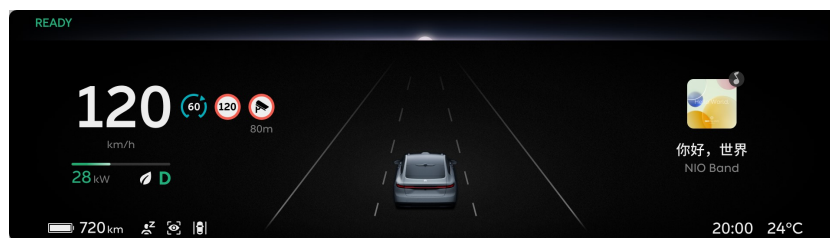

- The status icon and one side of the central lane marking is red:

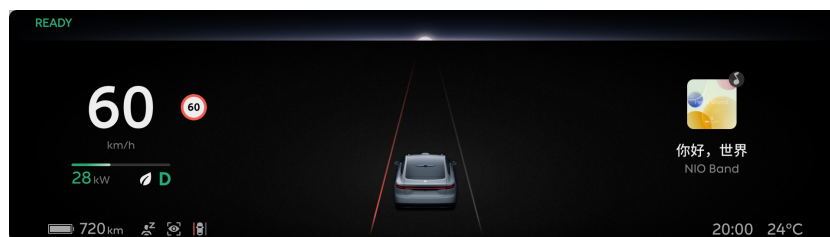

- When Alert Only is selected, it indicates that there is a risk of accidental departure from the lane on the corresponding side
- When Alert and Lane Correction is selected, it indicates that the vehicle has deviated from the lane unexpectedly, and the Lane Keeping Assist (LKA) is no longer able to prevent the vehicle from deviating from the lane through a slight Steer Assist to correct lanes.

- The status icon and one side of the central lane marking are yellow: Only occurs when Alert and Lane Correction is selected. It indicates that the Lane Keeping Assist (LKA) is providing a certain Steer Assist to correct lanes at the corresponding side to reduce the possibility of the vehicle deviating from the lane.

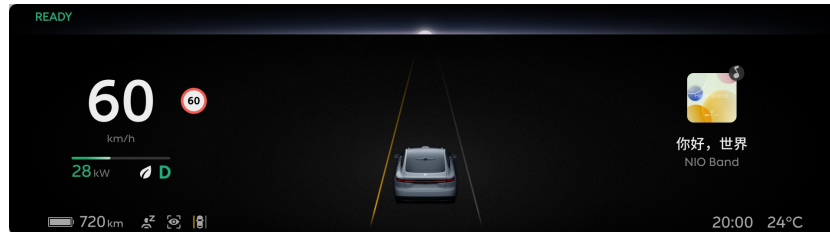

### Caution

The dynamic environment simulation display can only be used as a reference and cannot perfectly reflect the real traffic conditions. Therefore, do not rely on the dynamic environment simulation display.

### ***Precautions and Restrictions***

The following situations may prevent the Lane Keeping Assist (LKA) system from operating as expected or cause it to automatically exit, which include but are not limited to:

- Pass through bends with excessive curvature, such as high-speed ramps.
- The lane markings are not clear, worn, missing, interweaving, or shaded by other vehicles or buildings or scenery
- Passing through road sections without lane markings, such as non-standard roads, intersections and construction areas
- Passing through road sections with special lane markings, such as speed reduction markings and channelizing-line markings
- Passing through areas with unclear lane division, such as areas with merging or dividing lane markings, high-speed ramp crossings, urban intersection zones and left turn waiting zones
- There are edges or other high-contrast lines on roads instead of lane markings, such as pavement joints and curbs
- Lane markings cannot be recognized or are not recognized correctly due to height change, such as on the uphill and downhill

- Lane markings cannot be recognized or are not recognized correctly due to light, such as reflection of lane markings caused by strong light, poor visibility or insufficient light caused by bad weather and or at night
- The distance between lane markings on both sides is too wide or too narrow.

The following situations may prevent the Lane Keeping Assist (LKA) system from operating as expected or cause it to automatically exit due to a laser radar recognition disorder, which include but are not limited to:

- Changed installation position of camera
- Blocked or dirty camera
- Limited recognition at night
- Dark surroundings, such as at dawn, dusk, night, in tunnels
- Sudden changes in ambient brightness, such as tunnel entrances or exits
- Large shadows cast by buildings, landscapes or large vehicles
- Camera directly exposed to light
- Severe weather such as rain, snow, fog, haze
- Exhaust gas, water spray, snow or dust lifted up by the vehicle ahead that falls onto your vehicle
- Water, dust, micro-scratches, oil sludge, dirt, wiper, ice, snow, etc. on the windshield in front of the camera
- Wet roads

It is not recommended to use the Lane Keeping Assist (LKA) system in special or complex road conditions, as that may prevent the Lane Keeping Assist (LKA) system from operating as expected or cause it to automatically exit, which include but are not limited to:

- Waterlogged roads, muddy roads, potholes, ice- and snow-covered roads, roads with speed bumps, roads with obstacles
- Traffic conditions with a lot of pedestrians, bicycles or animals
- Complex and changeable traffic conditions, such as busy intersections, expressway ramps, congested roads
- Winding and turning roads, rapid turning roads
- Uphill and downhill roads
- Rough roads
- Narrow roads



- Tunnel entrances and exits
- Non-standard roads
- Roads without a median

### **Warning**

This feature is not recommended for use in bad weather conditions, including but not limited to heavy rain, snow, fog, and haze.

The above warnings, precautions and restrictions have not fully described all the conditions that may affect the normal operation of the Lane Keeping Assist (LKA) system. There are many factors that may interfere with the Lane Keeping Assist (LKA) system. In order to prevent accidents from occurring, you need to drive attentively and focus on the traffic, road, and vehicle conditions.

## Emergency Active Stop (EAS)

During driving, once the system detects that you are in an abnormal driving state (e.g., you are not holding the steering wheel for a period of time, you are distracted and fatigued for a period of time, or you are out of your seat), it will activate the Emergency Active Stop (EAS) feature when the normal operating conditions for the system are met.

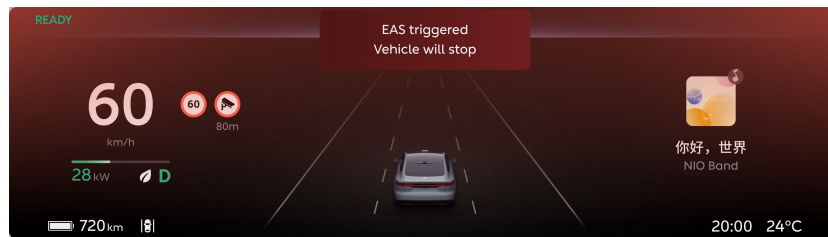

When Emergency Active Stop is activated, your vehicle will display a dynamic environment simulation warning message with audible and voice alerts, and turn on the hazard warning lights. The system will apply continuous braking with loud warning sounds to remind you to take over the vehicle until the vehicle stops. Then it will unlock the doors automatically and make an emergency call.

When Emergency Active Stop is activated, you can take over your vehicle anytime by pressing the accelerator pedal or brake pedal, rotating the steering wheel or turning off hazard warning lights.

### Warning

Once activated, the Emergency Active Stop feature will brake the vehicle until it stops, during which lane departure or collision may occur. Therefore, do not rely solely on or take the initiative to activate this feature.

By engaging the brakes and stopping the vehicle, the feature may lead to your violation of the Road Traffic Safety Law of the People's Republic of China, Regulation on the Implementation of the Road Traffic Safety Law of the People's Republic of China, and relevant traffic laws and regulations regarding temporary parking.

Please stay focused at all times while driving, as you always bear the ultimate responsibility for driving safely and complying with applicable traffic laws and regulations.

***Precautions and Restrictions***

Cameras may fail to recognize obstacles and thus impairing the performance of Emergency Active Stop in some situations, including but not limited to:

- The positions of the cameras are changed.
- The cameras are obstructed or stained.
- Visibility is poor in dim environments, such as at dawn, dusk, night, or in a tunnel, resulting in impaired recognition.
- Sudden changes in brightness, such as when entering or exiting a tunnel.
- The view of the cameras is interfered by large shadows cast by buildings, landscape features, or large vehicles.
- When the camera is directly struck by light.
- In rain, snow, fog, haze, and other bad weather.
- When exhaust gas, splashes, snow, or dust is kicked up by vehicles in front of you.
- The cameras are obstructed by water, dust, small scratches, grease, dirt, wipers, frost, or snow on the windshield.
- The road is wet.

Radars may fail to recognize obstacles and thus impairing the performance of Emergency Active Stop in some situations, including but not limited to:

- Radars are misplaced, blocked, or covered with dirt, ice, snow, metal plates, tape, labels, leaves, or other obstructions.
- Radars or the surrounding areas are damaged by collisions or scratches.
- Heavy rain, snow, fog, and other extreme weather which may impair radar performance
- False warnings may be generated due to certain metal fences, median strips or concrete walls.

The LiDAR sensor may fail to recognize obstacles, affecting the performance of or even causing the unintended deactivation of Emergency Active Stop in some situations, including but not limited to:

- The position of the LiDAR sensor is changed.
- In rain, snow, fog, haze, and other bad weather.
- The sensing performance is poor due to exhaust gas, splashes, snow, or dust kicked up by vehicles in front.

- The vehicle is driving on wet roads or roads with water.
- The LiDAR sensor is obstructed by water, dust, small scratches, grease, dirt, frost, snow, or wrap film / paint protection film on its window.
- The LiDAR sensor is too hot due to prolonged exposure of the vehicle to the sun.
- False warnings may be generated due to traffic signs and anti-collision buckets on expressways and elevated roads.

Emergency Active Stop will only respond to vehicles that meet certain conditions. Some targets may not be recognized or responded to, including but not limited to:

- Vehicles crossing perpendicular to your vehicle.
- Motorcycles and tricycles.

Some targets are not responded to, including but not limited to:

- Pedestrians.
- Bicycles.
- Animals.
- Traffic lights.
- Traffic cones.
- Walls.
- Barriers
- Vehicles crossing perpendicular to your vehicle.
- Oncoming vehicles
- Other non-vehicle objects

### Caution

- This feature does not guarantee the recognition of special-shaped targets, especially at night or a poor lighting environment where the driver needs to pay extra attention. Such vehicles include vehicles with a covered rear or irregularly-shaped rear, vehicles with a rear below a certain height, and unladen carriers.
- This feature may miss stationary or slow-moving vehicles, especially at night when the driver needs to pay extra attention.

Recognition and response may be delayed if the target is not right in the front in some situations, including but not limited to:

- Emergency Active Stop does not respond to targets that are in sensor blind spots. For example, Emergency Active Stop cannot detect targets in the blind spot at the corner or on the side of the vehicle.
- When the vehicle is approaching or navigating a curve, the target may be incorrectly selected or missed, resulting in unintended acceleration or deceleration.
- The target may be lost or the distance to the lead vehicle may be misjudged when the vehicle is on a slope. Driving downhill will increase the vehicle speed so as to exceed the cruise speed.
- When only a part of the vehicle in the adjacent lane cuts in front of you (especially large vehicles such as buses and trucks), the target may not be identified and trigger a response.
- When your vehicle suddenly cuts to the back of a vehicle in front, or when other vehicles abruptly cut into or out of the front of your vehicle, the target may not be identified in time.

Emergency Active Stop does not guarantee that the target can be accurately recognized in all situations, and its performance may be impaired in special or complex road conditions, including but not limited to:

- Water, mud, potholes, snow, ice, speed bumps, or obstacles on the road.
- Large numbers of pedestrians, bicycles, or animals on the road.
- Complex and changing traffic flows, such as busy intersections, freeway ramps, and congested roads.
- Winding roads and sharp turns.
- Uphill or downhill roads.
- Bumpy roads.
- Narrow roads.
- Tunnel entrances and exits.
- Non-standard roads.
- Roads without center medians.

Lateral grip may be insufficient in some situations, including but not limited to:

- The brakes do not fully function (such as when brake components are too cold, hot, or wet).
- Improper maintenance (such as excessive brake or tire wear, or abnormal tire pressure).
- Driving on special roads (such as sloping roads or roads with water, mud, potholes, snow, or ice).

### **Warning**

This feature is not recommended for use in bad weather conditions, including but not limited to heavy rain, snow, fog, and haze.

The above warnings, precautions and restrictions do not exhaust all the situations that may affect the proper operation of Emergency Active Stop. Emergency Active Stop may be affected by many factors. To avoid safety accidents, be sure to always pay attention to traffic, road and vehicle conditions and drive with caution.

## Emergency Lane Keeping (ELK)

Emergency Lane Keeping (ELK) can provide a certain steer assist capability to help the driver correct the vehicle position urgently to prevent the risk of collision as much as possible when the vehicle deviates from its lane involuntarily or when there is a potential side collision risk in its adjacent lane.

When the vehicle speed is about 65-130 km/h, Emergency Lane Keeping may be triggered in the following four emergency scenarios:

- Without turning signals, your vehicle deviates involuntarily from its lane to the right curb
- When the lane marking is a solid line, your vehicle deviates involuntarily from its lane to the side where the solid line is without having the turning signal on
- When there is an oncoming vehicle in your left lane, your vehicle deviates involuntarily from its lane without having the turning signal on
- When there is a vehicle approaching rapidly from behind in your left lane, your vehicle deviates from its lane or actively changes lane to the left

### ***Enable/disable Emergency Lane Keeping***

Go to the Settings page from the control bar at the bottom of the central display, and click **NIO Pilot > Emergency Lane Keeping** to turn this function on or off.

It is not recommended to turn off this function. When this function is turned off, it will not be able to assist the driver by taking emergency control of the steering when there is a potential risk of a side collision.

### **Warning**

Emergency Lane Keeping has limited steering torque which can only provide certain steering assist and cannot fully guarantee the prevention of lane departure or avoidance of danger. Therefore, please take over steering in time instead of relying solely on Emergency Lane Keeping.

Please control the vehicle direction immediately when cornering, turning around, or driving on winding roads or roads with sharp curves.

### **Warning**

As a driver assist feature, Emergency Lane Keeping cannot handle all situations in all traffic, weather and road conditions.

You must always pay attention to traffic and road conditions. Never rely solely on Emergency Lane Keeping to avoid danger. For safety reasons, never test this feature by deliberately or actively triggering Emergency Lane Keeping. If you come across a dangerous situation, never wait Emergency Lane Keeping to intervene before taking action. You always bear the ultimate responsibility for driving safely in the lane and complying with applicable traffic laws and regulations.

### Warning

The following behaviors are prohibited when driving:

- Relying solely on Emergency Lane Keeping
- Hands off the steering wheel
- Eyes off the road

### Operating Conditions of Emergency Lane Keeping:

- Your vehicle speed is about 65-130 km/h
- Your vehicle drives normally without sudden acceleration, deceleration or steering
- Your vehicle is in the center of its lane and does not drive on the lane marking
- The high-definition camera functions normally and provides clear vision
- No components of the Lane Keeping Assist system are faulty
- Your vehicle meets all safety conditions, such as:
  - Driver seating status
  - Your vehicle is in gear position D
  - Anti-lock brake system, traction control system and vehicle stability control system are not triggered

### Caution

Emergency Lane Keeping is automatically activated when the conditions are met in an emergency.

Emergency Lane Keeping can only provide limited steering assist and cannot control the vehicle's speed.

Emergency Lane Keeping is unable to constantly control the steering. Therefore, it cannot always keep the vehicle centered in the lane.



When Emergency Lane Keeping controls your steering, the steering wheel will turn accordingly.

You can take over steering by turning the steering wheel manually.

### ***Emergency Lane Keeping in Case of Deviation to Right Curb***

When the operating conditions of ELK are met, ELK can provide a certain degree of steer assist if your vehicle deviates from its lane involuntarily to the right curb without having the turning signal on. At this time, the right side of the central lane marking will be displayed in yellow.

### **Warning**

Emergency Lane Keeping may fail to operate as intended or cancel automatically and the vehicle may deviate to the right in some situations, including but not limited to:

- Curbs are not clear or cannot be or are incorrectly identified due to lighting conditions, such as strong light which leads to reflective curbs, and poor visibility or insufficient light due to bad weather or at night;
- There are roadside obstacles that Emergency Lane Keeping cannot identify, such as fences, guard rails, traffic cones and cone rods;
- The vehicle is steering around a sharp bend, or driving on a sloped road, bumpy road, road with water or snow and ice, etc.

### ***Emergency Lane Keeping in Case of Deviation to Solid Lane Marking***

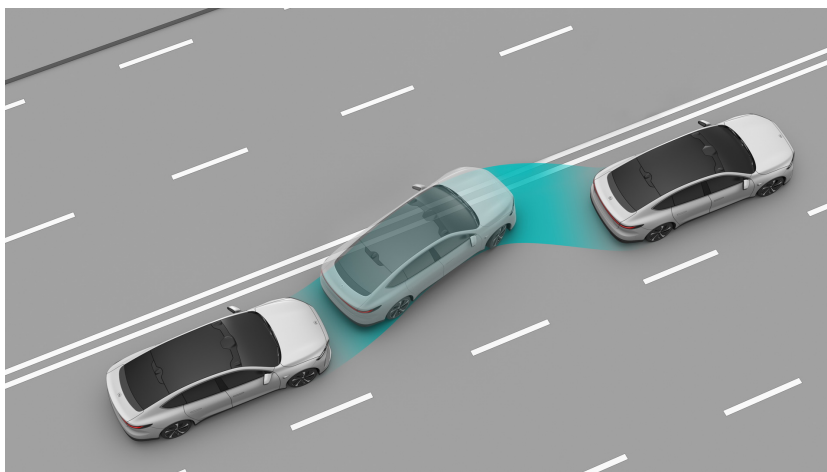

When the operating conditions of ELK are met, ELK can provide a certain degree of steer assist if your vehicle deviates from its lane involuntarily to the solid lane

marking without having the turning signal on. At this time, the corresponding side of the central lane marking will be displayed in red.

### Warning

Emergency Lane Keeping may fail to operate as intended or cancel automatically and the vehicle may deviate to the solid lane line in some situations, including but not limited to:

- Lane lines are unclear, worn, missing, overlapping, or obscured by shadows cast by other vehicles, buildings, or landscape features.
- The lanes are too wide or too narrow.
- Lane lines are special ones.
- Lane lines cannot be or are incorrectly identified due to changes in height, such as on sloped roads.
- Lane lines cannot be or are incorrectly identified due to lighting conditions, such as strong light which leads to reflective lane lines, and poor visibility or insufficient light due to bad weather or at night.
- The vehicle is steering around a sharp bend, or driving on a sloped road, bumpy road, road with water or snow and ice, etc.

### ***Emergency Lane Keeping with Risk of Left Front Collision***

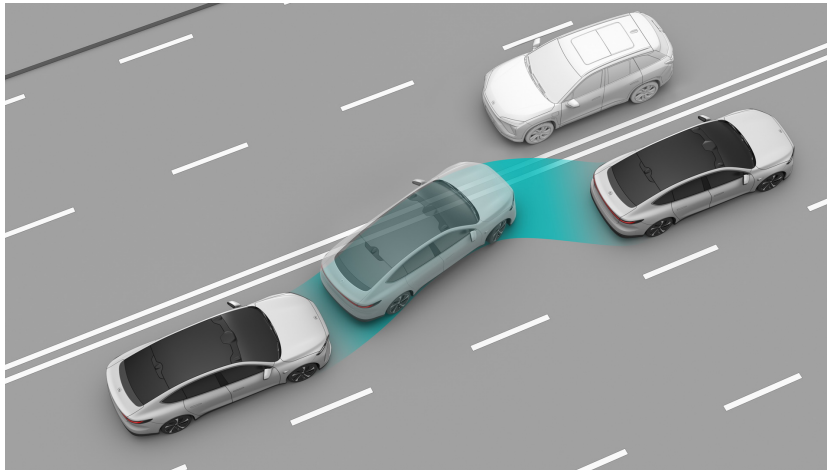

When the operating conditions of ELK are met, ELK can provide a certain degree of steer assist if your vehicle deviates from its lane involuntarily to the left without having the turning signal on when there is an oncoming vehicle in your left lane and the lane marking is clear. At this time, the left side of the central lane marking will be displayed in red.

**Warning**

Emergency Lane Keeping may fail to operate as intended or cancel automatically and the vehicle may collide with the lead vehicle on the left in some situations, including but not limited to:

- Lane lines are unclear, worn, missing, overlapping, or obscured by shadows cast by other vehicles, buildings, or landscape features.
- The lanes are too wide or too narrow.
- Lane lines are special ones.
- Lane lines cannot be or are incorrectly identified due to changes in height, such as on sloped roads.
- Lane lines cannot be or are incorrectly identified due to lighting conditions, such as strong light which leads to reflective lane lines, and poor visibility or insufficient light due to bad weather or at night.
- The vehicle is steering around a sharp bend, or driving on a sloped road, bumpy road, road with water or snow and ice, etc.
- The oncoming vehicle is not a vehicle, such as a motorcycle.

***Emergency Lane Keeping with Risk of Left Rear Collision***

When the operating conditions of ELK are met, ELK can provide a certain degree of steer assist if your vehicle deviates from its lane involuntarily or actively changes lane to the left when there is a vehicle approaching rapidly from behind in your left lane and the lane marking is clear. At this time, the left side of the central lane marking will be displayed in red.

**Warning**

Emergency Lane Keeping may fail to operate as intended or cancel automatically and the vehicle may collide with the vehicle approaching from behind on the left in some situations, including but not limited to:

- Lane lines are unclear, worn, missing, overlapping, or obscured by shadows cast by other vehicles, buildings, or landscape features.
- The lanes are too wide or too narrow.
- Lane lines are special ones.
- Lane lines cannot be or are incorrectly identified due to changes in height, such as on sloped roads.

- Lane lines cannot be or are incorrectly identified due to lighting conditions, such as strong light which leads to reflective lane lines, and poor visibility or insufficient light due to bad weather or at night.
- The vehicle is steering around a sharp bend, or driving on a sloped road, bumpy road, road with water or snow and ice, etc.

### ***Precautions and Restrictions***

The following situations may cause Emergency Lane Keeping to fail to operate as expected or exit automatically due to a camera recognition disorder. Please steer your vehicle in a timely manner. These situations include but are not limited to:

- Changed installation position of camera
- Blocked or dirty camera
- Reduced recognition capability due to dim surrounding environments, such as at dawn, dusk, night, or in a tunnel
- Sudden changes in ambient brightness, such as tunnel entrances or exits
- Large shadows cast by buildings, landscapes or large vehicles
- Camera directly exposed to light
- Severe weather such as rain, snow, fog, haze
- Exhaust gas, water spray, snow or dust lifted up by the vehicle ahead that falls onto your vehicle
- Water, dust, micro-scratches, oil sludge, dirt, wiper, ice, snow, etc. on the windshield in front of the camera
- Wet roads

The following situations may cause the emergency lane keeping to fail to operate as expected or exit automatically due to a radar recognition disorder. Please steer your vehicle in a timely manner. These situations include but are not limited to:

- Misplaced or blocked radar, or covered with mud, ice and snow, metal plates, tapes, labels, leaves, etc.
- The radar or the area surrounding it is impacted due to a vehicle collision, scratch, etc.
- Extreme weather such as rain, snow, fog, haze, which may affect radar performance

- Due to the limitation of radar target recognition characteristics, in rare special circumstances, false alarms may occur for some metal barriers, green belts, cement walls, etc.

The following situations may lead to a laser radar recognition disorder, affect the function of Emergency Lane Keeping, and even cause the function to deactivate. These situations include but are not limited to:

- Changed installation position of laser radar
- Severe weather such as rain, snow, fog, haze
- Exhaust gas, water spray, snow or dust lifted up by the vehicle ahead
- Driving on wet or waterlogged roads
- Obstructions such as water, dust, micro-scratches, oil sludge, dirt, wiper, ice, snow, tinted or transparent film on the laser radar window
- Overheating of the laser radar caused by prolonged sun exposure
- Due to the limitation of laser radar characteristics, in rare special cases, false alarms may occur for the traffic signs/high-speed anti-collision barrels in high-speed/elevated sections

Special or complex road conditions may cause the lane keeping assist system to fail to operate as expected or exit automatically. Please steer your vehicle in a timely manner. These situations include but are not limited to:

- Waterlogged roads, muddy roads, potholes, ice- and snow-covered roads, roads with speed bumps, roads with obstacles
- Traffic conditions with a lot of pedestrians, bicycles or animals
- Complex and changeable traffic conditions, such as busy intersections, expressway ramps, congested roads
- Winding and turning roads, rapid turning roads
- Uphill and downhill roads
- Rough roads
- Narrow roads
- Tunnel entrances and exits
- Construction areas

The above warnings, precautions and restrictions have not fully described all the situations that may affect the normal operation of the Emergency Lane Keeping

system. There are many factors that may interfere with the Emergency Lane Keeping system. In order to avoid accidents, you need to drive attentively and focus on the traffic, road, and vehicle conditions.

## Advanced Driver Monitoring System (ADMS)

The Advanced Driver Monitoring System (ADMS) can monitor the driver's driving status.

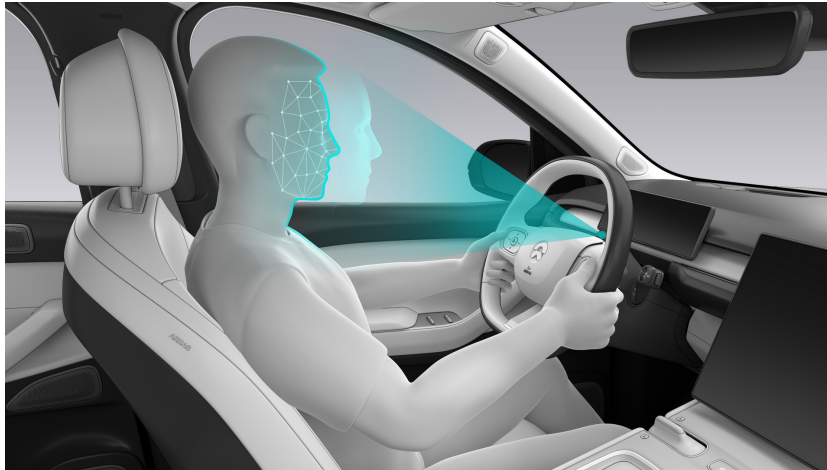

When it is enabled and conditions for activating the function are satisfied, once the driver is detected to be tired or distracted, NOMI will provide different levels of alerts through expressions and sounds. The digital instrument panel will also remind the driver to focus on driving and protect the driver's safety.

### Caution

Advanced Driver Monitoring System cannot operate under all conditions and is only designed to assist driving. The driver should always bear the ultimate responsibility for driving safely.

Therefore, it is of great importance that you pay attention when driving and take regular breaks. When a driver is alerted or feels fatigued, they should adjust their behavior or pull over safely as soon as possible to take a break.

When the Advanced Driver Monitoring System (ADMS) is disabled, related functions for advanced driving assistance systems such as Lane Centering Control (LCC) and Adaptive Cruise Control (ACC) will be unable to be used or will exit.

After the driver adjusts the steering wheel, the function requires a brief recalibration, during which the function fault light for the Advanced Driver Monitoring System (ADMS) will appear.

If you adjust the steering wheel while using the advanced driving assistance system functions such as Lane Centering Control (LCC) or Adaptive Cruise Control

(ACC), the system will prompt "NIO Pilot is exiting, please take control of the steering wheel".

### ***Enable/disable the Fatigue Distraction Alert System***

The Advanced Driver Monitoring System (ADMS) monitors the driver's fatigue and distraction state.

- Driver Fatigue Alert



- Driver Distraction Alert



Go to the Settings page from the control bar at the bottom of the central display, and tap **Driving>Driver Fatigue and Distraction Alert** to enable or disable this function.

After this function is enabled, when the vehicle speed is 20 km/h or above, the system will keep monitoring the status and provide voice alerts.

### ***Dynamic environment simulation display***

- Not enabled



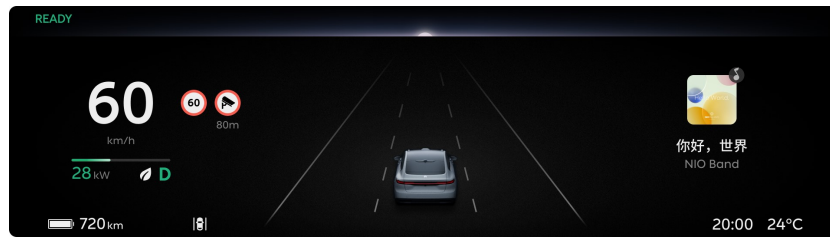

- Enabled

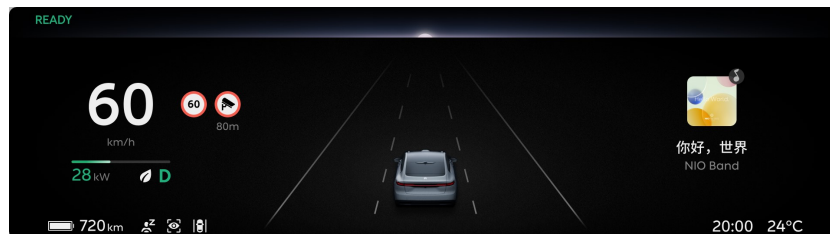

- Level 1 alarm (take the Driver distraction Alert function for example)
- Level 2 alarm (take the Driver distraction Alert function for example)
- If the driver still does not take control of the vehicle after a Level 2 alarm, the Emergency Active Stop (EAS) will be activated and triggered when the normal working conditions of the system are met.
- When the following displays due to a system failure or malicious occlusion of the camera, it indicates that the function is limited. Please promptly contact the NIO Service Center.

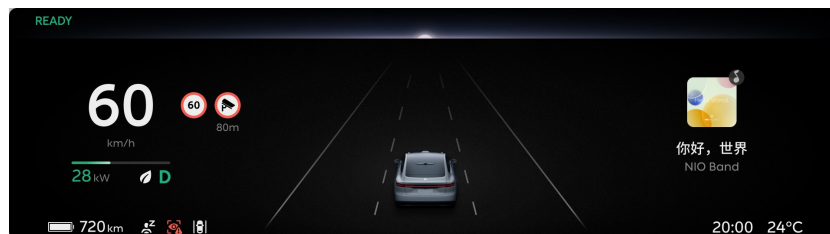

## Caution

The camera will not record or share any images, audio or videos.

## ***Precautions and Restrictions***

In some cases, driver fatigue and distracted driving behaviors may be undetected, resulting in the system not providing corresponding warnings, being partially unavailable or providing false alarms, such as:

- At night and in low light
- Sunlight, opposite headlights and other direct light interference

- Adjust the seat
- Adjust or turn the steering wheel
- Under the condition of eye occlusion, which includes but is not limited to various types of dark glasses with low transmittance, polarizers, sunglasses, and eyeglass frame occlusion, etc
- Wearing accessories such as hats, scarves and bandanas that may alter the shape of the head
- Wearing a mask

### **Warning**

This feature is not recommended for use in bad weather conditions, including but not limited to heavy rain, snow, fog, and haze.

The above warnings, precautions and restrictions have not fully described all the conditions that may affect the normal operation of the Advanced Driver Monitoring System (ADMS). There are many factors that may interfere with the Advanced Driver Monitoring System (ADMS). In order to prevent accidents from occurring, you need to drive attentively and focus on the traffic, road, and vehicle conditions.

## Blind Spot Detection (BSD) and Lane Change Assist (LCA)

The Blind Spot Detection (BSD) and Lane Change Assist (LCA) will remind you to pay attention to lane change safety through visual, auditory and tactile alarms when there are other vehicles in the blind spot of your vehicle or other vehicles approaching quickly in the blind spot.

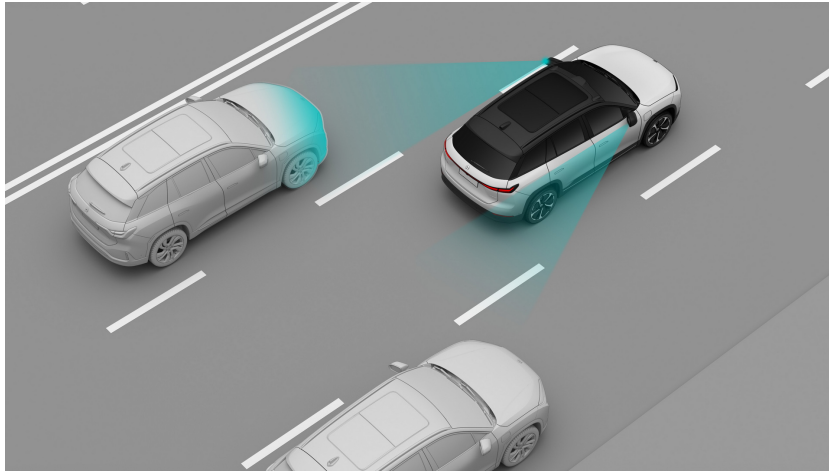

The Blind Spot Detection (BSD) and Lane Change Assist (LCA) will only be activated when the speed of your vehicle is about 15 km/h or more.

### Caution

This feature is able to detect the lanes next to the vehicle and more than 70 meters from the rear.

Go to the Settings page from the control bar at the bottom of the central display, and tap **NIO Pilot >Blind Spot Detection (BSD) and Lane Change Assist (LCA)** to enable or disable this function and select an appropriate means of reminding you.

When the function is enabled and activated, the dynamic environment simulation display will remind you that there is a vehicle approaching from behind as shown in the figure.

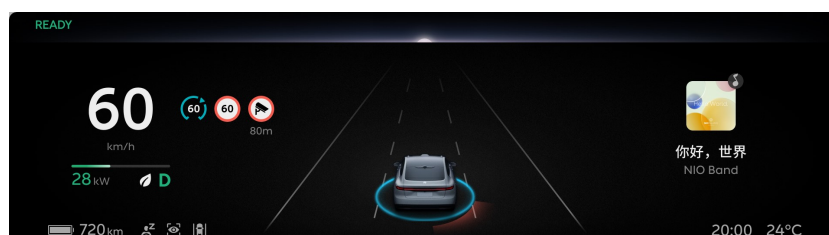

When a vehicle in the driver's blind spot and a vehicle approaching rapidly from behind are detected, a marker saying that there is a vehicle on the side will be displayed on the rear view mirror. If you turn on the turning signal on the corresponding side in this case, it will remind you not to change lanes with the following warnings:

- Marker light on the rear view mirror
- Sound + Marker light on the rear view mirror flashes
- Steering wheel vibrates + Marker light on the rear view mirror flashes
- Sound + Steering wheel vibrates + Marker light on the rear view mirror flashes

### Caution

The chime may not be heard if the environmental noise is too loud, such as when the audio system is played at high volumes or the surrounding environment is too noisy.

In a bright environment such as daytime, the warning of the red ambient lighting may not be easily noticeable.

### Caution

Blind Spot Detection and Lane Change Assist do not work when the vehicle is in REVERSE.

### Caution

The dynamic environment simulation display can only be used as a reference and cannot perfectly reflect the real traffic conditions. Therefore, do not rely on the dynamic environment simulation display.

### Caution

When you drive on a road with sharp curves, wide lanes or an uneven surface, Blind Spot Detection and Lane Change Assist may not be able to warn you about vehicles in adjacent lanes.

Blind Spot Detection and Lane Change Assist may give false warnings in the following situations:

- Driving near protective fences
- Driving on/under a bridge, or through a tunnel

- Driving besides bushes, trees, etc.
- When there are wire poles, street lights or low concrete walls along the road
- Driving near construction areas such as factory buildings, ports, etc.
- Driving on urban roads or multi-lane intersections

### Warning

- Radars are mounted on or behind the bumper. Keep the bumper clean and free of mud, ice, metal plates, stickers, labels, and leaves. Failure to do so may impact the performance of the radars.
- If this feature does not function properly due to a collision, scratches, radar failure, or malfunction, please contact NIO as soon as possible.
- If the radar malfunctions for a long period of time and fails to receive any fault-related alerts, please contact NIO as soon as possible.
- This feature only detects and alerts you to vehicles and large motorcycles or objects, and may have a delay or omission, or even fail to detect or alert you to objects such as pedestrians, bicycles, or skateboards.
- This feature does not alert you to stationary objects. False warnings may be generated by certain metal fences, median strips, or concrete walls.
- Heavy rain, snow, fog, and other extreme weather conditions may impair radar performance. Please drive with caution, and pay attention to your surroundings.
- Never use this feature in the Trailer Mode.
- You always bear the ultimate responsibility for driving safely and complying with applicable traffic safety laws and regulations.

### Warning

Even with Blind Spot Detection (BSD) and Lane Change Assist (LCA), you should still drive with caution and use the rearview mirror and the side mirrors wisely.

### Warning

This feature is not recommended for use in bad weather conditions, including but not limited to heavy rain, snow, fog, and haze.

The above warnings, precautions and restrictions have not fully described all the situations that may affect the normal operation of the Blind Spot Detection (BSD)

and Lane Change Assist (LCA) system. There are many factors that may interfere with the Blind Spot Detection (BSD) and Lane Change Assist (LCA) systems. In order to prevent accidents from occurring, you need to drive attentively and focus on the traffic, road, and vehicle conditions.

## Door Open Warning (DOW)

When you open the door of your vehicle, if vehicles, cyclists or pedestrians approaching from behind may affect the safety of opening the door or even cause a collision, the Door Open Warning (DOW) will remind you to be careful when opening the door through visual and auditory alarms.

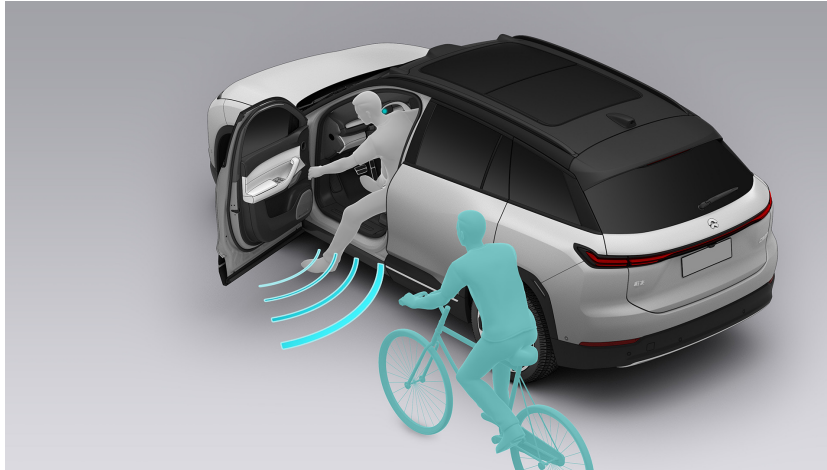

Go to the Settings page from the control bar at the bottom of the central display, and tap **NIO Pilot >Door Open Warning (DOW)** to enable or disable this function.

When the Door Open Warning (DOW) function is enabled, your vehicle will remind you in the following ways. At this time, you or your passengers should avoid opening the door and confirm whether it is safe to open the door first:

- The ambient light turns red
- Icon on the exterior rearview mirror
- Warning alarm
- Dynamic environment simulation displays "Watch out for vehicles approaching from behind"

### Note

Door Open Warning monitors for targets approaching fast from behind.

### Caution

This feature is only available when the vehicle is in DRIVE (D) or PARK (P).

**Caution**

The chime may not be heard if the environmental noise is too loud, such as when the audio system is played at high volumes or the surrounding environment is too noisy.

In a bright environment such as daytime, the warning of the red ambient lighting may not be easily noticeable.

**Warning**

Door Open Warning cannot accurately alert you in all situations and cannot replace active observation by you and passengers, as well as the function of the rearview mirror and side mirrors. Please do not rely excessively on this feature and always be aware of the environment outside the vehicle when opening doors.

**Warning**

- Radars are mounted on or behind the bumper. Keep the bumper clean and free of mud, ice, metal plates, stickers, labels, and leaves. Failure to do so may impact the performance of the radars.
- If this feature does not function properly due to a collision, scratches, radar failure, or malfunction, please contact NIO as soon as possible.
- If the radar malfunctions for a long period of time and fails to receive any fault-related alerts, please contact NIO as soon as possible.
- This feature only detects and alerts you to vehicles and large motorcycles or objects, and may have a delay or omission, or even fail to detect or alert you to objects such as pedestrians, bicycles, or skateboards.
- This feature does not alert you to stationary objects. False warnings may be generated by certain metal fences, median strips, or concrete walls.
- Heavy rain, snow, fog, and other extreme weather conditions may impair radar performance. Please drive with caution, and pay attention to your surroundings.
- Never use this feature in the Trailer Mode.
- You always bear the ultimate responsibility for driving safely and complying with applicable traffic safety laws and regulations.



**Warning**

This feature is not recommended for use in bad weather conditions, including but not limited to heavy rain, snow, fog, and haze.

The above warnings and precautions have not fully described all the conditions that may affect the normal operation of the Door Open Warning (DOW) system. There are many factors that may interfere with the Door Open Warning (DOW) system. In order to prevent accidents from occurring, you need to drive attentively and focus on the traffic, road, and vehicle conditions.

## Front Cross Traffic Alert

When driving at low speeds, if the system detects a potential collision risk with the rear crossing vehicle, the Front Cross Traffic Alert (FCTA) function can warn the driver to be careful through visual and auditory alerts.

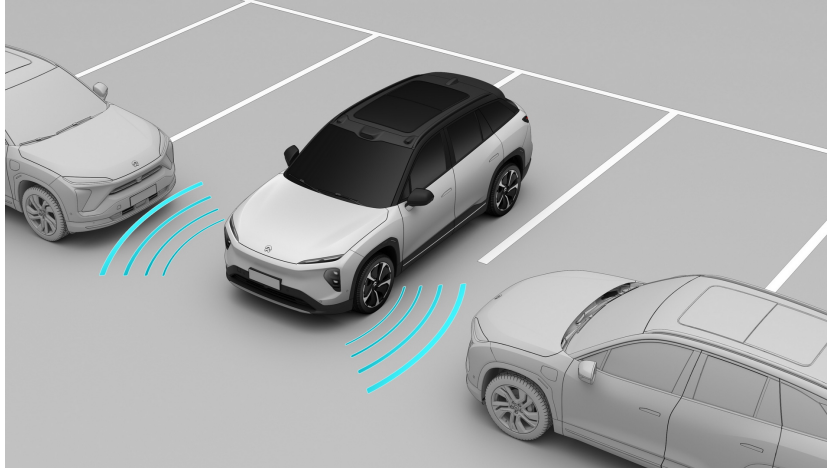

### Warning

Cross Traffic Alert is only a supplement to, and not a substitute for, your visual observation.

As a driver assist feature, Cross Traffic Alert cannot handle all situations in all traffic, weather and road conditions.

You must always pay attention to traffic and road conditions, and decide to use Cross Traffic Alert or not after your safety is ensured.

It is always your responsibility to ensure that the vehicle is driven in a safe manner and complies with applicable traffic laws and regulations.

### ***Enable/Disable the Front Cross Traffic Alert (FCTA)***

Go to the Settings page from the control bar at the bottom of the central display, and tap **NIO Pilot >Front Cross Traffic Alert (FCTA)** to enable or disable this function.

When the operating conditions are satisfied, if a potential collision risk with the front crossing vehicle is detected, it will remind you through visual and auditory alerts on the dynamic environment simulation display, 360 Surround View page and Automatic Parking page.

Operating conditions for the Front Cross Traffic Alert (FCTA)

- The vehicle speed is less than 15 km/h and greater than 0 km/h.
- The speed of the front crossing vehicle is within a certain range of the normal vehicle speed.
- The front lateral millimeter wave radar operates normally and has a clear field of view.
- Driver seating status
- Your vehicle is in gear position D

### Caution

The dynamic environment simulation display can only be used as a reference and cannot perfectly reflect the real traffic conditions. Therefore, do not rely on the dynamic environment simulation display.

### ***Precautions and Restrictions***

The targets below may not be identified, and may trigger a response, which include but are not limited to:

- Motorcycles
- Battery vehicles
- Tricycles
- Pedestrians
- Animals
- Bicycles
- Other non-vehicle objects

The targets below will not trigger a response, which include but are not limited to:

- Oncoming vehicles/vehicles driving in the same direction
- Stationary objects

The Front Cross Traffic Alert (FCTA) does not respond to targets in blind spots of the sensor. The Front Cross Traffic Alert (FCTA) cannot detect lateral vehicles in front of this vehicle through obstacles or parked vehicles.

For example, the Front Cross Traffic Alert (FCTA) cannot detect the front crossing vehicles in the following situations, which include but are not limited to:

- Stopping in the innermost position

- The parking space is at an angle.

The following situations may lead to a radar recognition disorder and affect the performance of the Front Cross Traffic Alert (FCTA), which include but are not limited to:

- Misplaced or blocked radar, or covered with mud, ice and snow, metal plates, tapes, labels, leaves, etc.
- The radar or the area surrounding it is impacted due to a vehicle collision, scratch, etc.
- Extreme weather such as rain, snow, fog, haze, which may affect radar performance
- Due to the limitation of radar target recognition characteristics, in rare special circumstances, false alarms may occur for some metal barriers, green belts, cement walls, etc.

### **Warning**

This feature is not recommended for use in bad weather conditions, including but not limited to heavy rain, snow, fog, and haze.

The above warnings, precautions and restrictions have not fully described all the conditions that may affect the normal operation of the Front Cross Traffic Alert (FCTA) system. There are many factors that may interfere with the Front Cross Traffic Assist (FCTA) system. In order to prevent accidents from occurring, you need to drive attentively and focus on the traffic, road, and vehicle conditions.

## Rear Cross Traffic Alert with Braking (RCTA-B)

When reversing, if the system detects a potential collision risk with the rear crossing vehicle, the Rear Cross Traffic Alert with Braking (RCTA-B) function can warn the driver to pay attention to safety through visual and auditory alerts and even enhance the warning effect to the driver by braking briefly if necessary.

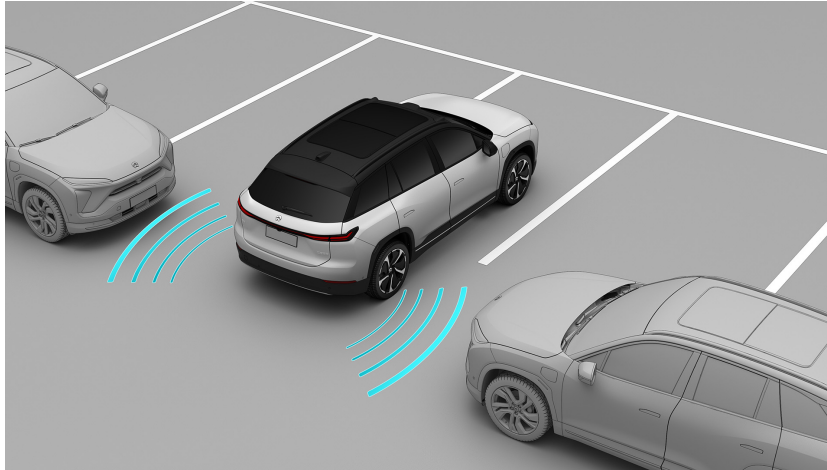

### Warning

Cross Traffic Alert is only a supplement to, and not a substitute for, your visual observation.

As a driver assist feature, Cross Traffic Alert cannot handle all situations in all traffic, weather and road conditions.

You must always pay attention to traffic and road conditions, and decide to use Cross Traffic Alert or not after your safety is ensured.

It is always your responsibility to ensure that the vehicle is driven in a safe manner and complies with applicable traffic laws and regulations.

### Warning

Never use this feature in the Trailer Mode.

### Warning

Rear Cross Traffic Alert only provides a warning and cannot guarantee to stop your vehicle. Never depend on it to avoid a collision or reduce the impact of a collision.

### **Enable/Disable the Rear Cross Traffic Alert with Braking (RCTA-B)**

Go to the Settings page from the control bar at the bottom of the central display, and tap NIO Pilot >Rear Cross Traffic Alert with Braking (RCTA-B) to enable or disable this function.

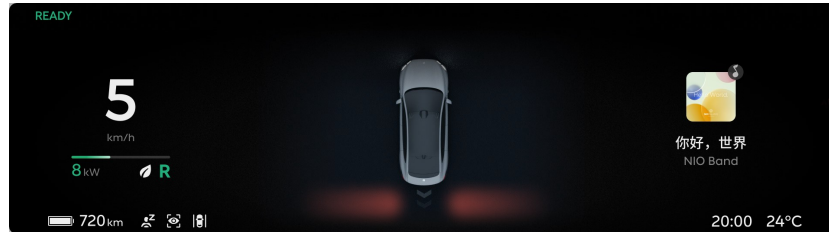

When it is enabled, you can select the assisting level in the Rear Cross Traffic Alert with Braking (RCTA-B) Settings:

- Alert only: when the vehicle speed is less than about 15km/h and the operating conditions are satisfied, if a potential collision risk with rear crossing vehicles from behind is detected, it will remind the vehicle in the rear through visual and auditory alerts on the digital instrument panel, 360 Surround View page and Automatic Parking page.
- Alert and brake actively: when the vehicle speed is about 1-15km/h and the operating conditions are satisfied, besides visual and auditory alerts, the system will warn you by a brief instance of active braking if necessary, but cannot ensure that the vehicle will stop.

Operating conditions for the Rear Cross Traffic Alert with Braking (RCTA-B):

- The speed of the rear crossing vehicle is between about 5 and 60 km/h.
- The rear lateral millimeter wave radar operates normally and has a clear field of view.
- Driver seating status
- All doors are closed
- Your vehicle is in gear position R.

### **Caution**

When you select Warning & Braking, if you fully press the brake pedal or accelerator pedal, the function may not intervene.

## Caution

The dynamic environment simulation display can only be used as a reference and cannot perfectly reflect the real traffic conditions. Therefore, do not rely on the dynamic environment simulation display.

### ***Precautions and Restrictions***

The targets below may not be identified, and may trigger a response, which include but are not limited to:

- Motorcycles
- Battery vehicles
- Tricycles
- Pedestrians
- Animals
- Bicycles
- Other non-vehicle objects

The targets below will not trigger a response, which include but are not limited to:

- Oncoming vehicles/vehicles driving in the same direction

The Rear Cross Traffic Alert with Braking (RCTA-B) does not respond to targets in blind spots of the sensor. The Rear Cross Traffic Alert with Braking (RCTA-B) cannot detect vehicles behind this vehicle through obstacles or parked vehicles.

For example, the Rear Cross Traffic Alert with Braking (RCTA-B) cannot detect rear crossing vehicles in the following situations, which include but are not limited to:

- Stopping in the innermost position
- The parking space is at an angle.

The following situations may lead to a radar recognition disorder and affect the performance of the Rear Cross Traffic Alert with Braking (RCTA-B), which include but are not limited to:

- Misplaced or blocked radar, or covered with mud, ice and snow, metal plates, tapes, labels, leaves, etc.
- The radar or the area surrounding it is impacted due to a vehicle collision, scratch, etc.

- Extreme weather such as rain, snow, fog, haze, which may affect radar performance
- Due to the limitation of radar target recognition characteristics, in rare special circumstances, false alarms may occur for some metal barriers, green belts, cement walls, etc.

### **Warning**

This feature is not recommended for use in bad weather conditions, including but not limited to heavy rain, snow, fog, and haze.

The above warnings, precautions and restrictions have not fully described all the conditions that may affect the normal operation of the Rear Cross Traffic Alert with Braking (RCTA-B) system. There are many factors that may interfere with the Rear Cross Traffic Alert (RCTA) and Assist System. In order to prevent accidents from occurring, you need to drive attentively and focus on the traffic, road, and vehicle conditions.



## Auto Lane Change (ALC)

The Auto Lane Change (ALC) adds a lane change assistance function on the basis of realizing Lane Centering Control (LCC). After enabling this function in Settings, the system will assist the vehicle to complete the lane change by toggling the turning signal lever when the environment and road conditions meet certain requirements.

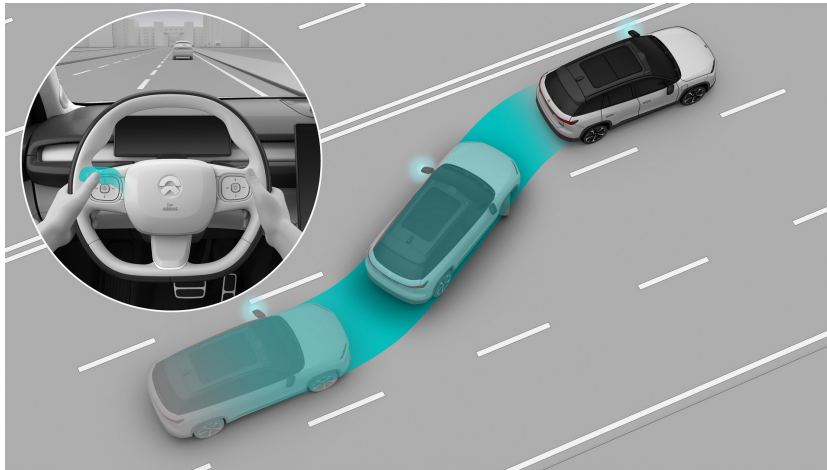

The Auto Lane Change (ALC) is applicable to high speed roads. The current and target lanes must be well lit, have clear lane markings and space to change lanes.

### Warning

As a driving assist feature, Active Lane Change cannot handle all situations in all traffic, weather, and road conditions.

You must always pay attention to traffic and road conditions and make your own decision on whether to use Active Lane Change if it is safe. You should always be ready to take over when you find that the conditions of the traffic, road, or the vehicle are not suitable for Active Lane Change, or there are other unsafe factors.

You always bear the ultimate responsibility for changing lanes safely and complying with current traffic laws and regulations.

### ***Enable/disable the Auto Lane Change (ALC)***

Go to the Settings page from the control bar at the bottom of the central display, and tap NIO Pilot >Auto Lane Change (ALC) to enable or disable this function.

Operating conditions for the Auto Lane Change (ALC):

- The driver's hands on the steering wheel
- The Lane Centering Control (LCC) is enabled and operating normally.

- The Auto Lane Change (ALC) is enabled and operating normally.
- The sensor functions properly and the field of view is clear.
- The vehicle speed is about 60-130 km/h.
- The current and target lanes meet all the safety conditions to change lanes. For example:
  - The lane marking on the side of the lane change is a dotted line.
  - The curvatures of the current and target lanes are small.
  - The vehicle maintains a safe distance between itself and vehicles in front of and behind it in the current and target lanes.
  - There is no Blind Spot Detection (BSD) and Lane Change Assist (LCA) and other alarms in the target lane.
  - The lane markings on both sides of the target lane are clear.
- None of the components for the Auto Lane Change (ALC) are faulty and the vehicle meets all safety conditions. For example:
  - No malfunction with the turning signal
  - Driver seating status
  - The driver has fastened his seat belt
  - All doors are closed
  - Your vehicle is in gear position D
  - The driver does not step on the brake pedal
  - Anti-lock brake system, traction control system and vehicle stability control system are not triggered

Enabling the Auto Lane Change (ALC) function in Settings does not mean that the function has been activated.

After meeting the operating conditions, you must perform a visual check to confirm the safety of the lane change environment, and then toggle the turning signal lever on the corresponding side. The system will detect if your hands are on the steering wheel.

- The system will activate the Auto Lane Change (ALC) function to assist the lane change if it detects that the conditions to change lanes have been met. At this time, the dynamic environment simulation will display the light band on the corresponding side turning blue and disappearing after a successful

lane change. After the lane change is completed, please confirm that the turning signal lever has been toggled back.

- The system will not perform the lane change if it detects that the conditions to change lanes has not been met and the dynamic environment simulation will display the light band on the corresponding side turning red.

Before or during a lane change, toggle the turning signal lever in the opposite direction of the lane change to cancel the lane change. When the following situations occur, the lane change will be interrupted, and you will be reminded through the digital instrument panel and sound alerts of the need to take control of your vehicle:

- The Auto Lane Change (ALC) detects an unsafe lane change environment, such as when the activation alarms for Blind Spot Detection (BSD) and Lane Change Assist (LCA) go off.
- Steer Assist is exited for reasons such as taking over the steering wheel control, unclear lane markings, and passing through excessively curved bends.
- Adaptive Cruise Control and Steer Assist are exited at the same time for reasons such as pressing the  button and depressing the brake pedal.

### Caution

Active Lane Change can only change one lane at a time.

### Caution

Assisted lane changes may fail if the light and visibility are poor at night, or when lane lines are not clear.

### Warning

Active Lane Change may suddenly be canceled due to unexpected circumstances. Please always pay attention to traffic and road conditions, and be prepared to take over at any time.

### Warning

You must always confirm if it is safe and appropriate before and when changing lanes. Please note that Active Lane Change cannot respond to pedestrians, obstacles, oncoming vehicles, etc. Never rely solely on Active Lane Change to

choose a driving path. You always bear the ultimate responsibility for changing lanes safely.

### ***Dynamic environment simulation display***

- Auto Lane Change (ALC) is making a lane change.

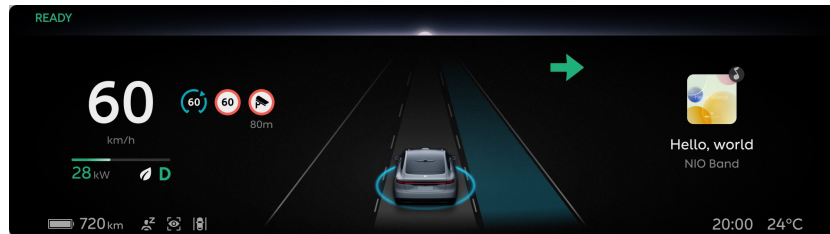

- Auto Lane Change (ALC) suspends or cannot make a lane change.

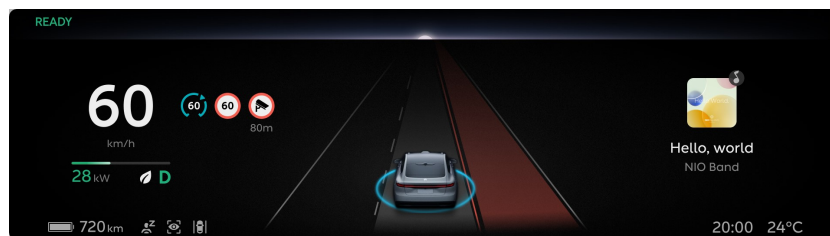

- Auto Lane Change (ALC) completes the lane change.

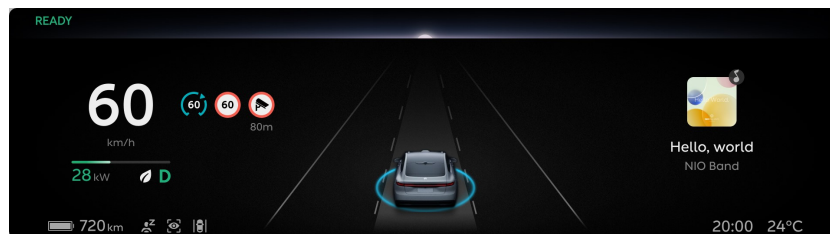

### **Caution**

The dynamic environment simulation display can only be used as a reference and cannot perfectly reflect the real traffic conditions. Therefore, do not rely on the dynamic environment simulation display.

### ***Precautions and Restrictions***

The following situations may prevent the Auto Lane Change (ALC) from completing the lane change or operating as expected, requiring the driver to take control of the steering wheel at any time, which include but are not limited to:

- Passing through bends with excessive curvature, such as high-speed ramps

- The lane markings of the current lane and target lane are not clear, worn, missing, crossed, or shaded by other vehicles or buildings or scenery
- Passing through road sections without lane markings, such as non-standard roads, intersections and construction areas
- Passing through areas with unclear lane division, such as areas with merging or dividing lane markings, high-speed ramp crossings, urban intersection zones and left turn waiting zones
- Passing through road sections with special lane markings, such as speed reduction markings and channelizing-line markings
- There are edges or other high-contrast lines on roads instead of lane markings, such as pavement joints and curbs
- Lane markings cannot be recognized or are not recognized correctly due to height change, such as on the uphill and downhill
- Lane markings cannot be recognized or are not recognized correctly due to light, such as reflection of lane markings caused by strong light, poor visibility or insufficient light caused by bad weather and or at night
- The distance between the lane markings on both sides of the current lane or the target lane is too wide or too narrow

The following situations may lead to a camera recognition disorder, thus making it impossible to complete the lane change assistance, which include but are not limited to:

- Changed installation position of camera
- Blocked or dirty camera
- Limited recognition at night
- Dark surroundings, such as at dawn, dusk, night, in tunnels
- Sudden changes in ambient brightness, such as tunnel entrances or exits
- Large shadows cast by buildings, landscapes or large vehicles
- Camera directly exposed to light
- Severe weather such as rain, snow, fog, haze
- Exhaust gas, water spray, snow or dust lifted up by the vehicle ahead that falls onto your vehicle
- Water, dust, micro-scratches, oil sludge, dirt, wiper, ice, snow, etc. on the windshield in front of the camera
- Wet roads

The following situations may lead to a radar recognition disorder, thus making it impossible to complete the lane change assistance, which include but are not limited to:

- Misplaced or blocked radar, or covered with mud, ice and snow, metal plates, tapes, labels, leaves, etc.
- The radar or the area surrounding it is impacted due to a vehicle collision, scratch, etc.
- Extreme weather such as rain, snow, fog, haze, which may affect radar performance
- Due to the limitation of radar target recognition characteristics, in rare special circumstances, false alarms may occur for some metal barriers, green belts, cement walls, etc.

The following situations may lead to a laser radar recognition disorder, affect the function of lane change assistance, and even cause the function to deactivate, which include but are not limited to:

- Changed installation position of laser radar
- Severe weather such as rain, snow, fog, haze
- Exhaust gas, water spray, snow or dust lifted up by the vehicle ahead
- Driving on wet or waterlogged roads
- Obstructions such as water, dust, micro-scratches, oil sludge, dirt, wiper, ice, snow, tinted or transparent film on the laser radar window
- Overheating of the laser radar caused by prolonged sun exposure
- Due to the limitation of laser radar characteristics, in rare special cases, false alarms may occur for the traffic signs/high-speed anti-collision barrels in high-speed/elevated sections

The Auto Lane Change (ALC) may leak or misdetect obstacles in the target and current lanes. You must always confirm whether it is safe and appropriate to change lanes before and during the lane change. The targets below may not be identified, and may trigger a response, which include but are not limited to:

- Side-crossing vehicles
- Motorcycles, tricycles

The targets below will not trigger a response, which include but are not limited to:

- Pedestrians
- Bicycles
- Animals
- Traffic lights
- Walls
- Roadblocks
- Oncoming vehicles
- Other non-vehicle objects

### Caution

- Active Lane Change cannot guarantee the recognition of special-shaped targets. Please pay extra attention, especially at night, to targets. Such vehicles include vehicles with a covered rear or irregular shape, vehicles with a rear below a certain height, and unladen carriers.
- Active Lane Change may miss stationary or slow-moving vehicles, especially at night when the driver needs to pay extra attention.

It is not recommended to use Auto Lane Change (ALC) in special or complex road conditions, which include but are not limited to:

- Waterlogged roads, muddy roads, potholes, ice- and snow-covered roads, roads with speed bumps, roads with obstacles
- Traffic conditions with a lot of pedestrians, bicycles or animals
- Complex and changeable traffic conditions, such as busy intersections, expressway ramps, congested roads
- Winding and turning roads, rapid turning roads
- Uphill and downhill roads
- Rough roads
- Narrow roads
- Tunnel entrances and exits
- Non-standard roads
- Roads without a median

**Warning**

This feature is not recommended for use in bad weather conditions, including but not limited to heavy rain, snow, fog, and haze.

The above warnings, precautions and restrictions have not fully described all the situations that may affect the normal operation of the Auto Lane Change (ALC) system. There are many factors that may interfere with the Auto Lane Change (ALC) system. In order to prevent accidents from occurring, you need to drive attentively and focus on the traffic, road, and vehicle conditions.



## Lane Centering Control (LCC)

Lane Centering Control provides the Steer Assist function to keep the vehicle in the lane on the basis of the vehicle speed control and distance maintenance functions under Adaptive Cruise Control. Lane Centering Control uses high-definition cameras, millimeter-wave radar and laser radar to detect vehicles ahead on the driving path, so as to actively control the speed of the vehicle and maintain the distance between itself and the vehicle ahead. Lane Centering Control uses high-definition cameras to identify lane markings as well. When the lane markings on both sides are clear, it can assist steering to keep the vehicle in the current lane.

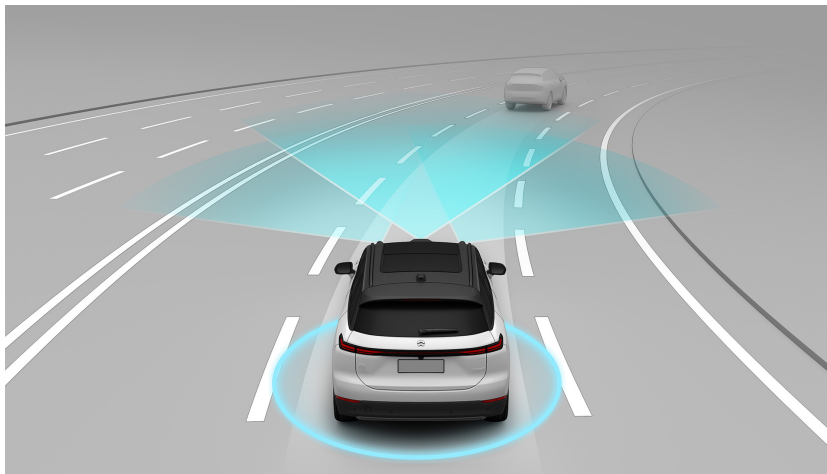

Lane Centering Control, as driving assistance, is unable to achieve NIO Pilot capabilities, so the driver shall keep both hands on the steering wheel and stay focused, ready to take control of the vehicle at any time.

Lane Centering Control is mainly for use on closed roads with clear lane markings and restricted access, such as expressways, elevated main roads or congested road sections.

### Caution

Lane Centering Control will strive to keep the vehicle in the lane when there are clear lane lines on both sides. Special road conditions and poor lighting on rainy days or at nighttime may result in impaired lane recognition, failure to keep the vehicle in the lane, or scratching. In this case, it is suggested that you temporarily turn off Lane Centering Control and switch to Adaptive Cruise Control.

**Warning**

As a driving assist feature, Lane Centering Control cannot handle all situations in all traffic, weather and road conditions.

You must always pay attention to traffic and road conditions, and decide to use Lane Centering Control or not after your safety is ensured.

You should always be ready to take over when you find that the conditions of the traffic, road or the vehicle are not suitable for enabling Lane Centering Control, or there are other unsafe factors.

You always bear the ultimate responsibility for maintaining an appropriate distance and speed and complying with applicable traffic laws and regulations.

**Warning**

The following behaviors are prohibited when driving:

- Relying solely on the system
- Using the feature in bad weather conditions
- Using the system in an environment where there are many pedestrians, bicycles, or animals
- Using the system on sharp curves
- Using the system when the lane lines are unclear or the lighting is poor
- Hands off the steering wheel
- Eyes off the road

**Warning**

As a feature for driving comfort, and not for preventing collision, Lane Centering Control has a limited maximum deceleration that is less than the maximum deceleration required by Automatic Emergency Brake and manual driving scenarios. Therefore, never rely solely on Lane Centering Control to decelerate the vehicle when avoiding a collision.

Lane Centering Control may fail to stop your vehicle or maintain a safe distance from the lead vehicle when the relative speed between your vehicle and the lead vehicle is great. In this case, exit Lane Centering Control immediately. Do not rely on Lane Centering Control to bring your vehicle to a complete stop regardless of whether it is following a stationary vehicle or a lead vehicle.

## Warning

Lane Centering Control has a limited steering torque that is less than the maximum steering force required in normal driving scenarios. Therefore, do not rely solely on Lane Centering Control to steer your vehicle. You should always be prepared to take over the steering, especially when navigating curves.

Please take over the steering immediately when cornering, turning around, and driving on winding roads or roads with sharp curves. Do not rely on Lane Centering Control in these situations due to limited visibility of lanes.

## ***Activating/deactivating Lane Centering Control***

Go to the Settings page from the control bar at the bottom of the central display, click **NIO Pilot > NIO Pilot Mode** and choose **Lane Centering** to turn this function on or off.

Turning on **Lane Centering** in the Settings does not mean that LLC is activated.



- Middle button: activates or deactivates Lane Centering Control
- Upper button: increase or resume the cruise speed
- Lower button: reduce the cruise speed
- Left button: reduce the following distance
- Right button: increase the following distance



1. Set cruising speed
2. Target vehicle ahead
3. Following time and distance
4. Status ring of Lane Centering Control
  - When the ring does not appear: Lane Centering Control is not activated, or the conditions for activation have not been met
  - When the ring is gray: Lane Centering Control is in standby and can be reactivated
  - When the ring is gray and flashing: Lane Centering Control is in Steer Assist standby, possesses the Adaptive Cruise Control functions and is now searching for lane markings
  - When the ring is blue with the lane highlighted in gray: Lane Centering Control is fully active and possesses the Adaptive Cruise Control and Steer Assist functions.

When the operating conditions are met, press the middle button  to activate Lane Centering Control.

- If the lane markings on both sides are clear and the vehicle is in the center of the current lane, activating Steer Assist will activate Adaptive Cruise Control as well.
- If the lane markings on both sides are unclear or the vehicle is not in the center of the current lane, it will first activate Adaptive Cruise Control and start searching for lane markings, and then activate Steer Assist when the conditions are met.

Lane Centering Control is available at a vehicle speed of 0-180 km/h, or 0-110 mph.

- If the vehicle speed is less than 30 km/h (20 mph), 30 km/h (20 mph) will be set as the cruise speed
- If the vehicle speed is higher than 30 km/h (20 mph) but not higher than 180 km/h (110 mph), the current vehicle speed will be set as the cruise speed

When Lane Centering Control activates Adaptive Cruise Control and starts searching for lane markings, you can release the accelerator pedal, and the system will maintain the set cruising speed.

- If there is a vehicle ahead, Lane Centering Control will adjust the speed of your vehicle according to the speed and distance of the vehicle ahead, and the maximum speed will not exceed the cruise speed
- When there is no vehicle ahead, Lane Centering Control will quickly adjust the speed of your vehicle to the cruise speed

When Lane Centering Control activates Steer Assist, it will actively assist with steering control, however, please keep your hands lightly on the steering wheel. The pressure of your hands may have a slight effect on the steering assist control, please pay close attention to the driving situation, and be ready to take control of the steering wheel at any time to control the direction of the vehicle.

The steering wheel turns when Lane Centering Control is controlling the steering. When Lane Centering Control is actively accelerating, the accelerator pedal does not move; when it's decelerating, the brake pedal may move.

#### **Working condition for Lane Centering Control:**

- The speed does not exceed 180 km/h or 110 mph
- High-definition cameras, millimeter-wave radar and laser radar functioning properly with a clear view
- No components of Lane Centering Control are faulty
- The function cannot be activated when the steering angle of the steering wheel is too large
- Your vehicle meets all safety conditions, such as:
  - The driver's hands on the steering wheel
  - Driver seating status
  - The driver has fastened his seat belt
  - All doors are closed
  - Your vehicle is in gear position D
  - The driver does not step on the brake pedal
  - Anti-lock brake system, traction control system and vehicle stability control system are not triggered

### ***To adjust the speed under Lane Centering Control***

When Lane Centering Control is active, go to the Settings page from the control bar at the bottom of the central display, tap **NIO Pilot > Cruising Speed Adjustment**, and select the appropriate way to adjust the cruising speed.

The cruising speed can be adjusted by:

- Short press to +1, long press to +5
  - Short press the Up or Down button on the left side of the steering wheel to increase/decrease the cruising speed by 1 km/h
  - Long press the Up or Down button on the left side of the steering wheel to increase/decrease the cruising speed to the closest 5 km/h increment, that is, if the speed is 82 km/h, long press the Up button on the left side of the steering wheel, and the speed will be increased to 85 km/h.
- Long press to +1, short press to +5
  - Long press the Up or Down button on the left side of the steering wheel to increase/decrease the cruising speed by 1 km/h
  - Short press the Up or Down button on the left side of the steering wheel to increase/decrease the cruising speed to the closest 5 km/h increment, that is, if the speed is 82 km/h, Short press the Up button on the left side of the steering wheel, and the speed will be increased to 85 km/h

The maximum set speed for Lane Centering Control is 180 km/h, or 110 mph.

The minimum set speed for Lane Centering Control is 30 km/h, but it allows the vehicle to decelerate to 0 km/h when following the vehicle ahead.

#### **Caution**

- To activate it for the first time, press and hold +1, or press shortly +5.
- The cruise speed cannot be adjusted via NOMI.

#### **Warning**

When driving with this feature on, if the system detects that you are not in a normal driving state (e.g., you are not holding the steering wheel for an extended period of time, you are distracted and fatigued for an extended period of time, or

you are out of your seat), it will activate Emergency Active Stop when the normal operating conditions for the system are met.

### ***To adjust the following time and speed under Lane Centering Control***

When the system is active or to be activated, the following time and distance can be adjusted in 5 settings.

- Press the right button on the left side of the steering wheel to set the following time and distance to a farther setting
- Press the left button on the left side of the steering wheel to set the following time and distance to a closer setting

### ***Takeover and Resume***

When driving with Lane Centering Control active, you can actively take control of the vehicle by stepping on the accelerator pedal or turning the steering wheel. Lane Centering Control will no longer respond to the target vehicle ahead when you actively take control by heavily stepping on the accelerator pedal.

Lane Centering Control will re-activate Adaptive Cruise Control as soon as you release the pedal.

Lane Centering Control and Steer Assist will retreat to the standby status for the time being when you actively take control by turning the steering wheel, but Adaptive Cruise Control will remain active and search for lane markings, during which time you will be controlling the direction of the vehicle.

When you stop turning the steering wheel, if the lane markings on both sides are clear and the vehicle is in the center of the current lane, Steer Assist will be automatically resumed.

After you exit Lane Centering Control by pressing  or depressing the brake pedal, you can activate it again by pressing the upper button on the left side of the steering wheel, and you can restore the vehicle's speed to the previously set cruise speed.

When Lane Centering Control stops the vehicle as the vehicle ahead stops, you can press the upper button on the left side of the steering wheel, or step on the accelerator pedal to restore the previously set cruising speed.

Reactivate Lane Centering Control, activate Adaptive Cruise Control first which will start searching for lane markings and, if the lane markings on both sides are clear and the vehicle is in the center of the current lane, activate Steer Assist.

### Caution

When Lane Centering Control is functioning properly:

- If Active Lane Change (ALC) is enabled in Settings and the required conditions are met, the vehicle will change lanes automatically when you toggle the turn signal lever. For more details, please refer to "Active Lane Change (ALC)" in the User Manual.
- If Active Lane Change (ALC) is not enabled in Settings, toggling the turn signal lever will put Steering Assist on standby, which requires you to take over the steering promptly. During this time, Adaptive Cruise Control will remain on and continue searching for lane lines. When the required conditions are met, Steering Assist will resume automatically.

### Caution

When Steering Assist functions properly and Active Lane Change (ALC) is not enabled in Settings, please take over the steering and exit Steering Assist if you need to change lanes.

### Warning

Steering Assist may fail to operate as intended in certain situations or disengage to standby while providing sound and text alerts to remind you to take over steering. During this time, Adaptive Cruise Control will remain on and continue searching for lane lines. When the required conditions are met, Steering Assist will resume automatically, including but not limited to:

- The vehicle is navigating sharp curves, such as on expressway ramps.
- Lane lines are unclear, worn, missing, overlapping, or obscured by shadows cast by other vehicles, buildings, or landscape features.
- The road section has no lane lines, such as non-standard roads, intersections, or construction areas.
- The road section has special lane lines, such as deceleration lines or diversion lines.
- Lane lines are not clearly divided, such as lane lines merging or diverting, expressway ramps, urban intersections, left-turn waiting areas, etc.
- There are edges or other high-contrast lines on the road instead of lane lines, such as road joints or curbs.



- Lane lines cannot be or are incorrectly identified due to changes in height, such as on sloped roads.
- Lane lines cannot be or are incorrectly identified due to lighting conditions, such as strong light which leads to reflective lane lines, and poor visibility or insufficient light due to bad weather or at night.
- The lanes are too wide or too narrow.

### ***Deactivating Lane Centering Control***

Lane Centering Control will be deactivated, and will no longer be in active control of speed and direction, and alert you when:

- The steering wheel button  is pressed
- The brake pedal is depressed

In addition, when the working conditions are no longer met, Lane Centering Control will be automatically deactivated, and you should take control of the brake pedal, accelerator pedal and steering wheel immediately after that to take control of the speed and direction of the vehicle.

### ***Dynamic environment simulation display***

- Standby for Steer Assist has the Adaptive Cruise Control functions and will search for lane markings. You will be controlling the direction of the vehicle.

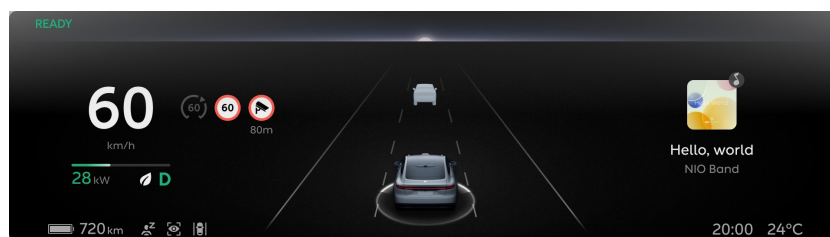

- Fully active, which has the Adaptive Cruise Control and Steer Assist functions.

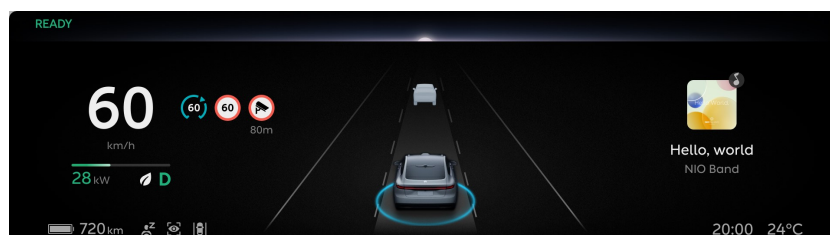

- Deactivated and returned to the standby state, when you can re-activate Lane Centering Control by pressing the button.

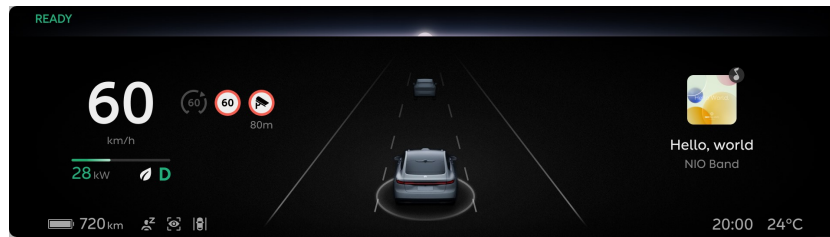

### Caution

The dynamic environment simulation display can only be used as a reference and cannot perfectly reflect the real traffic conditions. Therefore, do not rely on the dynamic environment simulation display.

### Caution

When neither lane line is clear, but there is a vehicle in front that meets requirements, your vehicle can follow the lead vehicle for a short time.

### Warning

When lane lines are unclear on both sides and your vehicle is following the lead vehicle, you may collide with other vehicles in adjacent lanes if the lead vehicle changes lanes at a slow speed. Therefore, you need to be prepared to take over at any time to ensure your safety.

Keep your hands on the steering wheel and eyes on the road ahead when driving with Lane Centering Control active.

- When the system detects that your hands have been off of the steering wheel and your eyes have been off of the road ahead for a period of time, dynamic environment simulation will display “Please keep your hands on the steering wheel” or “Please concentrate on driving”, and alert you audibly.
- When the system detects that your hands have been off the steering wheel and your eyes have been off of the road ahead for a period of time, dynamic environment simulation will display “Pilot is about to be deactivated, please put your hands on the steering wheel immediately”, or “Pilot is about to be deactivated, please take control of the vehicle immediately”, and keep alerting you audibly.
- When the system detects that your hands have been off the steering wheel and your eyes have been off of the road ahead for a period of time, dynamic environment simulation will display “Emergency Active Stop (EAS) is activated,

the vehicle is about to stop” and alert you audibly, accompanied by a NOMI voice prompt of “The vehicle is stopping” and double flashing lights.

When the system detects that your hands are on the steering wheel and your eyes are on the road ahead, the warning will disappear.

### ***Maintaining safe distance***

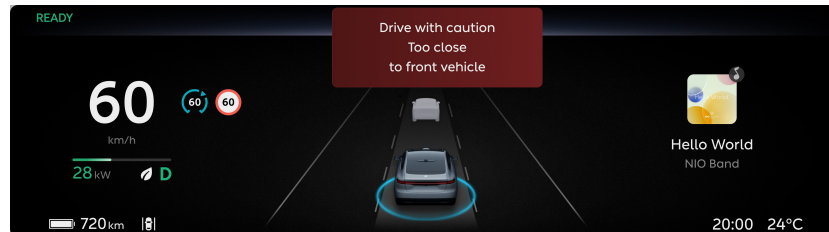

When dynamic environment simulation displays the “Please drive with caution, the distance to the vehicle ahead is too close” warning, it means that there is a risk of collision because the maximum deceleration available to Lane Centering Control can no longer maintain a safe distance, and you need to take control of the brake pedal and steering wheel immediately to take control of the speed and direction of the vehicle.

### **Warning**

If you encounter a dangerous situation, do not wait for a warning before taking action and take over immediately.

### ***Following Start/Stop***

When Lane Centering Control stops the vehicle as the vehicle ahead stops

- If the vehicle ahead starts, Lane Centering Control will follow it and actively start the vehicle as well. You need to pay attention to the surrounding environment at all times to prevent collision accidents from occurring;
- When the vehicle stops as the vehicle ahead stops for more than about 5 seconds, before it starts again to follow the vehicle ahead, it will alert you audibly;
- When the vehicle stops as the vehicle ahead stops for more than 5 seconds, and the system detects obstacles ahead that may affect driving, dynamic environment simulation will display “the vehicle ahead starts moving” prompt, and you need to re-activate Following Start by pressing the upper button on the left side of the steering wheel or stepping on the accelerator pedal after checking the surroundings;

- After approximately 5 minutes, Lane Centering Control will be deactivated and Electronic Parking will be activated instead.

After Lane Centering Control stops the vehicle as the vehicle ahead stops, it will start the vehicle again only when the distance to the vehicle ahead exceeds 4 meters.

### **Smart Speed Control**

Once activated, when the vehicle is driving on a highway or overpass under Lane Centering Control, it will alert you to change the speed limit when it detects a change in the road speed limit. You can manually confirm to keep the cruising speed consistent with the current road speed limit.

Go to the Settings page from the control bar at the bottom of the central display, and click **NIO Pilot > Smart Speed Control** to turn this function on or off.

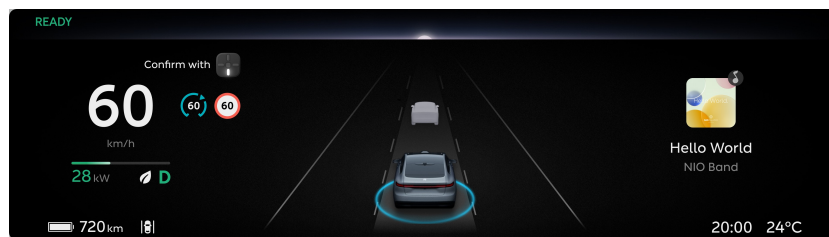

### **Warning**

Intelligent Speed Control is only a supplement to, and does not function as a substitute for, your visual observation. Never rely solely on the speed limit information recognized by Traffic Sign Recognition.

When the speed of the vehicle exceeds the speed limit of the road, you will be visually alerted of overspeed.

### **Warning**

- As a driving assist feature, Intelligent Speed Control cannot handle all situations in all traffic, weather and road conditions. You must always pay attention to traffic and road conditions, and make your own decision on whether to use Traffic Sign Recognition and Intelligent Speed Control if it is safe.
- Currently, Intelligent Speed Control does not work in complex road conditions such as ramps.

- You always bear the ultimate responsibility for driving safely and complying with applicable traffic laws and regulations.
- Intelligent Speed Control combines the speed limit information from the map to display the speed limit information on the digital instrument cluster. No speed limit information will be displayed when no speed limit information source is available from the map.

### Caution

The dynamic environment simulation display can only be used as a reference and cannot perfectly reflect the real traffic conditions. Therefore, do not rely on the dynamic environment simulation display.

### ***Precautions and Restrictions***

The following situations may cause the camera to identify obstacles, affect the performance of Lane Centering Control, or even cause deactivation, which include but are not limited to:

- Changed installation position of camera
- Blocked or dirty camera
- Limited recognition at night
- Dark surroundings, such as at dawn, dusk, night, in tunnels
- Sudden changes in ambient brightness, such as tunnel entrances or exits
- Large shadows cast by buildings, landscapes or large vehicles
- Camera directly exposed to light
- Severe weather such as rain, snow, fog, haze
- Exhaust gas, water spray, snow or dust lifted up by the vehicle ahead that falls onto your vehicle
- Water, dust, micro-scratches, oil sludge, dirt, wiper, ice, snow, etc. on the windshield in front of the camera
- Wet roads

The following situations may cause the millimeter-wave radar to identify obstacles, affect the performance of Lane Centering Control, or even cause deactivation, which include but are not limited to:

- Misplaced or blocked radar, or covered with mud, ice and snow, metal plates, tapes, labels, leaves, etc.

- The radar or the area surrounding it is impacted due to a vehicle collision, scratch, etc.
- Extreme weather such as heavy rain, snow, fog, which may affect radar performance
- Due to the limitation of radar target recognition characteristics, in rare special circumstances, false alarms may occur for some metal barriers, green belts, cement walls, etc.

The following situations may cause the laser radar to identify obstacles, affect the performance of Lane Centering Control, or even cause deactivation, which include but are not limited to:

- Changed installation position of laser radar
- Severe weather such as rain, snow, fog, haze
- Exhaust gas, water spray, snow or dust lifted up by the vehicle ahead
- Driving on wet or waterlogged roads
- Obstructions such as water, dust, micro-scratches, oil sludge, dirt, wiper, ice, snow, tinted or transparent film on the laser radar window
- Overheating of the laser radar caused by prolonged sun exposure
- Due to the limitation of laser radar characteristics, in rare special cases, false alarms may occur for the traffic signs/high-speed anti-collision barrels in high-speed/elevated sections

The vehicle will only respond to Lane Centering Control when the conditions are met. The targets below may not be identified, and may trigger a response, which include but are not limited to:

- Transverse vehicles
- Motorcycles, tricycles

The targets below will not trigger a response, which include but are not limited to:

- Pedestrians
- Bicycles
- Traffic cones
- Animals
- Traffic lights
- Walls

- Roadblocks
- Oncoming vehicles
- Other non-vehicle objects

The following situations may cause the late recognition and response of Lane Centering Control because the target is not directly ahead, which include but are not limited to:

- Lane Centering Control will not respond to targets in the sensor blind zone. For example, it cannot detect the blind spots at the corners of the vehicle and the blind spots on the sides of the vehicle.
- When approaching or turning along the road, some targets may be misselected or missed, resulting in the unexpected acceleration and deceleration of the vehicle.
- When going uphill, it may miss a target or misjudge the distance between itself and the vehicle ahead. When going downhill, it may accelerate the vehicle, causing it to exceed the cruising speed.
- When only part of the body of a vehicle in the adjacent lane cuts in front of your vehicle (especially when it's a larger vehicle cutting in, like a bus, truck, etc.), it may not be able to recognize the target in a responsive manner and require you to take control in time.
- When your vehicle abruptly cuts into the rear of the vehicle ahead, or another vehicle abruptly cuts into or out of the front of your vehicle, it may not be able to recognize the target in a responsive manner and require you to take control in time.

### Caution

- In rare cases, this feature may accelerate your vehicle even when it is not necessary or intended due to a change in, or loss of, the target (especially when cornering or changing lanes).
- In rare cases, this feature may apply the vehicle's brakes when it is not necessary or intended due to the detection of vehicles or objects, or a change in, or loss of, a stationary target in the adjacent lane (especially when cornering or changing lanes).
- When following the lead vehicle, if your vehicle or the lead vehicle switches out of the current lane, acceleration may be restricted by this feature for

a certain period of time for your safety. You can take over by pressing the accelerator pedal.

### Warning

This feature does not guarantee that the target can be accurately recognized in all situations. Please drive with caution and take over promptly if you find that the lane lines shown in the dynamic environment simulation do not match the actual situation. For example:

- A vehicle is in front of you, but the digital instrument cluster shows none.
- No vehicle is in front of you, but the digital instrument cluster shows a vehicle.

When driving in special or complex road conditions, it is not recommended to activate Lane Centering Control because it may affect the performance of Adaptive Cruise Control and Hold, or even cause deactivation, which include but are not limited to:

- Waterlogged roads, muddy roads, potholes, ice- and snow-covered roads, roads with speed bumps, roads with obstacles
- Traffic conditions with a lot of pedestrians, bicycles or animals
- Complex and changeable traffic conditions, such as busy intersections, expressway ramps, congested roads
- Winding and turning roads, rapid turning roads
- Uphill and downhill roads
- Rough roads
- Narrow roads
- Tunnel entrances and exits
- Non-standard roads
- Roads without a median

In the following situations, if the vehicle is driving too fast relative to the vehicle ahead, Lane Centering Control may be subject to limited control, which will result in an inability to maintain a safe distance in a responsive manner. which include but are not limited to:

- Sudden maneuvers of the vehicle ahead (such as sudden turns, acceleration, deceleration, etc.)
- Another vehicle abruptly cutting in or out of the front of your vehicle



- Your vehicle abruptly cutting in behind the vehicle ahead
- Your vehicle driving towards a stationary or slow-moving target at a high speed

It may not be able to provide sufficient braking force in the following situations, which include but are not limited to:

- The brake function cannot fully work (such as when brake parts are too cold, too hot, wet, etc.)
- Improper vehicle maintenance (excessive wear of the brake or tires, abnormal tire pressure, etc.)
- The vehicle is driving on special roads (such as uphill and downhill, water, mud, potholes, ice and snow roads, etc.)

### **Warning**

This feature is not recommended for use in bad weather conditions, including but not limited to heavy rain, snow, fog, and haze.

The above warnings, precautions and restrictions have not fully described all the situations that may affect the normal operation of the Lane Centering Control system. There are many factors that may interfere with the Lane Centering Control system. In order to prevent accidents from occurring, you need to drive attentively and focus on the traffic, road, and vehicle conditions.

## Adaptive Cruise Control (ACC)

Adaptive Cruise Control (ACC) can be used to sync your vehicle's speed automatically with the speed of the vehicle ahead. When there is no target in front of your vehicle to respond to, your vehicle will drive at the set speed. When there is a target to respond to, your vehicle will automatically change its speed to maintain the following distance you set.

Adaptive Cruise Control can only be used to control longitudinal speed and distance. This system includes the start and stop function of Adaptive Cruise Control, which allow your vehicle to follow the vehicle ahead till it stops (certain deceleration conditions need to be met). If the vehicle ahead drives away in a short amount of time, your vehicle can automatically start and follow. If the vehicle ahead remains stationary for a period of time, your vehicle will enter the parking state.

Adaptive Cruise Control is mainly applicable to long-distance driving on dry and smooth standardized straight roads, such as highways, expressways, and long straight roads.

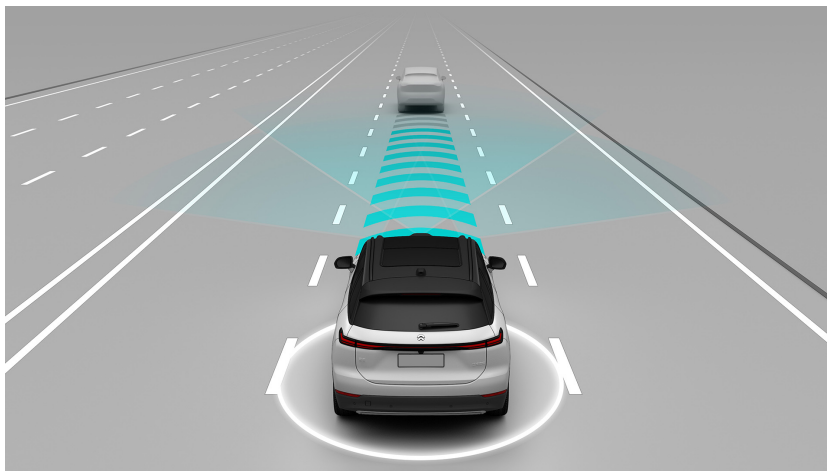

### Warning

As a driving assist feature, Intelligent Adaptive Cruise Control cannot handle all situations in all traffic, weather and road conditions.

Intelligent Adaptive Cruise Control controls the speed, but not the direction, of your vehicle.

You must always pay attention to traffic and road conditions, and make your own decision on whether to use Intelligent Adaptive Cruise Control if it is safe. You should always be ready to take over if you find that the conditions of the

traffic, road or the vehicle are not suitable for Intelligent Adaptive Cruise Control, or there are other unsafe factors. You always bear the ultimate responsibility for maintaining an appropriate distance and speed and complying with current traffic laws and regulations.

### **Warning**

The following behaviors are prohibited when driving:

- Relying solely on the system
- Using the feature in bad weather conditions
- Using the system in an environment where there are many pedestrians, bicycles, or animals
- Using the system on non-standardized roads, such as roads under construction or private roads
- Hands off the steering wheel
- Eyes off the road

### **Warning**

As a feature for driving comfort, and not for preventing collision, Intelligent Adaptive Cruise Control has a limited maximum deceleration that is less than the maximum deceleration required by Autonomous Emergency Brake and manual driving scenarios. Therefore, never rely solely on Intelligent Adaptive Cruise Control to decelerate the vehicle when avoiding a collision.

Intelligent Adaptive Cruise Control may fail to stop your vehicle or maintain a safe distance from the lead vehicle when the relative speed between your vehicle and the lead vehicle is great. In this case, press the brake pedal immediately for your safety. Do not rely on Adaptive Cruise Control to bring your vehicle to a full stop following the stationary vehicle or the lead vehicle in this situation.

## ***Activating Adaptive Cruise Control***



- Central button : activate or exit Adaptive Cruise Control
- Upper button: increase or resume the cruise speed
- Lower button: reduce the cruise speed
- Left button: reduce the following distance
- Right button: increase the following distance

When the operating conditions of Adaptive Cruise Control are met, press the central button on the left side of the steering wheel  to activate Adaptive Cruise Control.

Adaptive Cruise Control can be activated at the vehicle speed of 0-180 km/h (0-110 mph).

- If the vehicle speed is less than 30 km/h (20 mph), 30 km/h (20 mph) will be set as the cruise speed
- If the vehicle speed is higher than 30 km/h (20 mph) but not higher than 180 km/h (110 mph), the current vehicle speed will be set as the cruise speed

When Adaptive Cruise Control is activated, you can release the accelerator pedal to maintain the set cruise speed.

- If there is a vehicle ahead, Adaptive Cruise Control will adjust the speed of your vehicle according to the speed and distance of the vehicle ahead, and the maximum speed will not exceed the cruise speed
- When there is no vehicle ahead, Adaptive Cruise Control will quickly adjust the speed of your vehicle to the cruise speed

When driving by using Adaptive Cruise Control, you can depress the accelerator pedal hard at any time to take over your vehicle in a short amount of time. At this time, Adaptive Cruise Control will no longer respond to the target vehicle ahead, and your vehicle will be completely under your control. When you release the accelerator pedal, your vehicle will return to the cruising speed.

When Adaptive Cruise Control actively accelerates your vehicle, the accelerator pedal will not move. When Adaptive Cruise Control decelerates your vehicle, the brake pedal may move.

After you exit Adaptive Cruise Control by pressing the central button on the left side of the steering wheel  or depressing the brake pedal, you can activate it again by pressing the upper button on the left side of the steering wheel, and you can restore the vehicle's speed to the previously set cruise speed. If you press the upper button on the left side of the steering wheel while depressing the accelerator pedal, the current speed will be set as the cruise speed. The maximum set speed is 180 km/h (110 mph).

#### **Operating Conditions of Adaptive Cruise Control:**

- The high-definition camera, laser radar and millimeter wave radar function normally, and the field of vision is clear
- No components of Adaptive Cruise Control are faulty
- Your vehicle meets all safety conditions, such as:
  - Driver seating status
  - The driver's hands on the steering wheel
  - The driver has fastened his seat belt
  - All doors are closed
  - Your vehicle is in gear position D
  - The driver does not step on the brake pedal
  - Anti-lock brake system, traction control system and vehicle stability control system are not triggered
- The function cannot be activated when the steering angle of the steering wheel is too large
- The speed does not exceed 180 km/h or 110 mph

## Warning

When driving with this feature on, if the system detects that you are not in a normal driving state (e.g., you are not holding the steering wheel for an extended period of time, you are distracted and fatigued for an extended period of time, or you are out of your seat), it will activate Emergency Active Stop when the normal operating conditions for the system are met.

### ***Deactivating Adaptive Cruise Control***

Adaptive Cruise Control is deactivated when:

- The steering wheel button  is pressed
- The brake pedal is depressed

In addition, when the conditions for Adaptive Cruise Control are not met, it will be automatically deactivated. You can take control of the vehicle immediately after Adaptive Cruise Control is deactivated.

After Adaptive Cruise Control is deactivated, the vehicle may slow down due to regenerative braking, and will not be able to maintain the set distance between itself and the vehicle ahead.

## Warning

Intelligent Adaptive Cruise Control may be canceled suddenly due to unexpected circumstances. Please always pay attention to traffic and road conditions, and be prepared to take over at any time.

### ***Adjusting Vehicle Speed with Adaptive Cruise Control***

When Adaptive Cruise Control is active, go to the Settings page from the control bar at the bottom of the central display, tap **NIO Pilot > Cruising Speed Adjustment**, and select the appropriate way to adjust the cruising speed.

The cruising speed can be adjusted by:

- Short press to +1, long press to +5
  - Short press the Up or Down button on the left side of the steering wheel to increase/decrease the cruising speed by 1 km/h
  - Long press the Up or Down button on the left side of the steering wheel to increase/decrease the cruising speed to the closest 5 km/h increment, that

is, if the speed is 82 km/h, long press the Up button on the left side of the steering wheel, and the speed will be increased to 85 km/h.

- Long press to +1, short press to +5
  - Long press the Up or Down button on the left side of the steering wheel to increase/decrease the cruising speed by 1 km/h
  - Short press the Up or Down button on the left side of the steering wheel to increase/decrease the cruising speed to the closest 5 km/h increment, that is, if the speed is 82 km/h, short press the Up button on the left side of the steering wheel, and the speed will be increased to 85 km/h

The maximum set speed for Adaptive Cruise Control is 180 km/h, or 110 mph.

The minimum set speed for Adaptive Cruise Control is 30 km/h, but it allows the vehicle to decelerate to 0 km/h when following the vehicle ahead.

### Caution

- To activate it for the first time, press and hold +1, or press shortly +5.
- The cruise speed cannot be adjusted via NOMI.

### ***Adjusting Following Time and Distance with Adaptive Cruise Control***

When Adaptive Cruise Control is active or in standby, the following time and distance can be adjusted in 5 settings.

- Press the right button on the left side of the steering wheel to set the following time and distance to a farther setting
- Press the left button on the left side of the steering wheel to set the following time and distance to a closer setting

### Caution

When the time distance to the lead vehicle is set shorter, Intelligent Adaptive Cruise Control will respond more aggressively, which may cause a level of discomfort.

## Warning

It is your responsibility to determine and maintain a safe following distance at all times. Do not rely solely on Intelligent Adaptive Cruise Control to maintain an accurate or appropriate following distance.

### ***Dynamic environment simulation display***

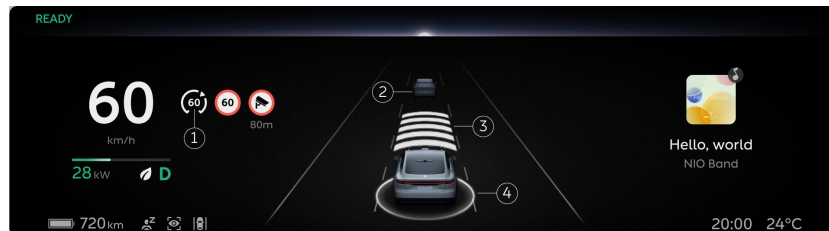

1. Set cruising speed
2. Target vehicle ahead
3. Following time and distance
4. Status ring of Adaptive Cruise Control
  - When the ring does not appear: Adaptive Cruise Control is not activated, or the conditions for activation are not met
  - When the ring is gray: Adaptive Cruise Control is in standby and can be reactivated
  - When the ring is white: Adaptive Cruise Control is active

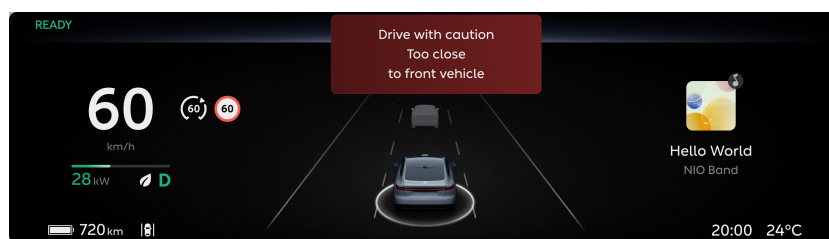

When the dynamic environment simulation displays the above warning, it means that there is a risk of collision because the maximum deceleration available to Adaptive Cruise Control can no longer maintain the safe distance, and you need to take control of the vehicle immediately.



**Caution**

The dynamic environment simulation display can only be used as a reference and cannot perfectly reflect the real traffic conditions. Therefore, do not rely on the dynamic environment simulation display.

**Warning**

If you encounter a dangerous situation, do not wait for a warning before taking action and take over immediately.

***Following Start/Stop***

When the vehicle stops when following the vehicle ahead under Adaptive Cruise Control

- If the vehicle ahead starts, Adaptive Cruise Control will follow it and actively start the vehicle as well. You need to pay attention to the surrounding environment at all times to prevent collision accidents from occurring;
- When the vehicle is stopped when following the vehicle ahead for no more than 5 minutes, starting while following is available under Adaptive Cruise Control;
- When the vehicle is stopped when following the vehicle ahead for over 5 minutes, Electronic Parking Brake (EPB) will be activated and Adaptive Cruise Control will be deactivated;
- If the system detects obstacles ahead that may affect driving, making it impossible to follow the vehicle ahead, you may, after checking the surroundings, reactivate Adaptive Cruise Control by stepping on the accelerator pedal

**Warning**

Intelligent Adaptive Cruise Control cannot detect other traffic participants in all situations, as this feature may fail, work improperly, or work with delay under the impact of multiple factors.

You must always pay attention to the traffic and road conditions. Never rely solely on Intelligent Adaptive Cruise Control to start the vehicle to follow, otherwise personal injury or vehicle damage may occur.

## Smart Speed Control

Once activated, when the vehicle is driving on a highway or overpass under Adaptive Cruise Control, it will alert you to change the speed limit when a change is detected in the road speed limit. You can manually confirm to keep the cruising speed consistent with the current road speed limit.

Go to the Settings page from the control bar at the bottom of the central display, and click **NIO Pilot > Smart Speed Control** to turn this function on or off.

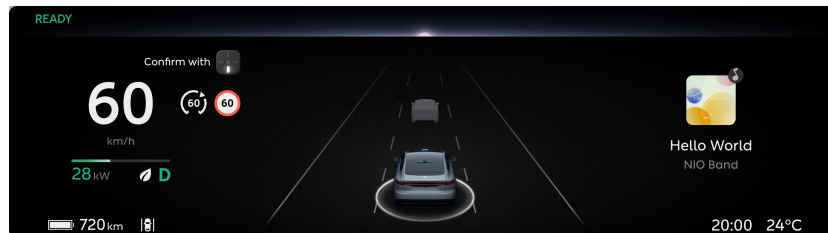

### Warning

Intelligent Speed Control is only a supplement to, and does not function as a substitute for, your visual observation. Never rely solely on the speed limit information recognized by Traffic Sign Recognition.

When the speed of the vehicle exceeds the speed limit of the road, you will be visually alerted of overspeed.

### Warning

- As a driving assist feature, Intelligent Speed Control cannot handle all situations in all traffic, weather and road conditions. You must always pay attention to traffic and road conditions, and make your own decision on whether to use Traffic Sign Recognition and Intelligent Speed Control if it is safe.
- Currently, Intelligent Speed Control does not work in complex road conditions such as ramps.
- You always bear the ultimate responsibility for driving safely and complying with applicable traffic laws and regulations.
- Intelligent Speed Control combines the speed limit information from the map to display the speed limit information on the digital instrument cluster. No speed limit information will be displayed when no speed limit information source is available from the map.

**Caution**

The dynamic environment simulation display can only be used as a reference and cannot perfectly reflect the real traffic conditions. Therefore, do not rely on the dynamic environment simulation display.

***Overtaking Assist provided by Adaptive Cruise Control***

When the vehicle is in following mode under Adaptive Cruise Control, if you turn on the left turning signal and steer the steering wheel in an attempt to overtake another vehicle, it will activate acceleration assist to accelerate up to the set cruising speed.

Overtaking Assist can be activated when:

- Adaptive Cruise Control is active and has detected a vehicle traveling in the same direction ahead
- The current vehicle speed is higher than 50 km/h, but not over the set cruising speed
- There is no lane marking or the lane marking is a dashed line on the side where the lane change is
- The vehicle is at a safe distance from the vehicle ahead
- The hazard warning light is not on
- No malfunction with the turning signal

When the above conditions are met, you can activate Overtaking Assist by moving the left turning signal lever to the bottom. When you turn the steering wheel to the left, Adaptive Cruise Control will maintain the distance between itself and the vehicle ahead, but will allow you to drive slightly closer than the set following distance. During a lane change, Adaptive Cruise Control will accelerate up to the set cruising speed without you stepping on the accelerator pedal.

**Caution**

Your vehicle may decelerate when Overtaking Assist is in operation due to the lead vehicle in the current or target lane, which is highlighted on the digital instrument cluster.

Overtaking Assist function will be deactivated, but Adaptive Cruise Control will remain active, when:

- A lane change is completed
- Overtaking Assist has been active for too long
- The turning signal lever is moved back before the lane change

### Caution

When the operating conditions for Intelligent Adaptive Cruise Control are not met, Overtaking Assist and Intelligent Adaptive Cruise Control will cancel.

### Caution

Overtaking Assist only assists in adjusting the vehicle's driving speed, and cannot control the steering. You must manually control the steering at all times.

### Caution

Overtaking Assist is unable to distinguish your intention to overtake from your intention to turn left.

### Warning

Overtaking Assist only detects the vehicle in front of you. In order to ensure your safety, you must pay attention to your surroundings before and during the process of overtaking.

### Warning

When using Overtaking Assist, you should be aware of the possibility of sudden acceleration or a lack of acceleration, and always be prepared to press or fully press the accelerator pedal to take over. Do not rely solely on this feature to overtake other vehicles.

### Warning

Overtaking Assist may fail to operate as intended in certain situations, including but not limited to:

- Approaching a left-hand exit
- Driving on winding roads
- The front vehicle's status in the current or target lane changes suddenly, e.g. sudden deceleration

- Obstacles to the side or rear of the vehicle

### ***Precautions and Restrictions***

The following situations may cause the camera to identify obstacles, affect the performance of Adaptive Cruise Control, or even cause deactivation, which include but are not limited to:

- Changed installation position of camera
- Blocked or dirty camera
- Reduced recognition capability due to dim surrounding environments, such as at dawn, dusk, night, or in a tunnel
- Sudden changes in ambient brightness, such as tunnel entrances or exits
- Large shadows cast by buildings, landscapes or large vehicles
- Camera directly exposed to light
- Severe weather such as rain, snow, fog, haze
- Exhaust gas, water spray, snow or dust lifted up by the vehicle ahead that falls onto your vehicle
- Water, dust, micro-scratches, oil sludge, dirt, wiper, ice, snow, etc. on the windshield in front of the camera
- Wet roads

The following situations may cause the laser radar to identify obstacles, affect the performance of Adaptive Cruise Control, or even cause deactivation, which include but are not limited to:

- Changed installation position of laser radar
- Severe weather such as rain, snow, fog, haze
- Exhaust gas, water spray, snow or dust lifted up by the vehicle ahead
- Driving on wet or waterlogged roads
- Water, dust, transparent vehicle coverings, color-changing film, micro-scratches, oil sludge, dirt, ice, snowfall and other obstructions on the laser radar window
- Overheating of the laser radar caused by prolonged sun exposure
- Due to the limitation of laser radar characteristics, in rare special cases, false alarms may occur for the traffic signs/high-speed anti-collision barrels in high-speed/elevated sections

The following situations may cause the radar to identify obstacles, affect the performance of Adaptive Cruise Control, or even cause deactivation, which include but are not limited to:

- Misplaced or blocked radar, or covered with mud, ice and snow, metal plates, tapes, labels, leaves, etc.
- The radar or the area surrounding it is impacted due to a vehicle collision, scratch, etc.
- Extreme weather such as heavy rain, snow, fog, which may affect radar performance
- Due to the limitation of radar target recognition characteristics, in rare special circumstances, false alarms may occur for some metal barriers, green belts, cement walls, etc.

The vehicle will only respond to Adaptive Cruise Control when the conditions are met. The targets below may not be identified, and may trigger a response, which include but are not limited to:

- Transverse vehicles
- Motorcycles, tricycles

The targets below will not trigger a response, which include but are not limited to:

- Pedestrians
- Animals
- Traffic lights
- Walls
- Roadblocks
- Oncoming vehicles
- Bicycles
- Other non-vehicle objects

### Caution

- This feature does not guarantee the recognition of special-shaped targets, especially at night or a poor lighting environment where the driver needs to pay extra attention. Such vehicles include vehicles with a covered rear or irregularly-shaped rear, vehicles with a rear below a certain height, and unladen carriers.

- This feature may miss stationary or slow-moving vehicles, especially at night when the driver needs to pay extra attention.

The following situations may cause late recognition and response in Adaptive Cruise Control because the target is not directly ahead, which include but are not limited to:

- Adaptive Cruise Control will not respond to targets in the sensor blind zone. For example, Adaptive Cruise Control cannot detect the blind spots at the corners of the vehicle and the blind spots on the sides of the vehicle
- When approaching or turning along a road, some targets may be misselected or missed, resulting in unexpected acceleration and deceleration of the vehicle
- When going uphill, it may miss a target or misjudge the distance between itself and the vehicle ahead. When going downhill, it may accelerate the vehicle, causing it to exceed the cruising speed
- When only part of the body of a vehicle in the adjacent lane cuts in front of your vehicle (especially when it's a larger vehicle cutting in, like a bus, truck, etc.), it may not be able to recognize the target in a responsive manner and require you to take control in time
- When your vehicle abruptly cuts into the rear of the vehicle ahead, or another vehicle abruptly cuts into or out of the front of your vehicle, it may not be able to recognize the target in a responsive manner and require you to take control in time

### Caution

- In rare cases, this feature may accelerate your vehicle even when it is not necessary or intended due to a change in, or loss of, the target (especially when cornering or changing lanes).
- In rare cases, this feature may apply the vehicle's brakes when it is not necessary or intended due to the detection of vehicles or objects, or a change in, or loss of, a stationary target in the adjacent lane (especially when cornering or changing lanes).
- When following the lead vehicle, if your vehicle or the lead vehicle switches out of the current lane, acceleration may be restricted by this feature for a certain period of time for your safety. You can take over by pressing the accelerator pedal.

**Warning**

This feature does not guarantee that the target can be accurately recognized in all situations. Please take over promptly if you find that the target lead vehicle shown on the digital instrument cluster does not match the actual situation. For example:

- A vehicle is in front of you, but the digital instrument cluster shows none.
- No vehicle is in front of you, but the digital instrument cluster shows a vehicle.

When driving in special or complex road conditions, it is not recommended to activate Adaptive Cruise Control because it may affect the performance of Adaptive Cruise Control, or even cause deactivation, which include but are not limited to:

- Waterlogged roads, muddy roads, potholes, ice- and snow-covered roads, roads with speed bumps, roads with obstacles
- Traffic conditions with a lot of pedestrians, bicycles or animals
- Complex and changeable traffic conditions, such as busy intersections, expressway ramps, congested roads
- Winding and turning roads, rapid turning roads
- Uphill and downhill roads
- Rough roads
- Narrow roads
- Tunnel entrances and exits
- Non-standard roads
- Roads without a median

In the following situations, if the vehicle is driving too fast relative to the vehicle ahead, Adaptive Cruise Control may be subject to limited control, which will result in an inability to maintain the safe distance in a responsive manner, which include but are not limited to:

- Sudden maneuvers of the vehicle ahead (such as sudden turns, acceleration, deceleration, etc.)
- Another vehicle abruptly cutting in or out of the front of your vehicle
- Your vehicle abruptly cutting in behind the vehicle ahead



- Your vehicle driving towards a stationary or slow-moving target at a high speed

It may not be able to provide sufficient braking force in the following situations, which include but are not limited to:

- The brake function cannot fully work (such as when brake parts are too cold, too hot, wet, etc.)
- Improper vehicle maintenance (excessive wear of the brake or tires, abnormal tire pressure, etc.)
- The vehicle is driving on special roads (such as uphill and downhill, water, mud, potholes, ice and snow roads, etc.)

### **Warning**

This feature is not recommended for use in bad weather conditions, including but not limited to heavy rain, snow, fog, and haze.

The above warnings, precautions and restrictions have not fully described all the situations that may affect the normal operation of the Intelligent Adaptive Cruise Control system. There are many factors that may interfere with the Intelligent Adaptive Cruise Control system. In order to prevent accidents from occurring, you need to drive attentively and focus on the traffic, road, and vehicle conditions.

## Semi-Automatic Parking Assist

Semi-Automatic Parking Assist (S-APA with Fusion) uses surround-view cameras and ultrasonic sensors to detect ground markings or parking spaces between two vehicles, so as to provide parking assistance.

Semi-Automatic Parking Assist supports perpendicular parking, parallel parking, and angled parking, but does not support parking in three-dimensional parking spaces.

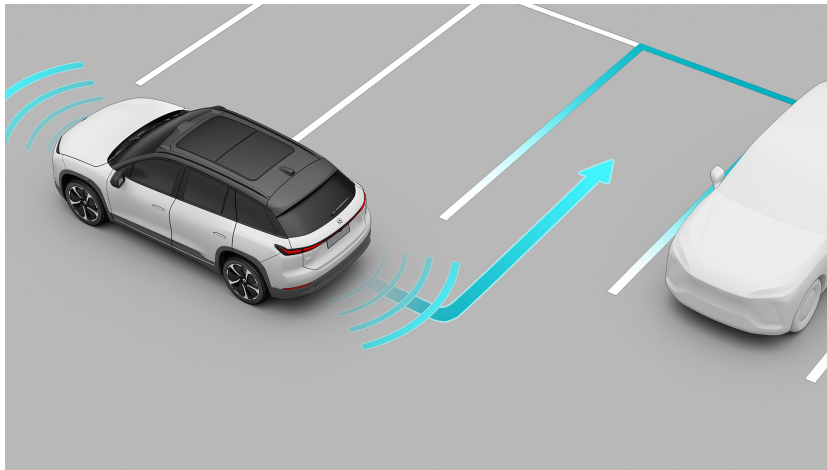

### Caution

The current version of this feature only supports parallel parking without buffer stops, and may fail to park when there is a parking stop at the bottom of the parking lot. The feature is still under optimization.

In order to ensure proper and safe operation of this feature, please always keep your seat belt fastened when using this feature.

### Warning

Do not use Shiftless Advanced Parking Assist with Fusion on roads which are sloped or uneven.

Do not use Shiftless Advanced Parking Assist with Fusion while the vehicle is being charged.

### Warning

The performance of Shiftless Advanced Parking Assist with Fusion depends on the capabilities of the surround view camera and ultrasonic sensors to detect and identify the environment.

Do not use Shiftless Advanced Parking Assist with Fusion if any one of the two side mirrors, the surround view camera, and the ultrasonic sensors is damaged or in an abnormal position.

### **Warning**

You should pay special attention to pedestrians, children, and animals near your vehicle, and other fine, pointed, low or suspended obstacles undetected by the ultrasonic sensors, such as parking locks, low stone blocks, traffic cones, low cylinders, thin rods, pointed objects, corners of walls, and square columns in parking lots.

### **Warning**

As a driving assist feature, Shiftless Advanced Parking Assist with Fusion cannot handle all situations in all traffic, weather, road, and light conditions.

You must always pay attention to traffic and road conditions, and decide to use Shiftless Advanced Parking Assist with Fusion or not after your safety is ensured.

You should always be ready to take over if you find that the conditions of the traffic, road or vehicle are not suitable for enabling Shiftless Advanced Parking Assist with Fusion, or there are other safety risks. You always bear the ultimate responsibility for parking safely and complying with applicable traffic laws and regulations.

### ***Activating Semi-Automatic Parking Assist***

Semi-Automatic Parking Assist parks the vehicle as follows:

1. Parking space search: Enter the Dual-view Image page and open Parking Space Search. Drive forward slowly at a speed of less than 16 km/h, and stop after the digital instrument panel shows that a parking space has been found. Keep the brake on, check and choose a safe and suitable parking space;
  - Manual parking space search: Enter the Dual-view Image page and open Parking Space Search. Drive forward slowly at a speed of less than 16 km/h, and stop after the digital instrument panel shows that a parking space has been found. Keep the brake on, check and choose a safe and suitable parking space;
  - Auto parking space search: When the road conditions and system conditions are met, drive forward slowly at a speed of less than 16 km/h. When a parking space is found in the background, the Parking assist

button  will appear on the Map page. Touch the button and stop the vehicle according to the text prompts on the page. Keep the brake on, check and choose a safe and suitable parking space;

2. Parking: Select a safe and suitable parking space, and park the vehicle according to the text prompts on the page. Keep checking the surroundings to ensure that the vehicle is parked safely;
3. Parking completed. The Dual-view Image page will prompt Parking Completed.

Details are as follows:



#### 1. Parking Space Search

Before searching for a parking space, the vehicle must meet the following conditions:

- Your vehicle speed is lower than 16 km/h
- Your vehicle is in the D or R gear position
- All doors are closed
- Driver seating status
- ACC/LCC not enabled
- Ultrasonic sensors and surround-view cameras functioning properly with a clear view
- No system error
- Anti-lock brake system, traction control system and vehicle stability control system are not triggered
- Traction control system, vehicle stability control system are not disabled
- Not available in ECO+ Mode

When the above conditions are met, you can initiate Parking Space Search in any of the following ways:

- Where the parking camera is off, say a command like “I want to park” or “Park the vehicle” to wake up NOMI, which will open the Dual-view Image page directly and enter Parking Space Search
- Swipe right on the main page of the central display to enter the Quick Settings page, tap **Parking Assist**, enter the Dual-view Image page and open Parking Space Search

- Put your vehicle in Reverse, enter the image page, and tap the  button in the upper left corner to open Parking Space Search
- Tap the parking camera to enter the 360-degree image page, tap the  button in the upper left corner to open Parking Space Search

After turning on Parking Space Search, keep the vehicle at a distance of 0.5m to 1.5m to the target parking space, and drive forward slowly at a speed of less than 16 km/h to search for a parking space.

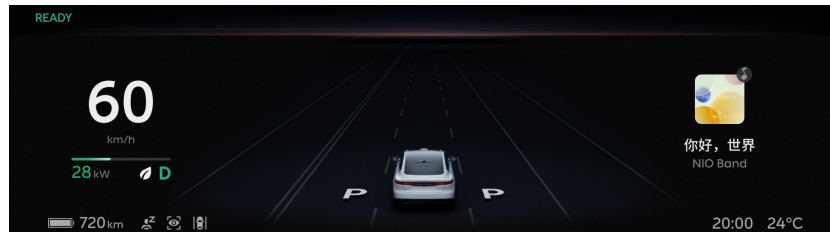

During the search for a parking space, when a white “P” appears on the left or right side of your vehicle on the screen, it means that the system has found a parking space on the corresponding side. If a “P” appears on both sides, it means that the system has found parking spaces on both sides.

Stop the vehicle at this time, keep the brake on, and check whether the parking space is safe and suitable. If multiple parking spaces are found, you can manually select the appropriate parking space on the Dual-view Image page.

### Note

After the vehicle starts searching a parking space, if you shift into REVERSE and reverse the vehicle, it will continue searching.

### Caution

When the vehicle's speed is above 16 km/h, the parking space search will be canceled.

### Caution

When searching for parking spaces, parking may not be successful if the vehicle's direction has significantly deviated from the direction of the road.

### Caution

Parking spaces on narrow roads or spaces that are too narrow may not be selected due to a lack of space.

Shiftless Advanced Parking Assist with Fusion does not support parking space search and lateral shift in a parking space.

### Caution

Semi-Automatic Parking Assist can be used to identify the barrier-free parking space sign in the parking space. After successful identification, the barrier-free parking space will display the corresponding icon in the parking space page at the lower left. The identification of the barrier-free sign in the non-parking space, such as erected metal plates and text signs, is not supported now. In addition, this type of parking space may be misidentified. Please select a parking space as required according to the actual situation.

### Warning

- You must always check and confirm if the detected parking space is safe and suitable for parking. Do not rely solely on Shiftless Advanced Parking Assist with Fusion to search for suitable parking spaces.
- This feature is not available on high-speed roads and urban expressways.
- Never use this feature in the Trailer Mode.
- The system may misidentify parking spaces on roads, at entrances, in bushes, etc. You need to determine if the parking space is suitable.
- Shiftless Advanced Parking Assist with Fusion cannot determine if the detected parking space is legitimate. You need to confirm the legitimacy before starting the parking procedure.

## 2. Parking

Select a safe and suitable parking space, release the steering wheel and brake pedal according to the text prompts on the page, then initiate Semi-Automatic Parking Assist. During the parking process, the page will display the current gear and the remaining length of the route in this gear as a reference. Keep checking the surroundings to ensure the safety of the parking process. After selecting a parking space, you can de-select it by tapping the space again before releasing the brake pedal.

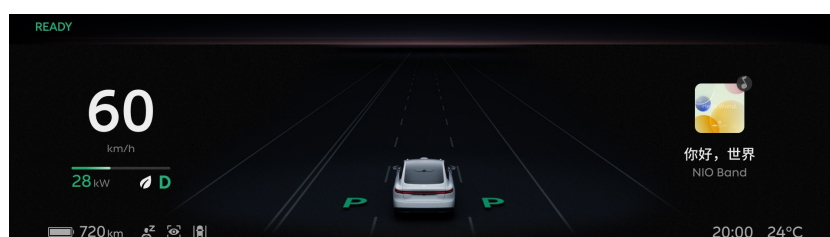

When the vehicle is parked, the “P” on the left or right side of the vehicle in the digital instrument panel will turn green.

### **Caution**

Please only release the brake pedal when you receive the prompt “Release the brake pedal and the steering wheel” on the center display. Otherwise, Shiftless Automatic Parking Assist will cancel and the vehicle will move backwards.

### **Warning**

Before releasing the brake pedal, make sure that your hands and arms do not interfere with the steering wheel to avoid any injuries caused by its rapid movement. When parking, always be prepared to apply the brakes to pause the process or take over.

### **Warning**

Initiating Shiftless Advanced Parking Assist with Fusion in a narrow parking space may affect the performance of the sensors, which can increase the risk of damaging the vehicle or surrounding objects.

### **Warning**

You are responsible for driving safely. Always pay attention to your surroundings when parking, ensure that the parking process is safe, and be prepared to take over at any time. In particular, you should pay special attention to pedestrians, children, or animals near your vehicle, and other fine, pointed, low, or suspended obstacles the ultrasonic sensors may not be able to detect.

Any retrofits or modifications made to the steering wheel, including but not limited to steering wheel cover, steering wheel modification, and counterweight ring, will increase the parking risk caused by failed or affected Shiftless Advanced Parking Assist with Fusion.

The center display only shows available parking spaces that Shiftless Automatic Parking Assist is capable of parking in, which are subject to both the size of the parking space and its surroundings. If you spot any obstacles that suddenly appear around the car while parking, take over immediately as the system may not apply the brakes in time.

## 3. Parking Completed

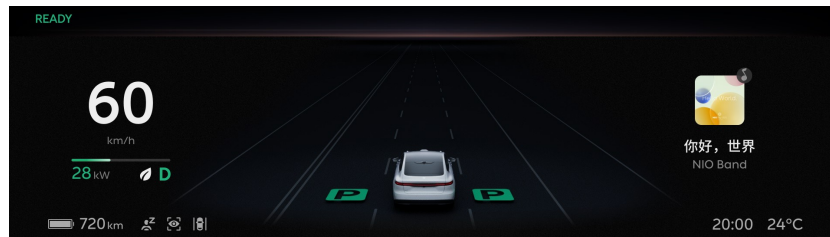

The vehicle is properly parked when the Dual-view Image page prompts “Parking Completed”, and the “P” on the left or right side of the vehicle in the digital instrument panel turns green.

After parking, you may need to make further adjustments to the vehicle in order to ensure that the vehicle is in the best parking position.

Before leaving, make sure that the electronic parking brake is activated and the vehicle is in Park.

### Caution

Parking may be finished in advance due to the surroundings. In this case, you may need to adjust the vehicle’s position manually.

### ***Pausing parking***

During the process of parking under Semi-Automatic Parking Assist, you can lightly step on the brake pedal to slow the vehicle down without disengaging the feature; only when you keep stepping on the brake pedal until the speed is reduced to 0 km/h, will the feature be suspended. In addition, stepping on the accelerator pedal during parking will also suspend the parking.

If you actively intervene with the steering wheel, the parking feature will be suspended.

Intervention includes, but is not limited to, the process of perpendicularly backing into a parking space with Semi-Automatic Parking Assist active, if the system detects that there may be a safety risk or the parking result cannot be guaranteed, the system will pause parking and ask you whether to continue parking.

After parking is paused, check the surroundings to ensure that it is safe to continue parking, then release the brake pedal, and tap the “Resume Parking” button on the central display to re-activate Semi-Automatic Parking Assist.

### Caution

Parking may be impaired if you pause too many times during the parking process.



### ***Deactivating Semi-Automatic Parking Assist***

You can deactivate Semi-Automatic Parking Assist manually in the following ways. Take over control of the speed and direction of your vehicle after actively disengaging Semi-Automatic Parking Assist:

- Step on the brake pedal and shift gears
- When Semi-Automatic Parking Assist is suspended, tap the “Stop Parking” button on the Dual-view Image page
- Actively exit the Dual-view Image page

In addition, when Semi-Automatic Parking Assist is active, the following situations will cause the ongoing parking to stop, requiring you to take control of the vehicle in time:

- Too close to an obstacle
- Front trunk, tailgate or any door is open
- Electronic parking brake is activated
- Anti-lock brake system, traction control system and vehicle stability control system triggered
- Driver leaves seat
- Semi-Automatic Parking Assist has been suspended for more than about 30 seconds
- Too many front and rear adjustments
- The overall parking process has timed out
- System fault

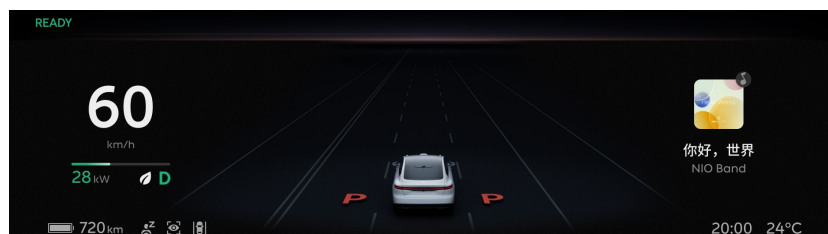

When Semi-Automatic Parking Assist is deactivated abnormally, the “P” on the left or right side of the vehicle in the digital instrument panel will turn red.

***Precautions and Restrictions***

Semi-Automatic Parking Assist may not be able to function as expected when the vehicle is driving under the following road conditions, which include but are not limited to:

- Do not activate Semi-Automatic Parking Assist when the road surface is slanted or sloped. Semi-Automatic Parking Assist is only designed for use on road surfaces with no gradients.
- Do not activate Semi-Automatic Parking Assist if the road surface is uneven or there are steps on the road. Semi-Automatic Parking Assist is designed for use on flat roads only.
- Do not activate Semi-Automatic Parking Assist if there is water, mud, potholes, ice and snow, speed bumps, and obstacles on the road.
- Do not activate Semi-Automatic Parking Assist if the curb material is special or cannot be detected. If parked improperly, the tires and rims of the vehicle are at risk of being damaged by the curb, and you need to promptly take control of the vehicle.
- When the road surface is slanted or the slope is beyond the supported range, the success rate of Semi-Automatic Parking Assist cannot be guaranteed.
- If the angle of the slanted parking space exceeds the supported range, the parking space will not be released, and the success rate for parking cannot be guaranteed.

Ultrasonic sensors may have limited detection of the following obstacles, requiring you to be ready to take control of the vehicle at any time, so as to prevent property damage or personal injury, which includes but is not limited to:

- Pedestrians, children, animals, etc.
- Thin, pointed, short, and suspended obstacles, such as ground locks, low stone piers, low cylinders, thin rods, sharp objects, etc.
- Wall corners, parking lot columns, etc.

Ultrasonic sensors may have limited detection in the following situations, resulting in Semi-Automatic Parking Assist being unable to function or not functioning as expected, which includes but is not limited to:

- One or more ultrasonic sensors are damaged, misplaced, or obscured (such as by mud or ice)

- Severe weathers like rain, snow, fog, and haze affect the performance of ultrasonic sensors
- Sensors are affected by other electrical equipment or installations that can cause interference

The surround-view camera may have limited detection in the following situations, resulting in Semi-Automatic Parking Assist being unable to function or not functioning as expected, which includes but is not limited to:

- The left and right exterior rearview mirrors or the front and rear of the vehicle are damaged, resulting in an abnormal position of the surround-view camera
- The surround-view camera is soiled (such as by mud or ice) or obscured
- Under strong sunlight or dappled tree shade
- Reflective ground or water on the ground
- Poor lighting conditions (dark), strong reflection from the ground, or poor visibility (heavy rain, heavy snow, dense fog)
- A parking space of an unconventional size (too narrow or too wide), or a tile-paved parking space
- Worn, unclear, covered, or overlapping parking space lines
- Cylindrical, square and other shaped pillars near the parking space
- Parking space at a corner
- The system may not be able to judge and exclude parking spaces with no-parking markings, cones, restricted-stop signs, ground locks, or other special parking spaces
- The system may not be able to exclude parking spaces with obstacles, such as pedestrians, bicycles, tricycles, low debris, bricks, etc.

Semi-Automatic Parking Assist may not be able to function as expected when the vehicle is driving in the following situations, which include but are not limited to:

- Any addition or modification of the steering wheel, which will increase the risk of parking and may cause the Semi-Automatic Parking Assist to not work, or not function as expected, which includes but is not limited to: installing a leather steering wheel cover, or modifying the steering wheel or weight ring, etc.
- Do not activate Semi-Automatic Parking Assist if a trailer is attached to the rear of the vehicle.

- Do not activate Semi-Automatic Parking Assist if the vehicle is fitted with snow chains or a spare wheel.
- Do not activate Semi-Automatic Parking Assist if a loaded object protrudes into the area surrounding the vehicle.
- Non-original tires or low tire pressure will affect the driving trajectory of Semi-Automatic Parking Assist. When Semi-Automatic Parking Assist is active, make sure the tires are original and properly inflated.
- After changing the tire size and specifications, you need to update the relevant parameters at the After-sales Services. Currently only the tire models specified by us are supported; any modification of the vehicle's tire size and specifications may affect parking performance.

Semi-Automatic Parking Assist may not be able to function as expected due to the following target parking space conditions, which include but are not limited to:

- The target parking space is adjacent to the roadside fence, high walls, street lights, trees, bushes, pillars, suspended obstacles such as railings, distribution boxes, EV chargers, etc., which will affect the final parking effect and may even cause vehicle damage.
- The target parking space is on a curve, which will affect the final parking effect.
- Do not activate Semi-Automatic Parking Assist when the target parking space is at an angle.
- Do not activate Semi-Automatic Parking Assist when there are obstacles such as unlocked ground locks, cones, shopping carts, and lampposts in the target parking space.

Do not activate Semi-Automatic Parking Assist when the following conditions may lead to poor vision of the observed environment while driving, which include but are not limited to:

- Any one of the left and right exterior rearview mirrors is blurred, damaged or in an abnormal position.
- The surround-view camera is blurry, damaged, or in an unusual position.
- Inclement weather (rain, snow, fog, haze, etc.) results in poor visibility.
- Poor vision at night or due to insufficient light.

Do not activate Semi-Automatic Parking Assist repeatedly in the following situations, which include but are not limited to:

- After vigorous driving or repeated parking operations, which may trigger overheating protection of the steering system. Do not activate Semi-Automatic Parking Assist for prolonged periods of time or repeatedly.

The above warnings, precautions and restrictions have not fully described all the situations that may affect the normal operation of the Semi-Automatic Parking Assist with Fusion system. There are many factors that may interfere with the Semi-Automatic Parking Assist system. In order to prevent accidents from occurring, you need to drive attentively and focus on the traffic, road, and vehicle conditions.

## Power Station Automatic Parking (PSAP)

The Power Swap Station Automatic Parking (PSAP) can help drivers park their vehicles in the second generation Power Swap Station without any steering wheel input, braking, acceleration, or gear shift operations.

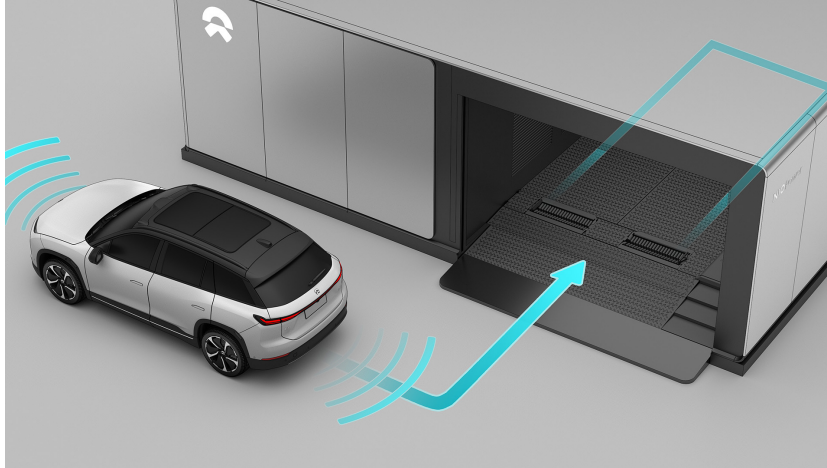

Search for the Power Swap Station on the map, or open the power-up assistant to screen the Power Swap Station:

- If you are within the order placing range of the Power Swap Station, directly tap to place an order;
- If you are not in the order placing range, navigate to the Power Swap Station and place an order when you arrive nearby.

### Caution

- The locations of your vehicle and the NIO app are checked during order placement. An order cannot be placed successfully unless your vehicle is within 200m of the power swap station.
- In the event of an order placement failure due to unavailable vehicle network, please try again after the network resumes or consult the field specialist.
- Please read the Agreement and Disclaimer before placing an order.

When the order is placed successfully, a power swapping serial number will be generated to enter the queuing sequence. You can check the battery's charging status, the number of people in the current queue, the estimated waiting time and other information on the order page of the mobile APP and the vehicle.

After the previous vehicle finishes the power swap and leaves the Power Swap Station, the Power Swap Station will send a number calling command after

checking to notify you to enter the station for the power swap. Tap the "Activate Power Swap Process" button on the central display to start the parking process.

### Caution

- Please wait for your turn near the power swap station and pay attention to the queuing status on your center display or NIO app. If you miss your turn, please contact the field specialist in time.
- If you have to leave the power swap station for some reason, please pay attention to the queuing status on the NIO app or cancel the order in time.
- Please avoid the lane in front of the station when waiting for power swap.

The Power Swap Station Automatic Parking (PSAP) function may not operate as expected in the following situations:

- The material that the curb is made out of is not stone or the curb is undetectable. If parked improperly, the tires and rims of the vehicle are at risk of being damaged by the curb, and you need to promptly take control of the vehicle.
- Any addition or modification of the steering wheel, which will increase the risk of parking and may cause the Semi-Automatic Parking Assist to not work, or not function as expected, which includes but is not limited to: installing a leather steering wheel cover, or modifying the steering wheel or weight ring, etc.
- One or more ultrasonic sensors are contaminated or obstructed (e.g. sludge or ice and snow).
- Weather conditions (heavy rain, snow, fog, extreme heat or cold, etc.) interfere with the operation of the sensor.
- Reflective ground or water on the ground
- Sensors are affected by other electrical equipment or installations that can cause interference
- The road surfaces are uneven, have grass planting bricks, grooves, etc..
- It is equipped with snow chains or spare wheels.
- The loaded objects protrude around the vehicle.
- Any one of the left and right exterior rearview mirrors is damaged or in an abnormal position.

**Caution**

- After the tire size is changed, you need to go to the service center to update the relevant parameters. Currently, only the official tire models are supported. Any modification related to the vehicle tire size and performance may affect the parking performance.
- Parking may be impaired if you pause too many times during the parking process.
- High-speed driving or multiple parking operations may trigger overheat protection for the steering system. Do not use this feature repeatedly for an extended period.
- When the target parking space is close to roadside fences, high walls, street lights, trees, bushes, pillars, or overhanging obstacles such as railings, power distribution boxes and charging connectors, these obstacles may affect the parking result and even cause vehicle damage.

***Park into the Power Swap Station.***

After tapping the "Activate Power Swap Process" button, please enter the starting area for the power swap in the specified direction at a speed lower than 18 km/h according to the vehicle's instructions.

**Caution**

- A high speed may cause positioning detection failure. Please keep the speed below 18 km/h.
- Please drive as instructed by the arrows on the ground and avoid vehicles and pedestrians around.
- If positioning detection fails, please contact the field specialist to take over your vehicle and manually reverse for power swap.

After entering the starting area for the power swap, when the dynamic environment simulation displays and NOMI plays a voice prompt saying that the vehicle has been successfully located, please press the brake pedal to keep the vehicle stationary and wait for positioning detection.

Make sure your seat belt is fastened and the door is closed while you wait in the starting area.



Tap the "Assist in Parking Into the Power Swap Station" button. When you see "Please release the brake and steering wheel", follow the instructions to start parking in the Power Swap Station.

- Parking will be suspended if obstacles are detected during the process.
- If parking is suspended due to systemic reasons or active intervention during the process, please confirm that there are no obstacles in the surrounding area and manually resume the parking.

If you are unable to continue parking, you can select "Terminate Parking", and the on-site specialist will manually swap power for the vehicle after you quit. If the Power Swap Station is unattended, users can choose to park automatically or manually again, or contact the specialist.

After parking is completed, swap power for the vehicle as instructed on the page.

### Caution

Before or during parking into the power swap station, please always pay attention to your surroundings to confirm that there are no passing vehicles, pedestrians, children, etc. and ensure parking safety.

Please do not take over the accelerator pedal, unbuckle the seat belt, leave the driver's seat, or open the door during parking into the power swap station.

### ***Start/end the power swap.***

After parking successfully in place, it will automatically enter the one-button Power Swap process. Please read the instructions on the vehicle's screen carefully and tap to start the power swap.

The vehicle will automatically adjust to the power swap status, and switch off the screen to start the power swap.

### Warning

If your vehicle is not parked in place or failed to be automatically adjusted, please adjust your vehicle as instructed by the field specialist.

The windows or air conditioning cannot be adjusted during the power swap. Please adjust them to proper positions in advance.

During the power swap, it is normal that the vehicle jerks slightly with some noise and some warning lights are on temporarily.

During the process, do not try to open any door, shift gears, press the brake pedal, or perform other actions, which may cancel the power swap abnormally.

After the power swap is completed, the vehicle's screen will light up to indicate that the power swap has been completed. At this time, it can drive away from the Power Swap Station without any problems.

### **Caution**

Please pay attention to any vehicles or pedestrians in front for safety before exiting the power swap station.

The above warnings and precautions have not fully described all the conditions that may affect the normal operation of the Power Swap Station Automatic Parking (PSAP) system. There are many factors that may interfere with the Power Station Automatic Parking (PSAP) system. In order to prevent accidents from occurring, you need to drive attentively and focus on the traffic, road, and vehicle conditions.

## Side Distance Indication System (SDIS)

The Side Distance Indication System (SDIS) function monitors the front of the vehicle when it is driving at a low speed with ultrasonic sensors. When approaching obstacles, the parking camera page and scenes like assisting in judging the parking space or passing restricted roads will be automatically called up.

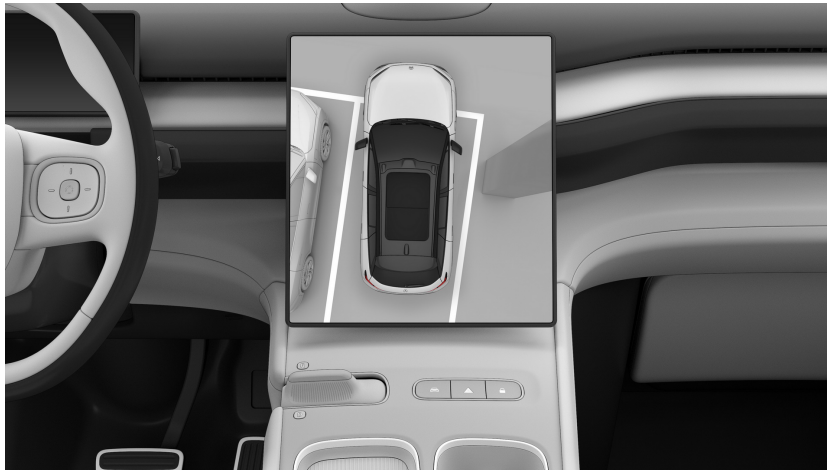

### Warning

Side Distance Indication System serves as a reference only, and cannot substitute your visual observation.

As a driving assist feature, Side Distance Indication System cannot handle all situations in all traffic, weather and road conditions. We do not recommend using Side Distance Indication System in bad weather conditions, including but not limited to heavy rain, snow, fog, and haze.

You must always pay attention to traffic and road conditions, and make your own decision on whether to use Side Distance Indication System if it is safe.

It is always your responsibility to ensure that the vehicle is driven in a safe manner and complies with applicable traffic laws and regulations.

### ***Enable/Disable Side Distance Indication System (SDIS) function***

The Side Distance Indication System (SDIS) function can be enabled or disabled by the settings button on the parking camera page. When the Side Distance Indication System (SDIS) is enabled, different layout styles can be selected, such as dual-view, full-screen, and picture-in-picture.

When the following working conditions are simultaneously satisfied, the parking camera page will be automatically activated:

- Vehicle in D gear
- The speed does not exceed 21 km/h
- There are obstacles in any of the areas ahead and the distance is close to the vehicle.

### Area and range of the Side Distance Indication

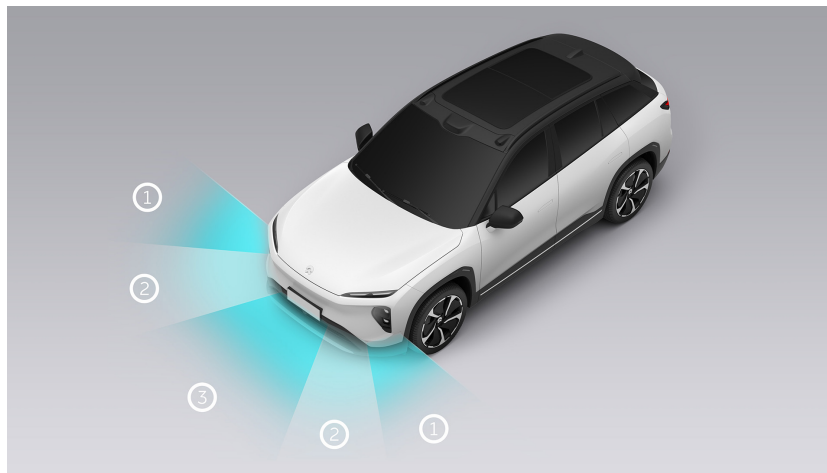

Area	Range
1	Distance within 50cm
2	Distance within 80cm
3	Distance within 80cm

You can click on the upper right side of the parking camera page and select to turn off the warning tone. At the same time, you should bear all the risks caused by turning off the warning tone.

### Automatic exit of the parking camera page:

- When the obstacle is more than 4.5 seconds away from the vehicle, the parking camera page will automatically exit.
- When the Side Distance Indication System (SDIS) is turned off by tapping the blank area of the parking camera or grabbing the screen with five fingers, it can be temporarily disabled for 3 minutes, and normal use can be resumed 3 minutes later.

- When the vehicle's speed exceeds 21 km/h, the Side Distance Indication System (SDIS) will return to normal use.
- When the working conditions for the Side Distance Indication System (SDIS) function are satisfied again, the parking camera page will be automatically activated.

### **Warning**

This feature is not recommended for use in bad weather conditions, including but not limited to heavy rain, snow, fog, and haze.

The above warnings do not cover all conditions that may affect the proper operation of the Side Distance Indication System (SDIS). There are many factors that may interfere with the Side Distance Indication System (SDIS). In order to prevent accidents from occurring, you need to drive attentively and focus on the traffic, road, and vehicle conditions.

## Vehicle Health Status

Please check the vehicle status regularly to keep it in the best condition. You can tap **My EL7 > Health** on the center display to check vehicle health status. On this interface, the vehicle performs a self-inspection and displays the current health status.

At the same time, you can check the consumption of the current trip in **My EL7 > Consumption** and reset the trip in **Reset Cumulative Trip**.

## Maintenance Instructions

To ensure that the vehicle can operate normally and bring a good driving and riding experience, you need to conduct regular vehicle maintenance.

In light of the complexity of vehicle systems and the after-sales service requirements of electric vehicles by national laws and regulations, we recommend you to have your vehicle maintained regularly at NIO's service center. If you have any inquiries about the vehicle inspection, please contact NIO at any time.

## Regular Maintenance

Regularly maintaining your vehicle is very important to keep its performance, usage cost and service life in a good condition. We recommend you to have your vehicle regularly maintained at NIO's service center.

### ***Daily Inspection***

Conducting daily vehicle inspections is very important to ensure driving safety and reduce vehicle failures. Please check the following items on a daily basis. If you identify any problems, contact NIO immediately to conduct relevant inspections.

- Check whether all exterior lights, speakers, turn signals, and hazard warning lights are working properly.
- Check whether the windshield wipers and washer system are working properly.
- Check whether the braking system is working properly.
- Check whether the seat belts are working properly.
- Check if there are any warning indicators or information on the instrument cluster and the center display.
- Check the tire pressure and tread wear of each tire.
- Check whether there are any abnormal fluids under the vehicle (water condensation from the air conditioning system is normal).
- When driving, check if there are any unusual noises such as bump or crash sound from the underbody.
- Check the vehicle body for contaminants that may damage the paint (such as bird droppings, resin, road tar, insects, or industrial dust), If any, please clean them as instructed in "Exterior Cleaning".
- Check the areas around the roof LiDAR sensor, HD cameras and surround view cameras for contaminants. If any, please clean them as instructed in "Exterior Cleaning".
- Replace the battery of the smart key fob as instructed on the center display.

### ***Regular Maintenance***

In normal driving conditions, please contact NIO to have your vehicle maintained according to the following service items and intervals:

- Gearbox oil: Replace it every 200,000 kilometers.
- Brake fluid: Replace it every 36 months.



- **Coolant:** Check the coolant at the 5th year or 100,000 kilometers (whichever comes first) at the latest, and replace it if necessary.  
If the coolant has not been replaced, check it every 24 months or 40,000 kilometers (whichever comes first), and replace it if necessary. If the coolant has been replaced, check the new coolant at the 5th year or 100,000 kilometers (whichever comes first), and replace it if necessary.  
If the vehicle is used in extremely cold weather (below  $-30^{\circ}\text{C}$ ), check the coolant and replace it if necessary.
- **Brake pads:** Check the brake pads for wear at the 5th year or 100,000 kilometers (whichever comes first) at the latest, and replace them if necessary.  
If the brake pads have not been replaced, check them every 24 months or 40,000 kilometers (whichever comes first), and replace them if necessary. If the brake pads have been replaced, check them for wear at the 5th year or 100,000 kilometers (whichever comes first), and replace them if necessary.
- **Brake discs:** Check the brake discs for wear at the 10th year or 200,000 kilometers (whichever comes first) at the latest, and replace them if necessary.  
If the brake discs have not been replaced, check them every 24 months or 40,000 kilometers (whichever comes first), and replace them if necessary. If the brake discs have been replaced, check the brake discs for wear at the 10th year or 200,000 kilometers (whichever comes first), and replace them if necessary.

### ***Unscheduled Maintenance***

It is recommended to contact NIO to have your vehicle maintained as needed, depending on the condition of your vehicle and the instructions on the central display:

- Check the wiper blades for aging and wiping effects, and replace them if necessary.
- Check the air filter as instructed on the central display and replace it when necessary.
- Replace the 12V battery as instructed on the center display.

It is recommended to contact NIO for a full vehicle health check as needed, depending on the operating environment and condition of your vehicle.

***Special Maintenance***

If you often drive your vehicle in the following harsh environments, additional maintenance or shorter service intervals may be required. For details, please contact NIO.

- Driving in dusty environments.
- Driving in extremely cold environments (below  $-20^{\circ}\text{C}$ ) or extremely hot environments (above  $40^{\circ}\text{C}$ ).
- Driving in humid environments or wading through water frequently.
- Driving in salty or corrosive environments.
- Braking frequently or driving in mountainous areas.
- Frequently driving for special heavy-duty purposes.
- Any retrofits or modifications for special purposes.

## Front Wiper Blade Replacement

The front wipers can remove rain and stains from the windshield (when used with windshield washer fluid). After cleaned by the wipers, if the windshield becomes blurred or shows visible water marks, which in turn affects the driver's vision and does not disappear, please replace the wiper blades promptly.

The procedure to replace the front wiper blades is as follows:

1. Enter Settings from the bottom of the center display, and tap **Driving > Service Position** to move the front wipers to the service position.
2. When the front wipers move to the replacement position, they can be lifted up. Press and hold the lock button on the front wiper blade and slide the blade down perpendicular to the wiper arm to remove the wiper blade.

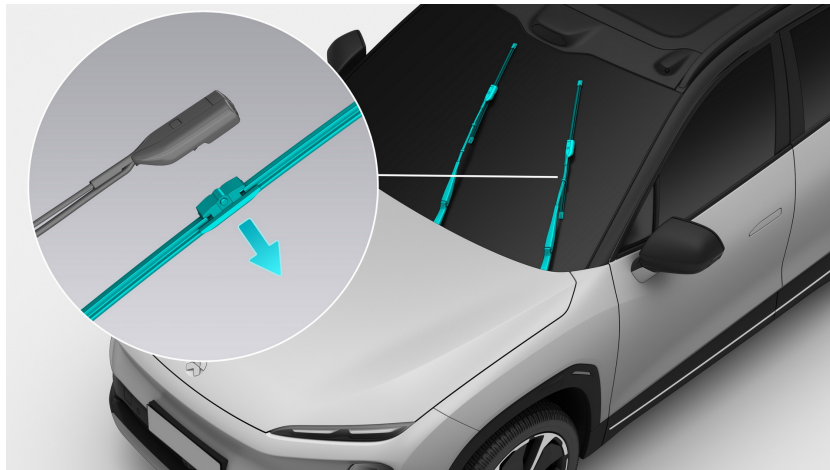

3. Insert the new wiper blade until you hear a click sound to confirm that the front wiper blade is securely installed.

## Rear Wiper Blade Replacement

The rear wiper cleans raindrops on the rear windshield. The procedure to replace the rear wiper blade is as follows:

1. Lift the rear wiper arm and remove the rear wiper blade.

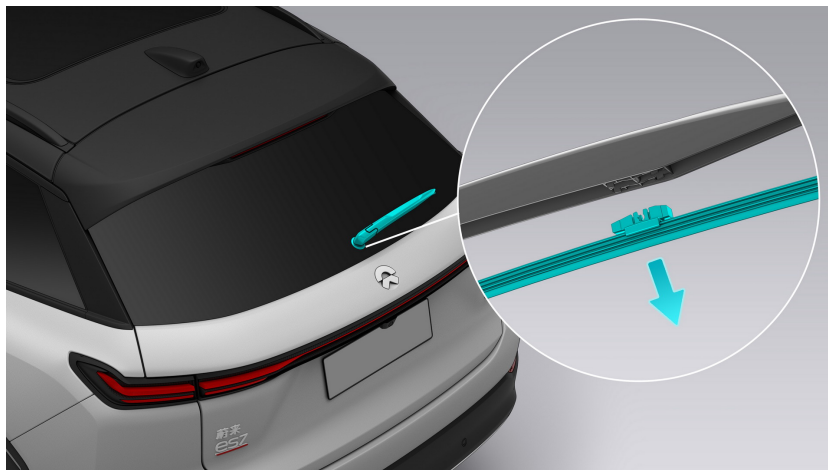

2. Install a new wiper blade and pull the wiper blade to confirm that it is securely installed.

## Windshield Washer Fluid Refill

Windshield washer fluid is used to maintain good visibility through the windshield. The procedure to refill the windshield washer fluid is as follows:

1. Open the windshield washer fluid container cap and refill an appropriate amount of washer fluid.

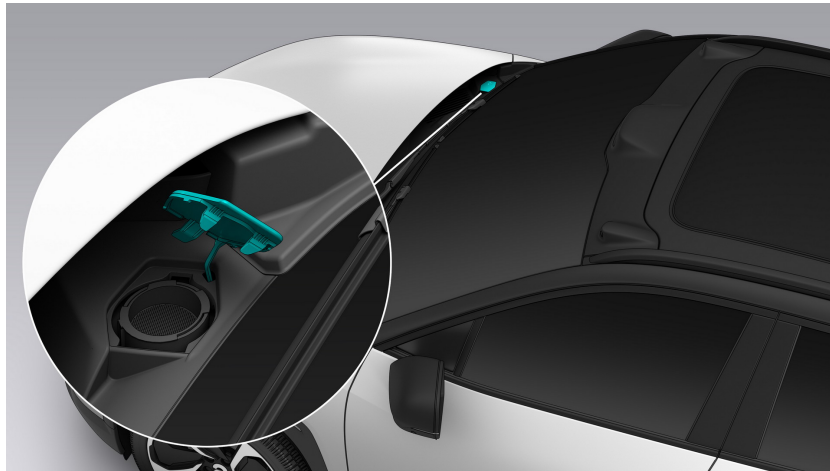

### Caution

When topping up the windshield washer fluid, please fill the reservoir carefully to avoid spilling and wipe up any spills immediately.

2. After refilling the fluid, tighten the cap.

## Coolant Refill

### Warning

To avoid the risk of high voltage electric shock when opening the hood, please contact NIO to top up the vehicle's coolant.

The coolant maintains the operation of the vehicle power system within a proper temperature range. The procedure to refill coolant is as follows:

1. Pull the hood handle cover in the cabin to unlatch the hood.



2. Toggle the hood latch.

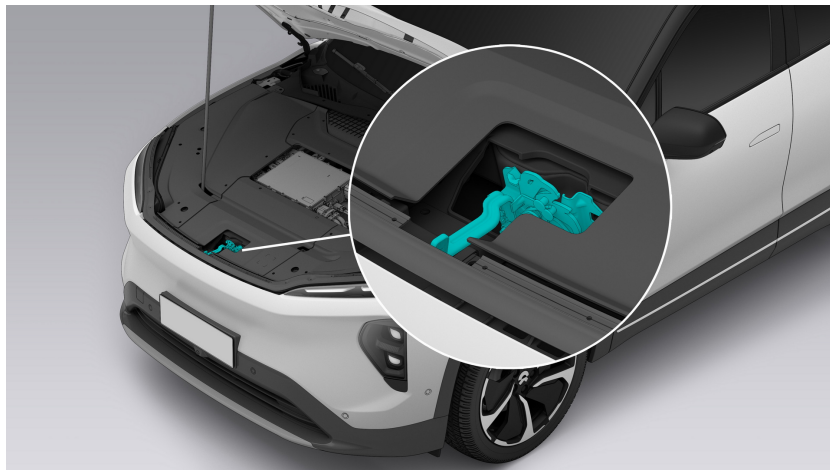

3. Lift the hood, and support it with the prop rod.

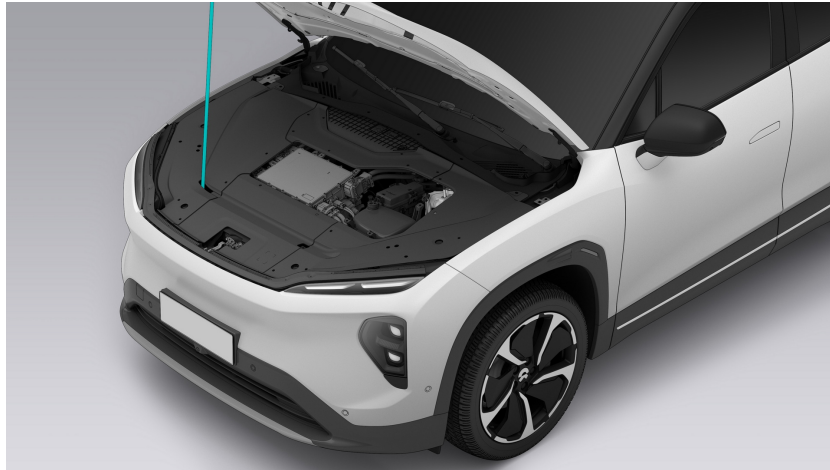

4. Open the coolant cap and add an appropriate amount of coolant (above the MIN and below the MAX indicators).

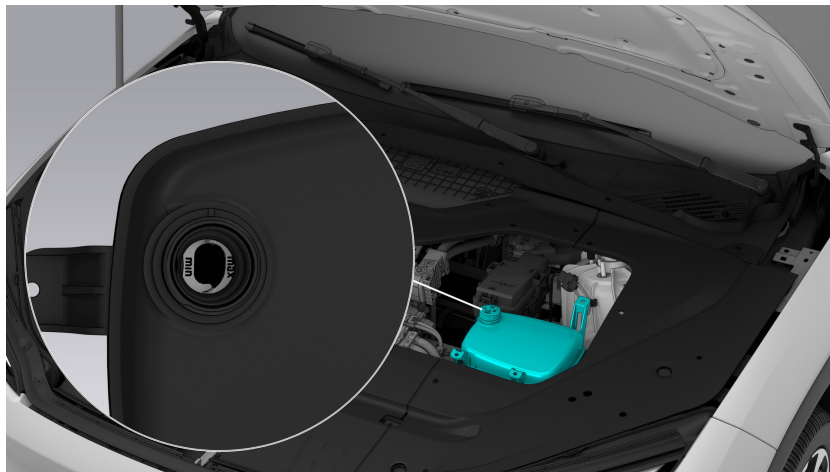

5. Close the coolant cap tightly. When closing the hood, hold the hood with your hands and lower it to an appropriate angle. Then, push the hood down firmly until it is completely closed.

**Caution**

Do not slam or drop the hood.

## Brake Fluid Refill

### Warning

To avoid the risk of high voltage electric shock when opening the hood, please contact NIO to top up the vehicle's brake fluid.

Brake fluid is the medium for transmitting brake pressure in the hydraulic brake system. The procedure to refill brake fluid is as follows:

1. Pull the hood handle cover in the cabin to unlatch the hood.



2. Toggle the hood latch.

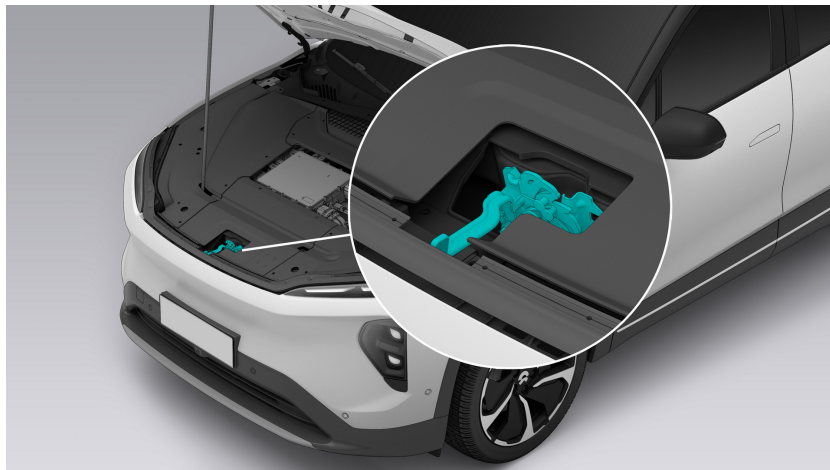

3. Lift the hood, and support it with the prop rod.



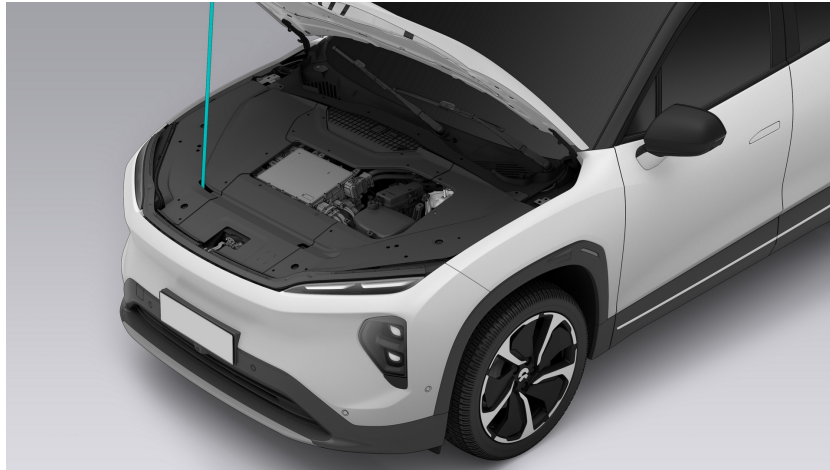

4. Open the brake fluid cap and add an appropriate amount of brake fluid (above the MIN and below the MAX indicators).

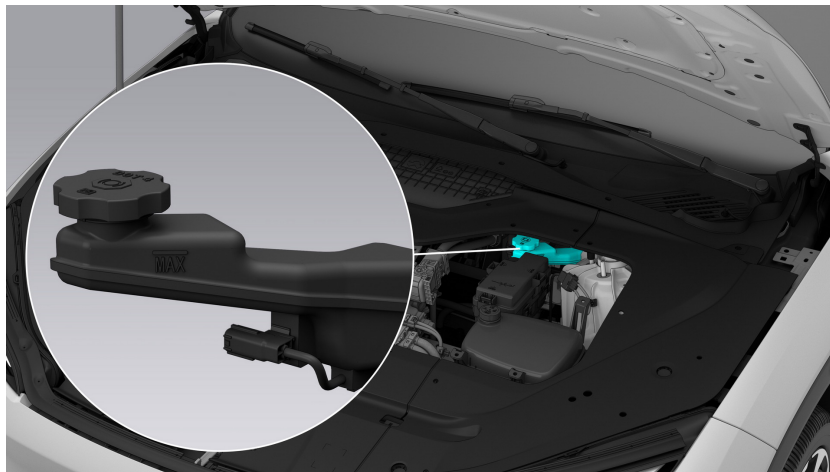

5. Close the brake fluid cap tightly. When closing the hood, hold the hood with your hands and lower it to an appropriate angle. Then, push the hood down firmly until it is completely closed.

**Caution**

Do not slam or drop the hood.

## Tire Inspection and Maintenance

Do not drive the vehicle if the tires are damaged, excessively worn, or not inflated to the correct pressure. For your driving safety, please inspect the tires regularly:

- Frequently inspect the tires for any signs of punctures, cuts, tears, wear, and bulges, and remove any foreign objects in the treads.
- A puncture causes the tire to lose pressure, which is why it is important to check tire pressures frequently. Repair or replace punctured or damaged tires as soon as possible. If you feel a sudden vibration or ride disturbance while driving, or you suspect a tire is damaged, immediately reduce your speed. Drive slowly, while avoiding heavy braking or sharp steering. Stop the vehicle when it is safe to do so and then contact NIO immediately.
- If the tire valve cap is missing, replace the missing cap as soon as possible.
- Keep the tires away from engine oil, grease, or fuel oil.
- Always store the wheels in a cool, dry, and dark place. Tires without wheels should be stored upright.
- Do not store summer tires or park vehicles fitted with summer tires at ambient temperatures below  $-15^{\circ}\text{C}$ .

Tires have wear indicators molded into the tread pattern. Check the tread pattern regularly, especially before and after long trips. When the tread has been worn down to 1.6 mm or less, the indicators will appear at the surface of the tread pattern, which indicates that tire traction is significantly reduced. In this case, replace the tire immediately. Failure to do so may increase the risk of accidents.



For safety reasons, tires must be replaced if they are damaged in any of the following ways:

- Damage to the tire, such as cuts, splits, cracks deep into the cord fabric, and bulges that indicate damage to the inner ply;
- Frequent tire leaks or damage that cannot be repaired due to the size or location of the cut or other damaged areas;
- Punctures, bulges, and damage to the sidewall of the tire;
- Deformation or corrosion caused by long-term parking.

If you are not sure, please contact NIO.

### Caution

If tire wear is uneven, we recommend that you contact NIO to have the tires checked for dynamic balancing.

In order to reduce tire wear and extend the service life of your tires, you should regularly inspect and maintain your tires according to your driving habits and road conditions:

- Every tire requires a break-in period during the first 500 kilometers. You can break them in prudently at a proper speed to extend the service life of the tires.
- When driving over a curb or a similar obstacle, you should slow down and try to drive over the curb in a direction perpendicular to it.
- A violent or sharp-edged impact with a curb or an object with sharp edges (such as a rock) can cause imperceptible tire damage that will only become apparent later. Depending on the intensity of the impact, the rim flange may also be damaged.
- Sharp cornering, excessive acceleration, and abrupt braking can increase tire wear.
- When passing large potholes, speed bumps or obstacles, please slow down and be careful.
- You should have the tire dynamic balance checked after every tire replacement.
- If the vehicle can't drive straight or drifts left or right, please visit the NIO Service Center to have the wheel alignment checked and adjusted if necessary.
- The rear wheels are less worn than the front wheels. If you want to swap them, please swap the front and rear tires in the corresponding positions. We recommend that the tires be aligned every 10,000 kilometers in pairs.

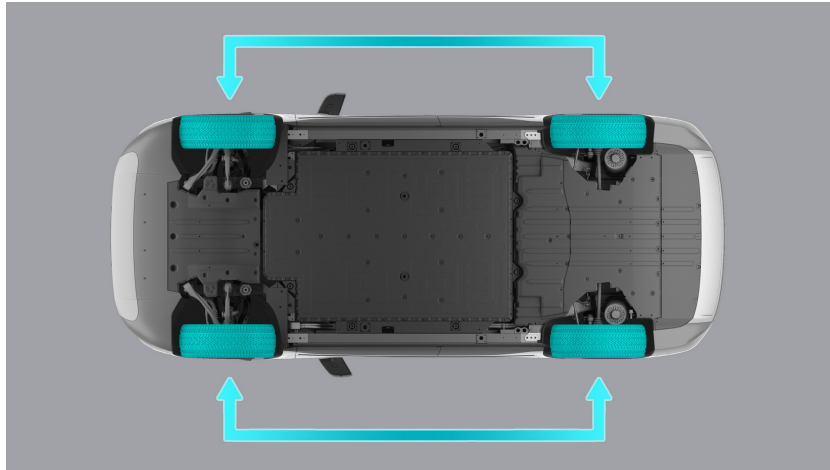

## Brake Pad and Disc Inspection and Maintenance

Lightly press the brake pedal occasionally when driving on rainy or icy roads so that the heat generated by friction warms up and dries the brake pads. The same should be done when driving in extremely wet or cold weather.

Take your vehicle for a quick ride after a car wash to dry the brake discs and avoid rusting.

The wear of brake pads and discs is largely determined by your driving habits and road conditions. The driving distance may not be used to decide the degree of wear.

The high-performance braking system is used to realize the best comprehensive braking performance at various vehicle speeds and temperatures. Therefore, under certain vehicle speeds, braking force and environments (such as temperature and humidity), the braking system may make a squeaky sound.

New or newly replaced brake pads and brake discs do not provide optimal braking performance until they are broken in by driving at least 500 kilometers. To compensate for the reduced braking effect, make sure to apply greater pressure to the brake pedal during the run-in period.

## Air Filter Inspection and Maintenance

After replacement, enter Settings from the bottom left of the center display, and tap **Cabin Comfort > Air Filter Reminder** to reset the reminder. This reminder is the estimated service life, and the actual service life may vary due to the environment and other factors. Please replace the air filter if necessary.

Keep the grille clear of any obstructions (e.g. leaves, snow) before driving.

## 12V Battery Maintenance

The 12V battery located in the trunk is mainly used to supply the 12V power sockets for the starting and electrical equipment of the vehicle. To extend the service life of the 12V battery, please keep a sufficient battery level.

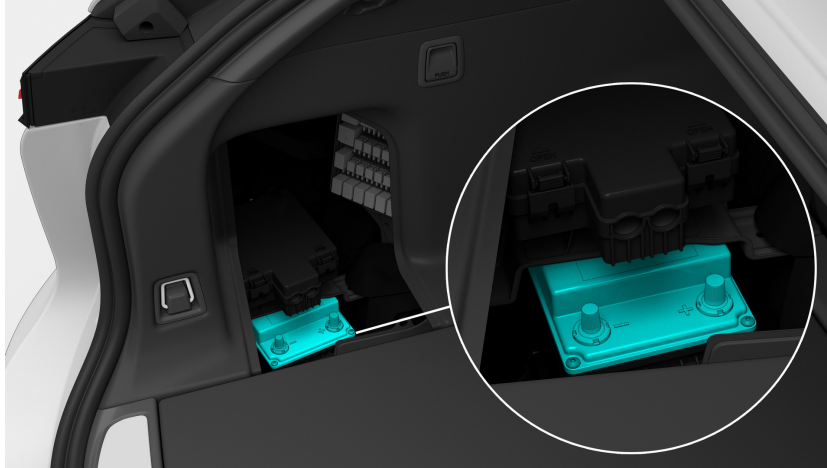

### Warning

If the 12V battery is leaking or swelling, please contact NIO immediately. If the electrolyte comes in contact with eyes or skin, please rinse the eyes or skin with running water and seek medical attention immediately.

### Caution

- If the 12V battery is severely drained (e.g. having been left unused for a long time), please contact NIO for assistance and do not replace it yourself.
- Before leaving the vehicle, please ensure that all electric systems, such as lights and the media center, are turned off, and park the vehicle in a cool and dry place.

### Caution

After disconnecting and reconnecting the 12V battery, the automatic windows and the window anti-pinch feature will not be available.

# High Voltage Battery Maintenance and Recycling

## ***High Voltage Battery Maintenance***

The high voltage battery is an important component for driving the vehicle. Please pay attention to the following when using it:

- If the vehicle is parked in an extremely hot or cold environment, the service life of the high voltage battery will be directly affected. Do not park the vehicle in such an environment for a long time (more than eight hours).
- Do not park the vehicle in a hot environment with heat sources, otherwise accidental fire may occur.
- The vehicle should be parked in a dry environment, rather than a humid environment.
- Avoid using high-power DC charging too frequently as this may affect the service life of the high voltage battery.
- If the vehicle will not be used for a long time, make sure the high voltage battery level is over 50% (according to the digital instrument cluster reading) and park the vehicle in a cool place to maintain the service life of the high voltage battery. We recommend you check the battery level every week and use the vehicle at least once a month.
- Please use charging equipment that meets the charging specifications and follow the instructions on the charger.
- When driving over bumps, gravel, or bumpy roads, please drive at a lower speed or avoid obstacles to avoid damage to the vehicle chassis or high voltage battery. If you hear any sound of scraping or impact at the underside of the body, please immediately contact NIO for a safety inspection of the chassis and high voltage battery pack.

## **Warning**

- The high voltage battery operates at a high voltage. Do not touch, move, or disassemble the high voltage battery or its circuit without authorization. Doing so may result in injury.
- Please be sure to charge the vehicle within 24 hours when the remaining driving range is at zero. During this time, the charging speed will be limited until the battery level reaches 50%. Failure to charge the vehicle within 72 hours may cause irreversible damage to the high voltage battery.



### ***High Voltage Battery Recycling***

Waste high voltage batteries should be properly recycled. In the process of vehicle maintenance and repair, high voltage batteries that meet the following conditions must be recycled:

1. In the process of high voltage battery repair and maintenance at NIO, the battery level and status will be checked. For batteries that should be recycled according to relevant laws and regulations, NIO will take primary responsibility for recycling them in accordance with the market situation at such time.
2. Batteries that are in good condition but cannot continue to be used due to other reasons can be recycled for cascading use after basic repairs.
3. Batteries that are not eligible for cascading use due to serious faults or damage will be put into the recycling process.

#### **Caution**

Do not casually dispose of the high voltage battery, as it can cause severe environmental damage.

Vehicles, vehicle parts, and batteries must be disposed of by authorized recycling companies. They must not be disposed of in general household waste or sent to landfill as this can cause severe environmental damage. Please see the NIO website for details.



This symbol on the battery means that this product must not be treated as household waste.

High voltage battery recycling process: The batteries will be recycled and disposed of by NIO or a third party designated by NIO.

## Underhood Fuse Box

### Caution

Do not use fuses with a nominal current higher than the rated current. Only replace the blown fuse with a fuse of the same nominal current and size.

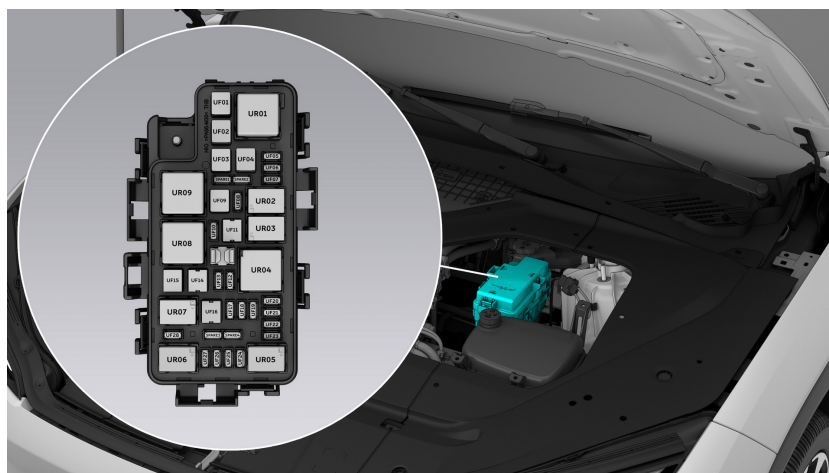

No.	Part name	Rated value	Description
UR01	UR01 relay		Cooling fan assembly (KL87 power supply)
UR02	UR02 relay		Steering column module (steering wheel heating power supply)
UR03	UR03 relay		Electronic water pump - high voltage battery (KL87 power supply)
UR04	UR04 relay		UF12/UF13/UF17/UF18/UF20/UF21/UF22/UF23/UF28 fuse power supply
UR05	UR05 relay		Horn power supply
UR06	UR06 relay		(Reserved)
UR07	UR07 relay		Electronic water pump - front

			motor (KL87 power supply)
UR08	UR08 relay		Air supply unit motor power supply
UR09	UR09 relay		Front blower (KL87 power supply)
UF01	UF01 fuse	60A	UR01 relay switch power supply
UF02	UF02 fuse	40A	Active seat belt power supply
UF03	UF03 fuse	25A	Body controller (front wiper motor) KL30 power supply
UF04	UF04 fuse		(Reserved)
UF05	UF05 fuse	10A	High voltage DC converter integrated component power supply
UF06	UF06 fuse	10A	Front inverter (KL30 power supply)
UF07	UF07 fuse	15A	UR02 relay switch power supply
UF08	UF08 fuse	10A	Charge port indicator power supply
UF09	UF09 fuse	50A	UR09 relay switch power supply
UF10	UF10 fuse		(Reserved)
UF11	UF11 fuse	20A	UR03 relay switch power supply

UF12	UF12 fuse	10A	Electronic gear selection module (KL87 power supply)
UF13	UF13 fuse	10A	Climate control/ UR09 relay coil power supply
UF14	UF14 fuse	20A	UR07 relay switch power supply
UF15	UF15 fuse	40A	UR08 relay switch power supply
UF16	UF16 fuse		(Reserved)
UF17	UF17 fuse	10A	High voltage distributor power supply
UF18	UF18 fuse	15A	Vehicle controller (KL87 power supply)
UF19	UF19 fuse		(Reserved)
UF20	UF20 fuse	10A	UR01/UR03 relay coil power supply
UF21	UF21 fuse	10A	Five-way cooling water valve (KL87 power supply)
UF22	UF22 fuse	10A	Brake switch (KL87 power supply)
UF23	UF23 fuse	10A	Front bumper movable grille (KL87 power supply)
UF24	UF24 fuse	15A	Horn power supply
UF25	UF25 fuse		(Reserved)
UF26	UF26 fuse		(Reserved)

UF27	UF27 fuse		(Reserved)
UF28	UF28 fuse	10A	UR07 relay coil power supply

## Instrument Panel Fuse Box

### Caution

Do not use fuses with a nominal current higher than the rated current. Only replace the blown fuse with a fuse of the same nominal current and size.

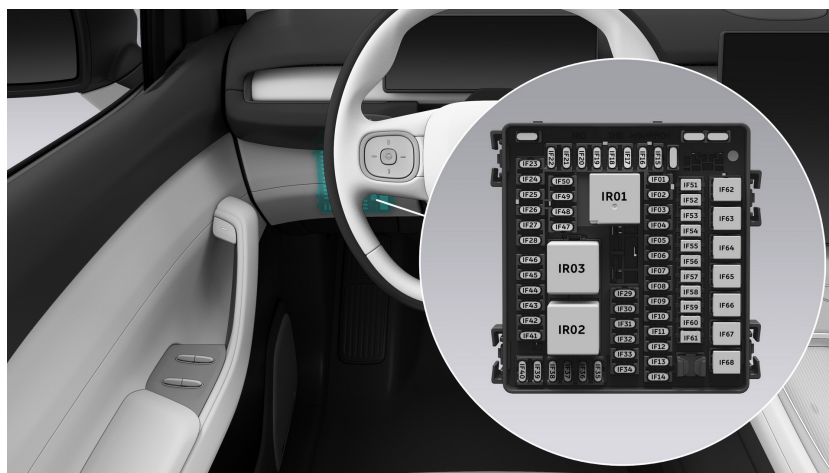

No.	Part name	Rated value	Description
IR01	IR01 relay	40A	IF29/IF30/IF31/ IF32/IF33/IF34/ IF35/IF36/IF37/ IF38/IF39/IF40 fuse (KL15 power supply)
IR02	IR02 relay	70A	IF41/IF42/IF43/ IF44/IF45/IF46 fuse (KL15 power supply)
IR03	IR03 relay	70A	IF47/IF48/IF49/ IF50 (KL15 power supply)
IF01	IF01 fuse	10A	Battery manage- ment unit (KL30 power supply)
IF02	IF02 fuse	20A	Rear feature island (KL30 power supply)
IF03	IF03 fuse	10A	Electronic gear selection module

			(KL30 power supply)
IF04	IF04 fuse	10A	Brake switch (KL30 power supply)
IF05	IF05 fuse	10A	Vehicle controller 1 (KL30 power supply)
IF06	IF06 fuse	20A	Infotainment system console 1 (KL30 power supply)
IF07	IF07 fuse	10A	Body gateway module 1 power supply
IF08	IF08 fuse	10A	Front body control module (safe box) KL30 power supply/wireless charging power supply
IF09	IF09 fuse	10A	Center display power supply
IF10	IF10 fuse	30A	ADAS main controller 1 (KL30 power supply)
IF11	IF11 fuse	10A	Smart antenna power supply
IF12	IF12 fuse	10A	Bluetooth digital key antenna module power supply
IF13	IF13 fuse	10A	Steering column power supply
IF14	IF14 fuse	10A	Heads-up display/smart robot (KL30 power supply)



IF15	IF15 fuse	10A	LiDAR sensor power supply
IF16	IF16 fuse	30A	ADAS main controller 2 (KL30 power supply)
IF17	IF17 fuse	10A	Climate control module (KL30 power supply)
IF18	IF18 fuse	10A	Exterior door handle/driver door control switch power supply
IF19	IF19 fuse	10A	IR01/IR02 relay power supply
IF20	IF20 fuse	10A	Diagnosis interface (KL30 power supply)
IF21	IF21 fuse	20A	Body controller (seat heating and backlight) KL30 power supply
IF22	IF22 fuse	10A	ETC (KL30 power supply)
IF23	IF23 fuse	15A	Body controller (washer pump) KL30 power supply
IF24	IF24 fuse	10A	Climate control module/rain & light sensor/fragrance control module power supply
IF25	IF25 fuse	20A	Body control module 1 (KL30 power supply)

IF26	IF26 fuse	20A	Body control module 2 (KL30 power supply)
IF27	IF27 fuse	10A	Digital instrument cluster (KL30 power supply)
IF28	IF28 fuse	10A	Radar/parking radar controller power supply
IF29	IF29 fuse	10A	Electric power steering power supply 1
IF30	IF30 fuse	10A	Electric power steering power supply 2
IF31	IF31 fuse	10A	Airbag controller (KL15 power supply)
IF32	IF32 fuse	10A	Body controller (KL15 power supply)
IF33	IF33 fuse	10A	Climate control module/ETC/ Rearview mirror assembly (KL15 power supply)
IF34	IF34 fuse	15A	Left headlight (KL15 power supply)
IF35	IF35 fuse	15A	Right headlight (KL15 power supply)
IF36	IF36 fuse	10A	Ambient lighting/ vanity mirror light/reading light/multi-color footwell light/ storage box light

			(KL15 power supply)
IF37	IF37 fuse	15A	Middle tailgate light (KL15 power supply)
IF38	IF38 fuse	10A	Left body taillight (KL15 power supply)
IF39	IF39 fuse	10A	Right body taillight (KL15 power supply)
IF40	IF40 fuse	10A	Front body controller KL15_1/ KL15_2 relay feedback/IR03 relay coil power supply
IF41	IF41 fuse	25A	Front 12V power socket power supply
IF42	IF42 fuse	10A	Safe box USB port power supply
IF43	IF43 fuse	10A	Front body controller power socket relay feedback
IF44	IF44 fuse	10A	Rear control panel USB port 1 (KL15 power supply)
IF45	IF45 fuse	10A	Rear seat USB power supply
IF46	IF46 fuse	25A	Rear 12V power socket power supply
IF47	IF47 fuse	10A	Driver seat pneumatic

			lumbar support power supply
IF48	IF48 fuse	10A	Passenger seat pneumatic lumbar support power supply
IF49	IF49 fuse	10A	Rear passenger massage power supply
IF50	IF50 fuse	15A	(Reserved)
IF51	IF51 fuse	15A	Body controller (charging) KL30 power supply
IF52	IF52 fuse	30A	Driver seat control power supply
IF53	IF53 fuse	30A	Passenger seat control power supply
IF54	IF54 fuse	30A	Front left door control module KL30 power supply 1
IF55	IF55 fuse	20A	Front left door control module KL30 power supply 2
IF56	IF56 fuse	30A	Front right door control module KL30 power supply 1
IF57	IF57 fuse	20A	Front right door control module KL30 power supply 2
IF58	IF58 fuse	30A	Rear left door control module

			KL30 power supply 1
IF59	IF59 fuse	20A	Rear left door control module KL30 power supply 2
IF60	IF60 fuse	30A	Rear right door control module KL30 power supply 1
IF61	IF61 fuse	20A	Rear right door control module KL30 power supply 1
IF62	IF62 fuse	40A	Brake pressure regulator motor 2 power supply
IF63	IF63 fuse	50A	IR02 relay switch power supply
IF64	IF64 fuse	40A	IR01 relay switch power supply
IF65	IF65 fuse	50A	IR03 relay switch power supply
IF66	IF66 fuse	40A	Sunroof power supply
IF67	IF67 fuse	20A	Brake pressure adjustment module power supply
IF68	IF68 fuse	40A	Brake pressure regulator motor 1 power supply

## Trunk Fuse Box

### Caution

Do not use fuses with a nominal current higher than the rated current. Only replace the blown fuse with a fuse of the same nominal current and size.

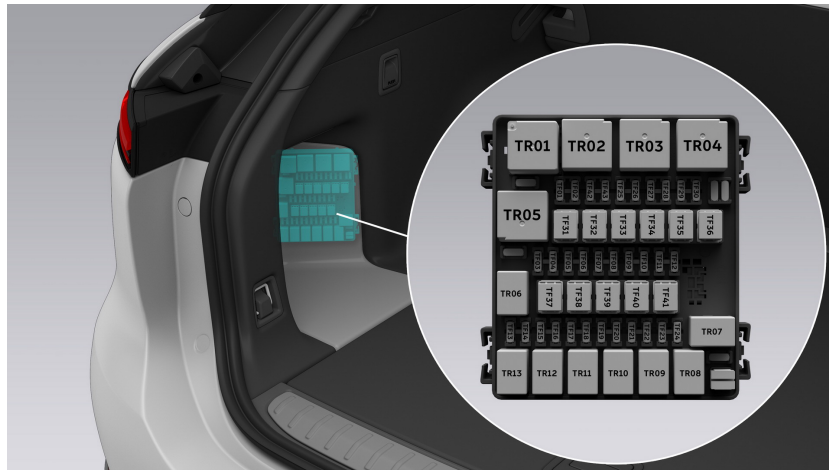

No.	Part name	Rated value	Description
TR01	TR01 relay		(Reserved)
TR02	TR02 relay	40A	Rear defogger power supply
TR03	TR03 relay	40A	KL15 power supply (redundancy)
TR04	TR04 relay		(Reserved)
TR05	TR05 relay		(Reserved)
TR06	TR06 relay		(Reserved)
TR07	TR07 relay	30A	Rear wiper power supply
TR08	TR08 relay		
TR09	TR09 relay		(Reserved)
TR10	TR10 relay		(Reserved)
TR11	TR11 relay		(Reserved)

TR12	TR12 relay		(Reserved)
TR13	TR13 relay		(Reserved)
TF01	TF01 fuse		(Reserved)
TF02	TF02 fuse		(Reserved)
TF03	TF03 fuse	10A	Battery management unit power supply 1 (KL30)
TF04	TF04 fuse	10A	Body gateway module 2 power supply
TF05	TF05 fuse	15A	Rear wiper (KL30) power supply
TF06	TF06 fuse	10A	Rear inverter power supply
TF07	TF07 fuse	10A	LiDAR sensor power supply
TF08	TF08 fuse	30A	ADAS controller 1 power supply
TF09	TF09 fuse		(Reserved)
TF10	TF10 fuse	30A	ADAS domain controller power supply 2
TF11	TF11 fuse	30A	Body controller (exterior lighting power supply) 1
TF12	TF12 fuse	30A	Body controller (exterior lighting power supply) 2
TF13	TF13 fuse	10A	Body controller power supply 2
TF14	TF14 fuse	10A	TR02 relay coil power supply

TF15	TF15 fuse	10A	Tailgate kick sensor power supply
TF16	TF16 fuse	20A	Infotainment system console (KL30 power supply) 2
TF17	TF17 fuse	15A	Pyrotechnic safety switch power supply
TF18	TF18 fuse		(Reserved)
TF19	TF19 fuse	10A	TR03 relay coil power supply
TF20	TF20 fuse		(Reserved)
TF21	TF21 fuse		(Reserved)
TF22	TF22 fuse		(Reserved)
TF23	TF23 fuse		(Reserved)
TF24	TF24 fuse		(Reserved)
TF25	TF25 fuse		(Reserved)
TF26	TF26 fuse		(Reserved)
TF27	TF27 fuse		(Reserved)
TF28	TF28 fuse		(Reserved)
TF29	TF29 fuse		(Reserved)
TF30	TF30 fuse		(Reserved)
TF31	TF31 fuse	20A	Flexible chassis controller power supply 4
TF32	TF32 fuse	30A	Rear seat power supply



TF33	TF33 fuse	30A	Amplifier control unit power supply 1
TF34	TF34 fuse	30A	Tailgate motor power supply
TF35	TF35 fuse		(Reserved)
TF36	TF36 fuse	30A	Amplifier control unit power supply 2
TF37	TF37 fuse	30A	Flexible chassis controller power supply 1
TF38	TF38 fuse	20A	Flexible chassis controller power supply 2
TF39	TF39 fuse	40A	Rear defogger power supply
TF40	TF40 fuse	40A	TR03 relay switch power supply
TF41	TF41 fuse	20A	Flexible chassis controller power supply 3

## Pre-Fuse Box

### Caution

Do not use fuses with a nominal current higher than the rated current. Only replace the blown fuse with a fuse of the same nominal current and size.

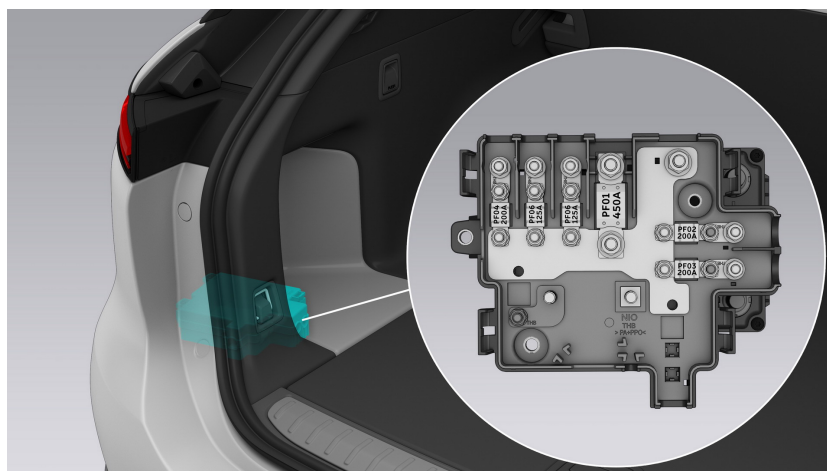

No.	Rated value	Description
PF01	450A	DC/DC converter
PF02	200A	Underhood electrical box
PF03	200A	Instrument panel fuse box
PF04	200A	Trunk Fuse Box
PF05	125A	Electric power steering gear
PF06	125A	Electric power steering gear

## Exterior Cleaning and Maintenance

Regular cleaning and waxing can protect the vehicle exterior from damage from the external environment. The frequency of cleaning and waxing depends on the frequency of use, parking conditions (whether the vehicle is parked in a garage, under a tree, or in direct sunlight), and weather conditions.

Bird droppings, insect residues, tree resins, industrial emissions, tar spots, cinders, and other deposits on the body and roof will cause damage to the paint. Such corrosion intensifies at high temperatures and in strong sunlight. Therefore, a weekly cleaning may be necessary. Wet the stains with sufficient water and then remove them.

### Warning

Do not wash the vehicle when it is in charging.

### Caution

Please use specialized cleaners or conditioners when washing or waxing the vehicle. Pay attention to the expiry date before use and keep out of reach of children.

### ***Manual Cleaning***

When cleaning the vehicle manually, use sufficient water to wet the vehicle exterior and rinse away as many stains as possible. Use a soft sponge, cloth, or soft brush to carefully clean the vehicle from top to bottom. Use cleaners to remove stubborn stains. When the sponge or cloth gets too dirty, replace it. After cleaning the vehicle, rinse it thoroughly with clean water and wipe it with a towel. After salt spreading in winter, clean the underside of the vehicle thoroughly.

In order to protect the environment, please clean the vehicle on a specialized cleaning platform. If such equipment is not available, please choose a proper place to clean the vehicle.

### Note

- Do not wash the vehicle under direct sunlight as this may cause damage to the paint.
- When washing the vehicle with a water hose in cold weather, do not spray water directly on the door handles, charge ports, doors and sunroof. Otherwise, these moving parts may freeze in place.

- Do not use rough sponges or corrosive cleaners which may damage the paint.
- Do not use water hotter than 60°C.
- Do not use a dry cloth or sponge to clean the headlights. Clean them with water or car shampoo instead.

### ***Automatic Cleaning***

The vehicle can be cleaned in an automatic car wash, but the structure, filter, and the type of cleaners and conditioners of the car wash equipment will affect the exterior paint. If the body paint looks dull or scratched after a car wash, please inform the car wash operator immediately. If necessary, the car wash equipment should be replaced.

Before using an automatic car wash, the windows and sunroof should be closed, the auto wiper feature disabled, and the side mirrors folded. At the same time, the car wash operator should be notified that the vehicle is equipped with roof racks and a radio antenna.

### **Caution**

Please shift into NEUTRAL (N gear) before an automatic car wash. Enter Settings from the bottom of the center display, and tap **Driving > Tow/Wash Mode**.

### ***High Pressure Cleaning***

When using a pressure washer, be sure to follow the operating instructions and maintain a sufficient distance from paint surface or soft materials (such as rubber hoses or sound insulation materials). When washing the vehicle, it is recommended to keep a distance of more than 500 mm at a pressure below 100 bar and a temperature not higher than 60°C and keep the washer as perpendicular as possible to the vehicle. Exceeding these standard parameters may cause damage to vehicle parts or water dripping into the car.

Do not use round beam nozzles or rotary nozzles. Tires must not be cleaned with round beam nozzles. Even if used from a distance and for a short time, such a nozzle may cause damage to the tires.

Do not use a pressure washer to flush the vehicle certification label or the corners of the window glass.

### ***Polishing and Waxing***

High-quality wax protects the vehicle paint from environmental damage and even prevents minor scratches. When water drops no longer roll off smoothly from the clean body paint, use a layer of high-quality hard car wax on the body paint. If the vehicle is cleaned regularly with cleaners, we recommend you apply hard wax at least twice a year to protect the body paint.

Polishing is only necessary when the body paint surface has lost its gloss and cannot be restored by waxing. Do not polish plastic parts or parts with matte finish.

### ***Wiper Blades***

Wash wiper blades with lukewarm car shampoo. Do not use alcohol or cleaners that contain petroleum products.

### ***Windows and Side Mirrors***

Use glass cleaners to regularly clean the inside and outside of all windows.

Clean the inside of the rear windshield with a soft cloth by wiping transversely. Do not scrape the glass or use abrasive cleaners to avoid damaging the heating element.

Clean the side mirrors with car shampoo. Do not use abrasive cleaners to avoid damaging the mirrors.

### ***Plastic Parts***

Clean the plastic parts with common cleaning methods. For stubborn stains, only use specialized solvent-free plastic cleaners to avoid corrosion.

### ***Chrome Parts***

You can clean the chrome parts with a wet cloth first and then wipe them with a soft dry cloth. For a better effect, use chrome conditioners to clean the chrome parts. When using chrome conditioners, be sure to apply the products completely and evenly. Do not clean or wipe the chrome parts in dusty or sandy environments.

### ***Wheels***

To keep the aluminum alloy wheels in good condition, the wheels require regular maintenance. We recommend you clean them thoroughly once every two weeks to prevent abrasive particles, dirt, or salt particles from attaching to and corroding the wheels. After cleaning, treat the aluminum alloy wheels with specialized acid-free and alkali-free cleaners. Apply hard wax on the wheels once every three

months. If the protective paint layer is damaged due to impact, such as from a stone, be sure to retouch the paint immediately. Do not use paint polish or other polishing materials.

Serious stains on the wheels can cause imbalance of the wheels. This will result in wheel vibrations, which will be transmitted to the steering wheel. In some cases, this can cause premature wear on the steering mechanism. Therefore, it is necessary to regularly clean stains on the wheels.

### ***Underbody Protection***

The underbody of the vehicle is specially treated to protect against chemical and mechanical damage. However, damage to the protective layer during driving is inevitable. It is recommended to check the underbody and the protective layer before winter and in spring on a regular basis and repairing it when necessary.

### ***Exposed Area of Radar***

You can manually clean the exposed area of the radar by wiping it with a flannel soaked with an appropriate amount of water or neutral cleaning solution.

Where there is snow or ice, please remove the ice and snow on the exposed area of the radar first, and then wipe it with a flannel or let it dry in the air.

When using a pressure washer, please do not directly flush the exposed area of the radar. Otherwise, damage may occur.

Be careful not to contaminate or damage the sensors on the front/rear bumpers during maintenance.

Do not film, wax or coat the exposed area of the LiDAR sensor. Otherwise, the LiDAR sensor performance may be impaired.

## Interior Cleaning and Maintenance

Regularly clean the interior with cleaners or conditioners to maintain the interior appearance. Before using any cleaners, vacuum the interior first.

### Note

- Some dyes (such as from dark-washed jeans or sheepskin clothing) may stain the interior materials. When this happens, clean the stained surface as soon as possible.
- Do not use strong solvents such as cleaning fluids, petrol or petroleum solvents which may damage the interior materials.
- Do not spray cleaners directly on electronic buttons, switches or parts. Wipe stains with a soft cloth dampened with cleaning fluid.
- Sharp objects may damage the fabric interior.

### ***Fabric Interior***

Only use specialized cleaners, dry foam, and a soft brush to clean the fabric materials on the doors, rear trunk, roof, and other areas.

### ***Leather Interior***

You can use a slightly wet cotton or woolen cloth, or a cleaning cloth to clean common dirt on the leather interior. You can use a cloth dipped in mild car shampoo to clean stubborn oil stains. Make sure that the leather material is not fully wet and prevent water from seeping through the stitching. Any remaining water on the leather surface should be quickly wiped off with a soft dry cloth. Stains from ballpoint pens, ink, lipsticks, shoe polish, and other substances on leather surfaces should be removed as soon as possible. We recommend you use a 100% pure polyurethane foam sponge for cleaning Nappa leather.

We recommend limiting the use of leather care products as much as possible, no more than twice a year for light-colored leather and no more than once a year for dark-colored leather.

### Note

- Do not use cleaning solvents to clean the instrument panel, air bag covers, or leather interior.
- To avoid leather fading, do not leave the vehicle under strong sunlight for long periods of time. If you need to park the vehicle under strong sunlight, please cover all leather material.

- Sharp objects on clothes such as zips, rivets, and sharp buckles may leave marks or dents on the leather.
- Avoid drinking coffee or using sunscreen in vehicles with a Nappa leather interior. Remove coffee or sunscreen stains on Nappa leather with mild soapy water as soon as possible.
- Do not spray formaldehyde cleaners on leather. Doing so may leave white spots on genuine leather which are difficult to remove.

### ***Seat Belts***

Only use mild car shampoo to clean the seat belts. Do not remove the seat belts from the vehicle. Allow the belts to dry fully while extended.



## Application of Antibacterial Product

### ***Haptex***

Haptex synthetic leather with antibacterial properties by means of a functional layer is based on Biomaster AT300 (active ingredient silver chloride CAS-Nr. 7783-90-6) for use in automotive interior parts (e.g. seats, IP, CNSL, and pillars) cladding: Antimicrobial product protection against gram-positive and gram-negative bacteria (e.g. Staphylococcus aureus and Escherichia coli according to GB/T 31402 or ISO 22196). No additional precautions need to be taken when the driver and passengers use the vehicle normally.

### ***PVC***

PVC synthetic leather with antibacterial properties is based on SILVADUR™ 960 Flex Antimicrobial, a polymeric system incorporating a silver ion antimicrobial agent (active ingredient CAS-Nr. 7761-88-8) for use in automotive interior part (e.g. IP upper, DP top roll, console inner) cladding: Antimicrobial product protection against gram-positive and gram-negative bacteria (e.g. Staphylococcus aureus and Escherichia coli according to ISO 22196). No additional precautions need to be taken when the driver and passengers use the vehicle normally.

### ***Paint***

1. Akzo Nobel waterborne coatings with antibacterial properties are based on silver chloride (active ingredient CAS-Nr. 7783-90-6) for use in the driver airbag cover: Antimicrobial product protection against gram-positive and gram-negative bacteria (e.g. Staphylococcus aureus and Escherichia coli according to GB/T 31402 or ISO 22196). No additional precautions need to be taken when the driver and passenger use the vehicle normally.
2. MUSASHI coatings with antibacterial properties are based on silver phosphate glass (active ingredient CAS-Nr. 308069-39-8) for use in the garnish ASSY of the steering wheel: Antimicrobial product protection against gram-positive and gram-negative bacteria (e.g. Staphylococcus aureus and Escherichia coli according to GB/T 31402). No additional precautions need to be taken when the driver and passenger use the vehicle normally.
3. PETER coatings with antibacterial properties are based on silver phosphate glass (active ingredient CAS-Nr. 308069-39-8) for use in automotive interior parts (e.g. door handle Inlay, rear air vent panel, rear USB panel, and PRND ornament): Antimicrobial product protection against gram-positive and gram-negative bacteria (e.g. Staphylococcus aureus and Escherichia coli according

to ISO 22196). No additional precautions need to be taken when the driver and passenger use the vehicle normally.

### ***Steering Wheel Leather***

Artificial leather with antibacterial properties by means of a functional layer is based on Laedana<sup>®</sup> (active ingredient silver adsorbed on silicon dioxide as a nanomaterial in the form of a stable aggregate with primary particles in the nanoscale) for use in the steering wheel surface cover: Antimicrobial product protection against gram-positive and gram-negative bacteria (e.g. Staphylococcus aureus and Escherichia coli according to GB/T 31402 or ISO 22196). No additional precautions need to be taken when the driver and passengers use the vehicle normally.

### ***Filter***

Filter with antibacterial properties by means of a functional layer is based on dimethyltetradecyl[3-(trimethoxysilyl)propyl]ammonium chloride (N-46279) (active ingredient CAS-Nr. 41591-87-1) for use in air handling/air conditioning systems: Bacteriostatic and fungistatic properties against a multitude of gram-positive and gram-negative bacteria, yeast, and fungi according ISO 846 and JIS L 1902. No additional precautions need to be taken when placing the filter on the market.

### ***Evaporator Core & Inner Condenser Coating***

URD Coating is a hydrophilic chemical that contains biocidal products. The evaporator and IC could be protected by the hydrophilic coating, with antimicrobial properties by means of a functional layer based on active substances TBZ (CAS:148-79-8), SPT (CAS:3811-73-2), ZPT (CAS:13463-41-7), and/or OIT (CAS:26530-20-1). The coating shows great antimildew properties for Aspergillus Niger, Penicillium sp., and antibacterial properties for Escherichia coli and Staphylococcus aureus according to GB 21551.2. No additional precautions need to be taken when placing the evaporator and inner condenser on the market.

## Vehicle Info

Vehicle manufacturer	Anhui Jianghuai Automobile Group Corp., Ltd.
NIO hotline	Refer to the contact table
NIO official website	Refer to the contact table

You can find the vehicle certification label in the lower area of the right B-pillar.

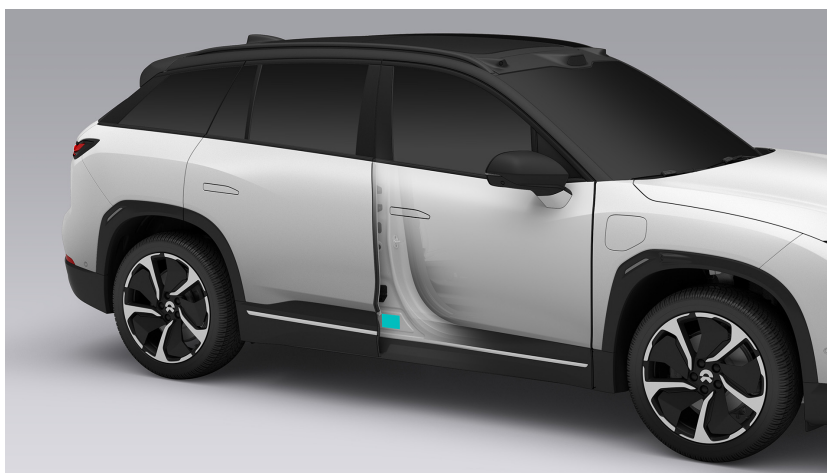

Vehicle brand label:

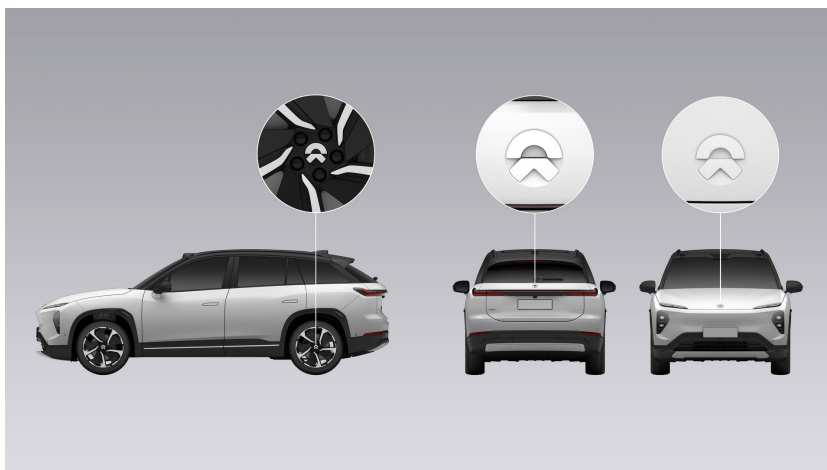

## Instrument Cluster and Controls

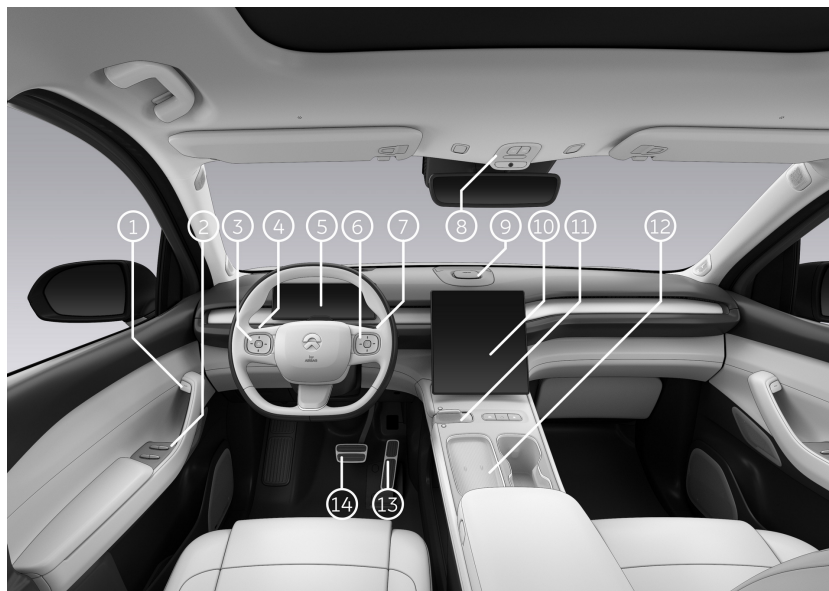
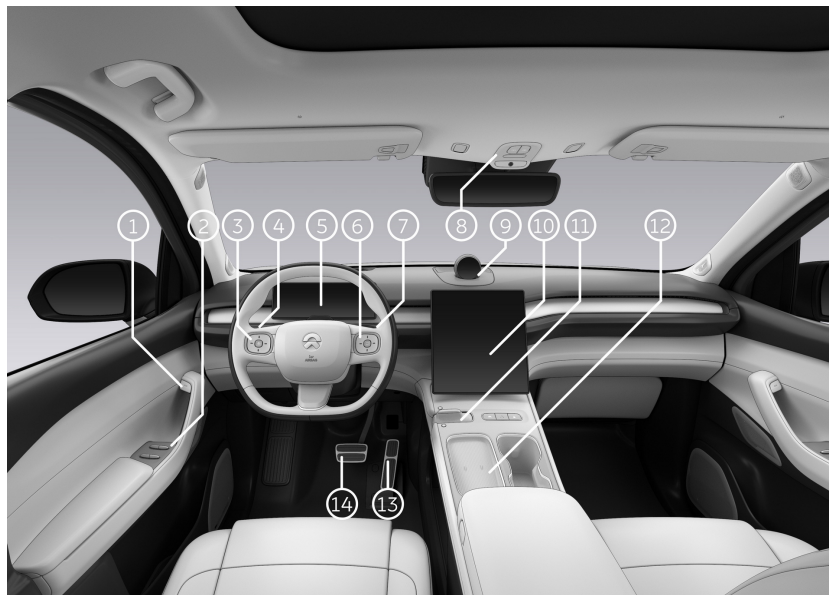

1. Electronic switches on interior door handles

2. Control panel for windows

3. Steering wheel buttons - left

4. Light control lever for turn signals and headlights

5. Digital instrument cluster

6. Steering wheel buttons - right

7. Wiper and washer control lever

8. Control panel for emergency calls and reading lights

9. NOMI

10. Center display







11. Gear selector and center console control panel

12. Wireless charging pad

13. Accelerator pedal

14. Brake pedal

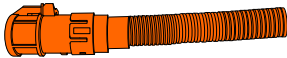
## Warning Sign Information

No.	Name	Warning Sign	Description
1	High voltage electricity warning sign		Danger! Do not touch high voltage components.
2	High voltage component warning sign 1		High voltage components. Danger! Do not touch high voltage components without wearing protective equipment to avoid electric shock.
3	High voltage component warning sign 2		High voltage components. Danger! Do not touch high voltage components without wearing protective equipment to avoid electric shock and burns.
4	High voltage battery pack warning sign		Cautions for using the high voltage battery pack
5	High voltage cable warning sign		High voltage components are connected with orange high voltage harnesses. Do not touch high voltage components without wearing protective equipment.
6	Mutual compatibility identifiers used for charging the car		Mutual compatibility identifiers to guide you charging the car are found in the car's charging port. When selecting the charging gun, you must make sure the identifier on the charging gun equals one of

			<p>the identifiers found in the car's charging port, either C, K or L. Voltage ranges related to those identifiers are as follows:</p> <ul style="list-style-type: none"><li>• C: AC <math>\leq</math> 480V</li><li>• K: DC 50V to 500V</li><li>• L: DC 200V to 920V</li></ul>
--	--	--	--

## Vehicle Identification Number (VIN)

The vehicle identification number (VIN) is stamped on the right of the hood.

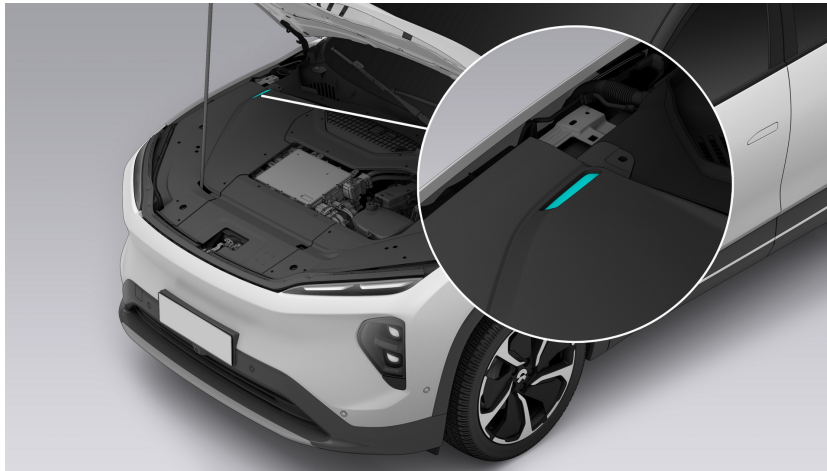

You can also find the VIN in the following locations:

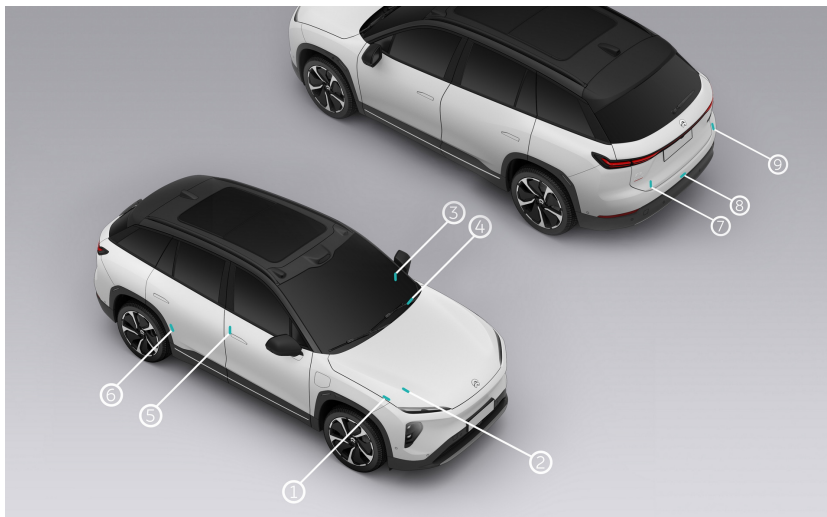

1. Underside of the hood
2. Upper area at the end of the front driving motor
3. Left side of the instrument panel beam
4. Lower-left area of the front windshield
5. Lower area of the right B-pillar
6. Lower area of the right rear door frame
7. Upper area at the end of the rear motor
8. Upper side of the rear floor
9. Right side of the tailgate

You can also read the VIN from diagnostic instruments that pair with the vehicle (safety module diagnosis tool BD2):

1. Connect the diagnostic instrument to the diagnostic interface of the vehicle and turn it on.

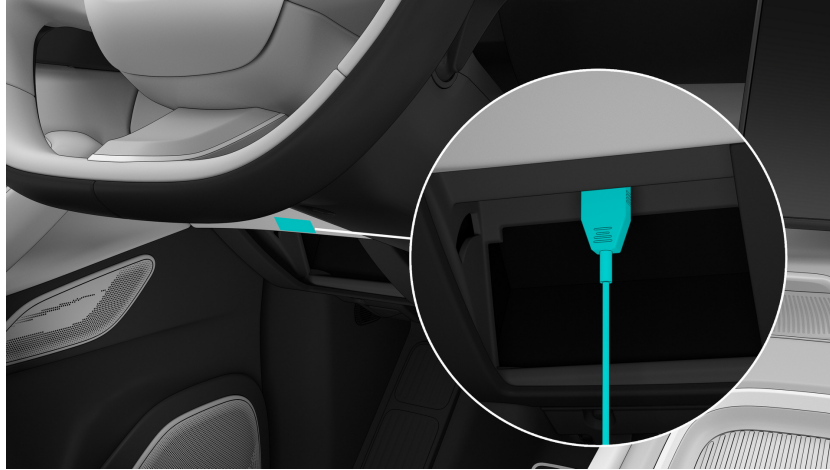

2. Start the diagnostic program and log in to the diagnostic instrument interface.
3. The diagnostic instrument automatically reads and displays the VIN on the interface of the diagnostic instrument.

There is a radio frequency identification device (RFID) at the front windshield of the vehicle. You can install your ETC device here.

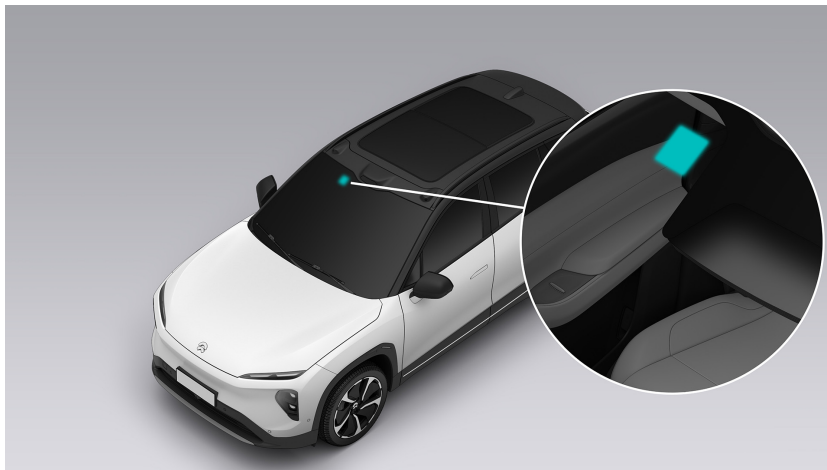



## Driving Motor Identification Labels

The front driving motor identification label is located on the lower side of the motor.

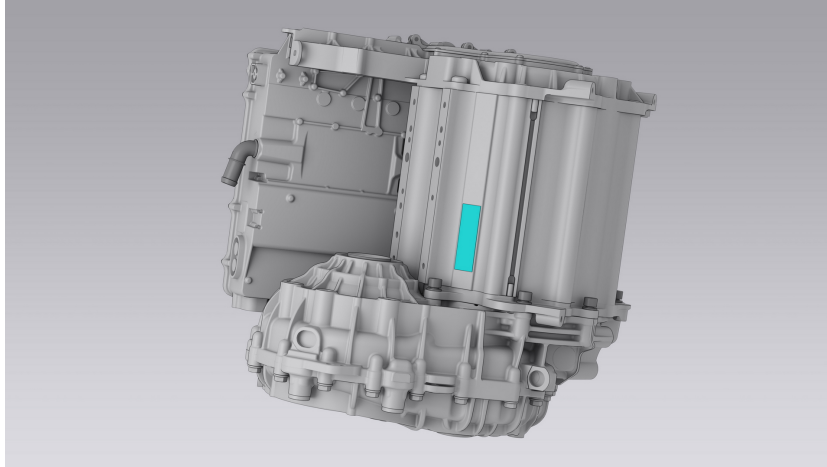

The rear driving motor identification label is located on the lower side of the motor.

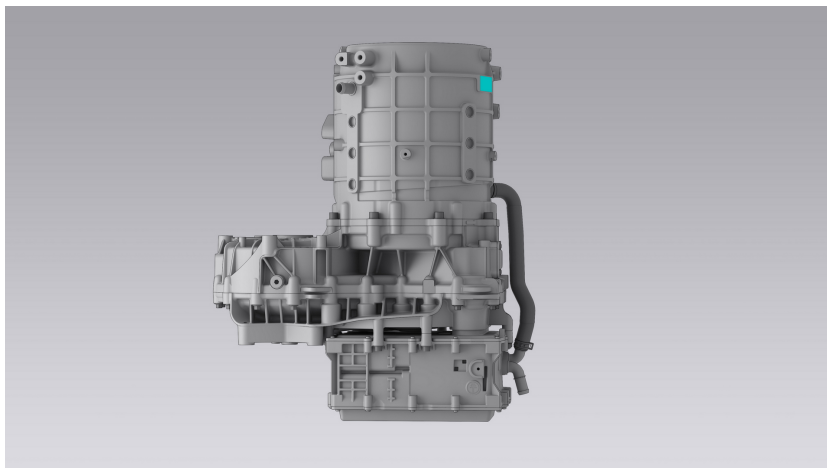

## Recommended Fluids and Capacities

Item	Product	Capacity
Brake Fluid	DOT4	0.71L
Coolant	-40°C OAT (water-ethylene glycol solution containing inhibitor)	14.75L (75 kWh) 14.5L (100 kWh)
Refrigerant	R1234yf	1000g
Windshield Washer Fluid	Freezing point<-30°C	3L
Gearbox Oil	Castrol BOT350M3	1L (front), 1.6L (rear)

## Powertrain Information

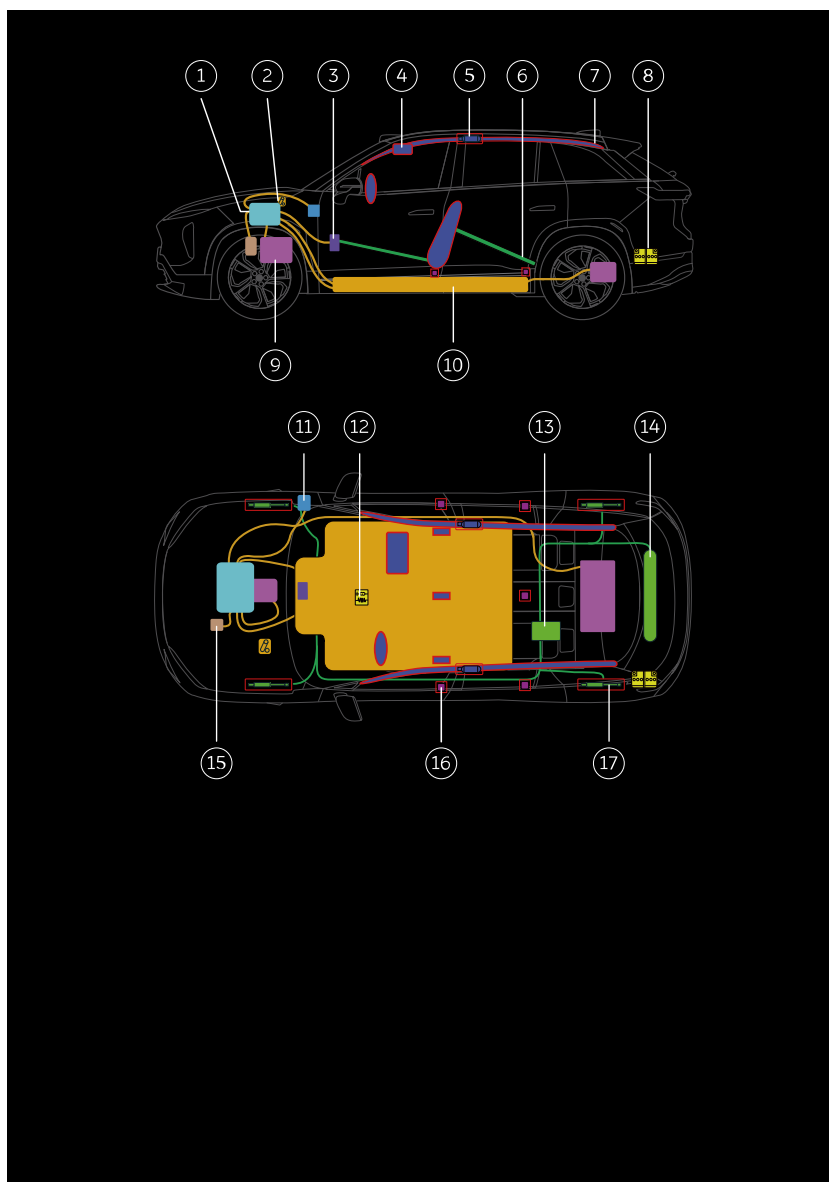

1. High Voltage Control System
2. Emergency High Voltage Cutoff Plug
3. High Voltage Heater for Climate Control
4. Airbags
5. Curtain Airbag Cylinder
6. Structural Reinforcement
7. Curtain Airbags
8. 12V Battery
9. Driving Motor
10. High Voltage Battery
11. Charge Port
12. Airbag Control Unit
13. High Pressure Air Pump
14. High Pressure Air Tank
15. A/C Compressor
16. Seat Belt Pretensioner Mechanism
17. Air Suspension

### ***High Voltage Battery***

The vehicle is equipped with a 350V lithium-ion high voltage battery. Do not damage it when lifting from under the vehicle. When using rescue tools, please take special care to avoid breaking the underbody.

### **Warning**

- Before servicing, removing and installing high voltage components, be sure to power off the vehicle and confirm that the emergency power-off switch and 12V power supply are disconnected. After the vehicle is powered off, let it sit for more than 5 minutes.
- No personnel without corresponding qualifications shall operate high voltage components. Operators must wear protective equipment such as insulating gloves that meet related requirements, and must not carry any metal objects.

***Driving Motor***

The driving system powers the vehicle by converting the direct current from the high voltage battery into mechanical torque which is distributed to the four wheels. In addition, it can also recover kinetic energy to charge the high voltage battery and operate to turn the drive shafts backward. The driving system consists of two driving motors. The front motor is mounted on the front subframe, and the rear motor is mounted on the rear subframe.

***12V Battery***

The 12V battery powers the Supplemental Restraint System, windows, locks, touchscreen, and vehicle lighting.

***Airbags***

The airbag system includes front airbags and side airbags. Front airbags include front head airbags, located in the trim flap of the steering wheel and on the headliner of the passenger side. Side airbags include a seat-mounted side airbag in the front driver (located on the outside of the front seats) and a curtain airbag (located above the doors on both sides, in the roof area from A-pillar to C-pillar, containing the curtain cylinders). The presence of an airbag is indicated by the word "AIRBAG" in all places where the airbag is located.

***Air Suspension High Pressure Tank***

The high-pressure air tank is mounted at the rear of the vehicle body using a rubber-wrapped bracket. The air tank generates sufficient air for the suspension system. The ride height is adjusted by adjusting the air pressure of the system.

## Vehicle Dimensions

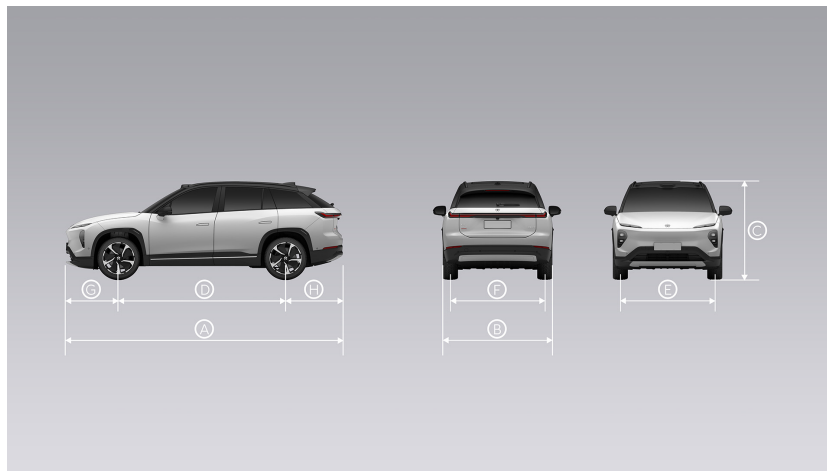

Item	Value
Length A (mm)	4912
Width B (mm) (excluding side mirrors)	1987
Height C (mm)	1720
Wheel Base D (mm)	2960
Front Track E (mm)	1668
Rear Track F (mm)	1672
Front Overhang G (mm)	935
Rear Overhang H (mm)	1017
Ground Clearance (mm)	158
Approach Angle	17°
Departure Angle	22°
Seats	5

## Mass Parameters

Item		75 kWh	100 kWh
Unladen mass (kg)		2346	2366
Mass of vehicle with bodywork in running order (including coolant, oils, fuel, tools, spare wheel and driver) (kg)		2421	2441
Distribution of this mass among the axles (kg)	Front Axle:	1216	1226
	Rear Axle:	1205	1215
Technically permissible maximum laden mass stated by the manufacturer (kg)		2890	2890
Distribution of this mass among the axles and, in the case of a semi-trailer or centre-axle trailer, load on the coupling point (kg)	Front Axle:	1306	1306
	Rear Axle:	1584	1584
Technically permissible maximum mass on each axle (kg)	Front Axle:	1400	1400
	Rear Axle:	1695	1695

### Caution

When a trailer is installed, it's still necessary to ensure that:

- Technically permissible maximum laden mass no more than 2890 kg;
- Technically permissible maximum mass on Front Axle no more than 1400kg, and on Rear Axle no more than 1695kg.



## Wheel and Tire Specifications

Item	Value
Specifications	255/50R20 109V XL
	265/45R21 108Y XL
Tire Pressure (bar)	2.6 (no load)
Camber Angle	$-0.5 \pm 0.5^\circ$
Total Front Camber Angle	$0 \pm 0.5^\circ$
Front Toe Angle	$0.3 \pm 0.2^\circ$
Front Caster Angle	$4.7 \pm 0.5^\circ$
Total Front Caster Angle	$0 \pm 0.5^\circ$
Rear Camber Angle	$-1.3 \pm 0.5^\circ$
Total Rear Camber Angle	$0 \pm 0.5^\circ$
Total Rear Toe Angle	$0.2 \pm 0.2^\circ$
Approach Angle	$0 \pm 0.2^\circ$
Steering Wheel Angle	$0 \pm 3.5^\circ$
Front Track Height (mm)	$473 \pm 5$
Rear Track Height (mm)	$476 \pm 5$
Lug Nut Torque (N·m)	210

Note: Wheel specifications are subject to the vehicle configurations.

### ***Tire Marks***

The tire sidewalls are marked with all tire-related signs and features.

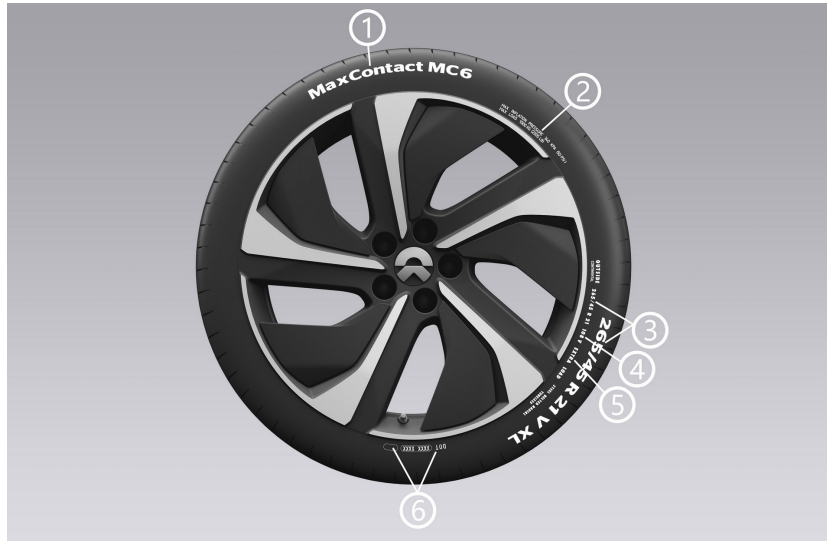

1. Product name
2. Maximum tire load and maximum allowable inflation pressure (which should not be used for normal driving)
3. Tire Size  
For example, 245/45R20 means that the tire width is 245 mm and the aspect ratio is 45, R refers to the radial structure of the tire, and the wheel diameter is 20 inches.
4. Tire load index and rated speed  
For example, 103 means that the tire load is 875 kg, 105 means that the tire load is 925kg.  
Rated speed refers to the maximum speed at which the tire can operate for a long time, where Q=160 km/h, R=170 km/h, S=180 km/h, T=190 km/h, U=200 km/h, H=210 km/h, V=240 km/h, W=270 km/h, and Y=300 km/h.
5. Rated load mark
6. DOT tire identification number  
After the letters DOT, the first 2 digits/letters represent the code of the factory where the tire was manufactured, the next 2 digits/letters represent the size of the tire, the next 4 digits/letters represent the type code of the tire, and the last 4 digits represent the year and the week when the tire was manufactured. For example, 1721 represents the 17th week of 2021. This information can be used to contact the consumer when a tire is defective and needs to be recalled.

## Motor Parameters

Item	Value	
	Front	Rear
Type	Permanent magnet alternating current motor	Alternating current induction motor
Model	TZ180S001	YS300S002
Rated power/torque (kW/ N·m)	70/150	35/70
Peak power/torque (kW/ N·m)	180/350	300/500

## Braking and Suspension Specifications

Item	Value	
Brake Pad Thickness (mm)	Front	Rear
	2-9	2-11
Brake Disc Thickness (mm)	Front	Rear
	32-30	20-18
Nominal Pressure of Air Suspension Reservoir (bar)	20	

## High Voltage Battery Parameters

Item		100 kWh (Jiangsu Contemporary Amperex Technology Limited)	100 kWh (CALB Co., Ltd.)	75 kWh	70 kWh
High voltage battery cell	Type	Ternary lithium ion battery	Ternary lithium ion battery	Ternary lithium ion/ lithium iron phosphate battery	Ternary lithium ion battery
	Rated voltage (V)	3.73	3.74	3.73/3.22	3.65
	Rated capacity (Ah)	276	137	237/192	100
High voltage battery pack system	Rated voltage (V)	358	358	386	350
	Rated capacity (Ah)	280	280	195	200
	L x W x H (mm)	2062 x 1539 x 185.6	2062 x 1539 x 183.1	2062 x 1539 x 185.6	2062 x 1539 x 185.6
	Number of cells in battery pack	96	192	118	192
	Weight of battery pack (kg)	555	555	535	525

## Tire Inflation

### Warning

Using underinflated or overinflated tires will increase the risk of accident and injury.

To ensure your safety while driving, please check the tire pressure regularly. When checking the tire pressure, make sure the tires are cold (the tire temperature is the same as the ambient temperature or the vehicle has not been moved for three hours after driving). The recommended cold tire inflation pressure label is located on the frame of the driver door. If the tire is hot, the tire pressure is generally 0.3 bar higher than that of a cold tire.

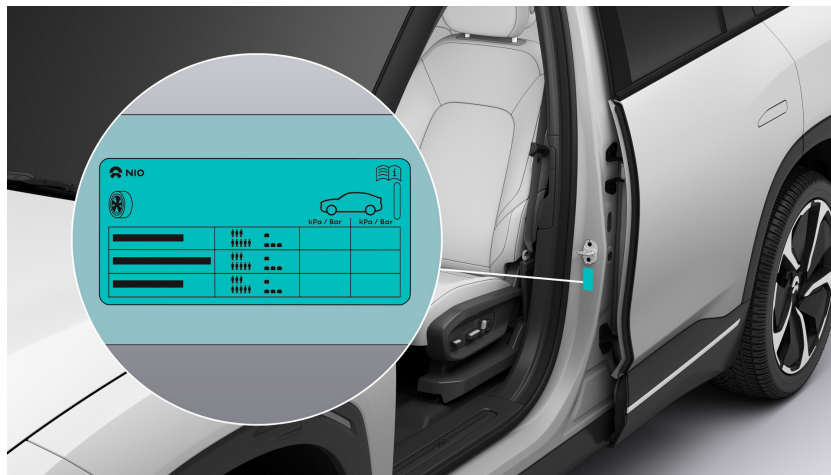

Overinflation will affect your comfort while driving, damage tires, especially on rough roads, and cause blowouts in severe cases. This may lead to unexpected loss of vehicle control and an increased risk of injury. Underinflation will cause uneven tire wear, affect vehicle handling, and result in abnormal energy consumption.

### Note

The 21-inch tires are self-sealing tires. When the width of a tire puncture is less than 5 mm and the tire pressure shown on the center display is normal, the vehicle can still be driven under 120 km/h. If the tire is severely punctured or damaged, please contact NIO immediately for tire inspection or replacement.

You can inflate the tires with the tire inflator in the emergency kit. To inflate a flat tire:

1. Park the vehicle on a safe road, put on the reflective vest and set up the warning triangle properly.
2. Open the emergency kit cover in the trunk to take out the tire inflator.



3. Connect the inflation hose on the side of the tire inflator to the valve stem on the tire.

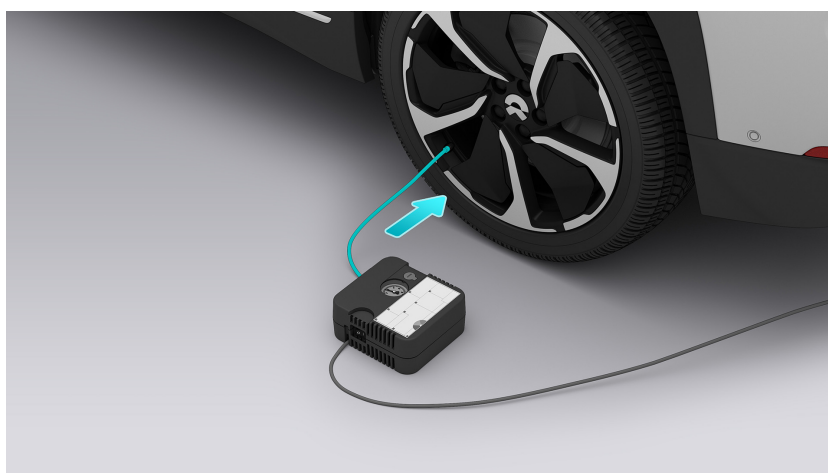

4. Connect the power plug of the tire inflator to the 12V power socket in the vehicle.

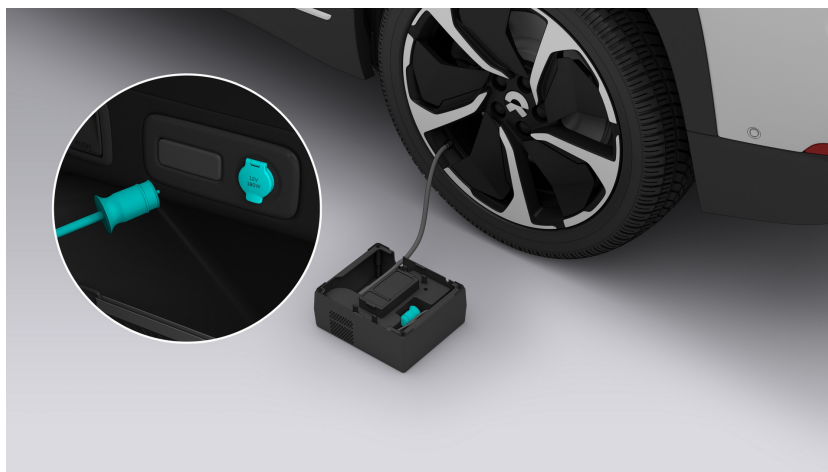

5. Make sure the vehicle is powered on, turn on the power switch of the tire inflator, and inflate the tire. When the tire pressure reaches 2.6 bar, turn off the tire inflator manually and disconnect it from the power socket.

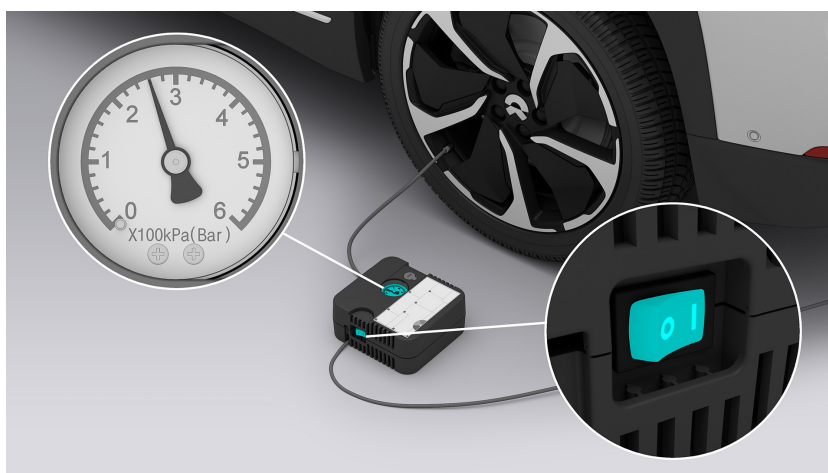



6. After completing inflation, disconnect the inflator from the vehicle and stow it in the emergency kit.



## Tire Pressure Monitoring System (TPMS)

The vehicle is equipped with a Tire Pressure Monitoring System. If one or more tires have an abnormal pressure or temperature, the digital instrument cluster will light up the tire pressure indicator  and display the location of the faulty tire. It will also remind you to stop driving and check the tire as soon as possible and inflate or deflate the tire to the normal range.

If a tire has an abnormal tire pressure or is deflating rapidly, the instrument cluster will light up the tire pressure indicator  and the system will emit a beep to remind you to check the tire pressure. If the system functions abnormally or the tire temperature is above the rated range, the indicator will flash for 75 seconds and then stay solid , and the system will emit a beep to remind you. In this case, park the vehicle in a safe place as soon as possible and contact NIO.

You can tap **My EL7 > Health** on the center display to check the current tire pressure detected by the pressure monitoring system. If the current tire pressure is shown as "--", this means the system has not obtained a valid tire pressure reading, and you can check the tire pressure again after driving over 25 km/h for more than 10 minutes. If a tire is underinflated, overheated, or has any other abnormality detected by the system, the center display will highlight the position of the faulty tire and display the detailed fault information.

The Tire Pressure Monitoring System is based on the tire temperature and atmospheric temperature. At high altitudes or low temperatures, it may be necessary to inflate the tire to a slightly higher pressure to eliminate the low tire pressure alarm.

The operation of the pressure monitoring system may be disrupted if radio transmitting devices (e.g. wireless headphones, walkie-talkies) are used in or near the vehicle.

## Tire Chains

The vehicle does not come with tire chains, but you can purchase them. Please pay attention to the following points when using tire chains:

- Improper tire chains can damage the tires, wheels, and brake system of the vehicle. Please carefully check the specifications of the original equipment (OE) tires and the relevant instructions provided by the tire chain manufacturer. Only the rear 20-inch original equipment (OE) tires are suitable for tire chains. Tire chains are not recommended on other tires.
- Do not drive over 50 km/h or the speed limit specified by the tire chain manufacturer (whichever is lower).
- Drive carefully and slowly to avoid bumps, potholes, sharp turns, or wheel lock-up, which may impair the functionality of or cause damage to the vehicle.
- To avoid tire damage and excessive tread wear, tire chains must be removed when driving on roads without snow.

## AutoSock

The vehicle does not come with AutoSock, but you can purchase them separately. Please pay attention to the following points when using AutoSock:

- Improper AutoSock can damage the tires, wheels, and brake system of the vehicle. Please carefully check the specifications of the original equipment (OE) tires and the relevant instructions provided by the AutoSock manufacturer. AutoSock can be used on all the four wheels of the vehicle.
- AutoSock is only used on ice and snow. When driving onto dry roads (asphalt roads, cement roads, dirt roads, etc.), remove it immediately. AutoSock should be removed when the vehicle is parked.
- When the vehicle starts, ice and snow particles on the ground may be thrown up due to the increased grip of AutoSock. Avoid standing at the rear of the vehicle.
- No need to turn off the vehicle's electronic stability system when AutoSock is in use.
- The speed of the vehicle must not exceed 50 km/h with AutoSock installed. Please also avoid sharp acceleration, braking, turning, and other aggressive operations, otherwise, there is a high risk of damage to AutoSock.
- If any abnormal noise is heard during driving with AutoSock installed, stop the vehicle in a safe position and, while ensuring personal safety, check whether AutoSock is installed correctly.
- When the black fabric in the bottom layer below the white road contact fabric is exposed, stop using AutoSock, and replace it with new ones.
- AutoSock should not be used as direct substitutes for winter tires.
- After use, dry AutoSock, place it in their original packaging, and store it in a dry place. Due to the ease of use of the material, AutoSock can be washed at room temperature to keep the road contact fabric clean but should not be ironed.

## Winter Tires

Tire performance is reduced in low ambient temperatures, resulting in reduced grip and an increased susceptibility to damage from impacts. Performance tires can temporarily harden when cold, causing you to hear rotational noise for the first few kilometers until the tires warm up. To achieve the optimal vehicle performance, please use winter tires in winter. Please choose suitable models of winter tires or studded tires according to the laws of your country.

It is recommended to install winter tires on your vehicle when the ambient temperature is below 7 °C, as the driving performance of summer tires decreases at low temperatures, and so does the comfort. For example, when moving or accelerating out of a corner on dry and slippery roads, chattering noise may occur due to the tires.

Extremely low temperatures below about -15 °C can cause permanent damage to summer tires.

Use the same brand and tread pattern of winter tires on all wheels to ensure safe driving characteristics.

Tire Size	Speed rating
255/50 R20	109T XL
265/45 R21	108T XL

### Caution

- Exceeding the maximum speed rating of the tire will damage the tire. This may also lead to tire blowouts. Never exceed the maximum speed rating of the tires.
- Winter tires with a tread depth of less than 4 mm must be replaced immediately. Such tires are no longer suitable for winter use and can no longer provide adequate grip. As a result, you may lose control of your vehicle and cause an accident.

## Tire Repair

### Warning

- If you continue to drive in the event of a tire puncture, a flat tire accident is likely to occur, endangering personal safety.
- Avoid skin or eye contact with tire sealant. Please keep tire sealant out of reach of children. When tire sealant is used, fire ignition, open flames and smoking are prohibited.
- If tire sealant is exposed to your skin or enters your eyes, immediately clean your affected body parts completely with a large amount of water. Change contaminated clothing immediately. If you have an allergic reaction, seek medical attention immediately. If you swallow tire sealant, immediately rinse your mouth out thoroughly and drink a lot of water. Do not induce vomiting.

### Caution

- Please check the expiry date marked on the container before using tire sealant.
- If the width of the puncture on a 20-inch tire is below 6 mm, we recommend that you remove the foreign object and repair the tire with tire sealant. If the width of the puncture is over 6 mm or the tire is severely damaged, please safely stop the vehicle and contact NIO immediately for tire replacement.
- If the tire is repaired without removing the foreign object, it will cause an abnormal noise while driving and may result in a tire leak over long distances.

### Note

- The 21-inch tires are self-sealing tires. When the width of a tire puncture is less than five millimeters and the tire pressure shown on the center display is normal, the vehicle can still be driven under 120 km/h. Once punctured, the self-sealing tire cannot be used for a long period of time. If the tire is severely punctured or damaged, please contact NIO immediately for tire inspection or replacement.
- Please adjust the puncture to the top of the tire when repairing it.
- Tire sealant can only be used to repair the tread and shoulder areas.

Park the vehicle safely on a flat and solid road as far away from traffic as possible and shift into PARK. After putting on the reflective vest, setting up the warning

triangle, and turning on the hazard warning lights, you can start repairing the 20-inch tires with the tire sealant and tire inflator in the emergency kit:

1. Park the vehicle on a safe road and set up the warning triangle in an appropriate location.
2. Open the emergency kit in the trunk and take out the tire sealant canister and the tire inflator.



3. Remove the maximum speed label from the tire sealant canister and place it on the steering wheel to remind yourself not to drive over 80 km/h.
4. Connect the tire sealant canister to the wheels, remove the tire valve cap, and connect the tire sealant hose to the valve (1). Take out the inflation hose on the side of the tire inflator and connect it to the tire sealant canister inlet valve (2). Turn the tire sealant canister upside down and slide it into the slot on the tire inflator (3).

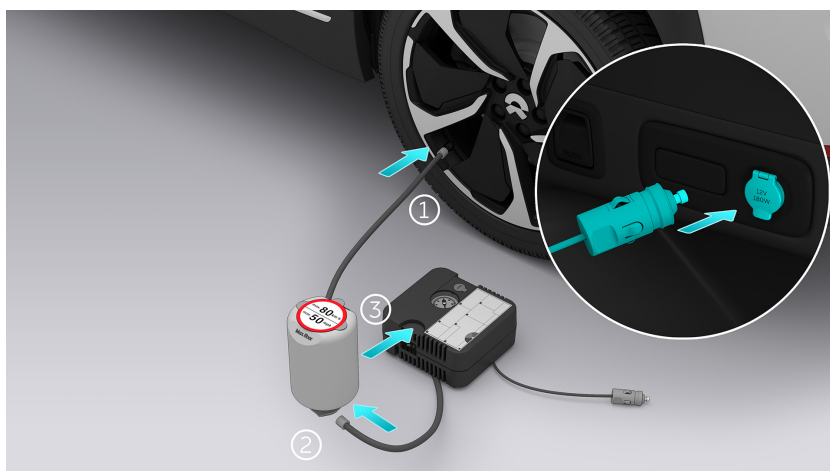

5. Connect the power plug of the tire inflator to the 12V power socket in the vehicle.

6. Make sure the vehicle is powered on, turn on the tire inflator and start to inject tire sealant into the tire. Observe the pressure gauge, and turn it off when the pointer reaches  $\geq 2.2$  bar (which will take around five to 10 minutes). Turn off the tire inflator and disconnect the power plug from the 12V power socket.

**Note**

When the tire inflator begins operating, the pressure gauge will initially display a high pressure up to six bar, after which the pressure will drop to a normal range.

7. Remove the inflation hose of the tire inflator from the tire valve and stow it in the emergency kit.
8. Drive the vehicle 3 to 10 km (or about five to ten minutes) at under 80 km/h to evenly spread the tire sealant and plug the puncture.

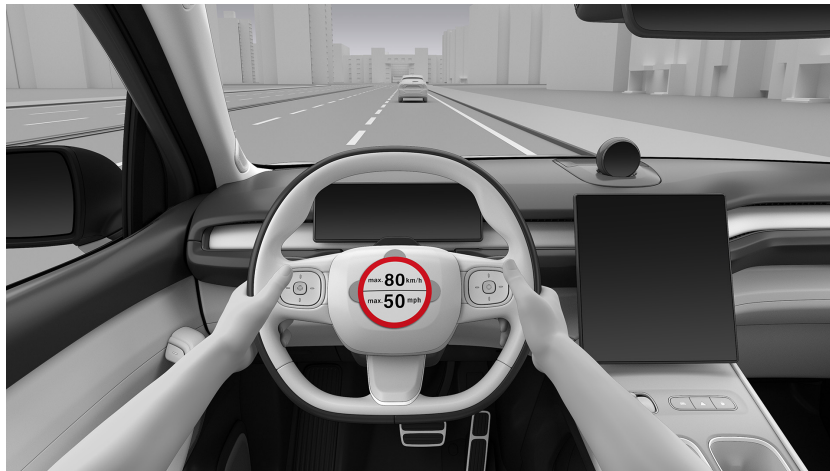

9. Park the vehicle on a safe road, set up the warning triangle, and check the tire pressure readings on the center display. Continue driving if the tire pressure is  $\geq 2.2$  bar. Inflate the tire to  $\geq 2.2$  bar if the tire is under-inflated and drive the vehicle at a speed no higher than 80 km/h for 3 to 10 km (or around 5 to ten

minutes). Check the tire pressure again. If the tire pressure is still below 2.2 bar which means the tire is severely damaged or the tire sealant cannot seal the tire, park the vehicle in a safe place and contact NIO immediately.

### Caution

- If the tire pressure gauge is unable to reach the green zone within 12 minutes after repair then the tire is severely damaged. Please stop driving the vehicle and contact NIO.
- Tire sealant is only a temporary solution for emergencies and the vehicle can be driven for up to 200 kilometers at most. Please take the vehicle to the nearest repair shop for tire repair or replacement.



## Tire Replacement

If a tire cannot be repaired with tire sealant due to a severe leak, park the vehicle safely on a flat and solid road as far away from traffic as possible and shift into PARK. Put on the reflective vest, set up the warning triangle, turn on the hazard warning lights, and contact NIO for tire replacement.

### Warning

- When replacing tires, you need to choose new tires with the same specifications as the original tires. Tires with inconsistent specifications may affect the maneuverability of your vehicle and cause your vehicle to lose control.
- When jacking your vehicle for tire replacement, please ensure that nobody enters the area under the jacked vehicle. Otherwise, injury may occur as a result.
- If anyone is in your vehicle, please do not jack your vehicle.
- Lift your vehicle only at the prescribed underbody jacking point.
- When jacking your vehicle, please do not place any objects on or under the jack.
- Never jack your vehicle on an uphill, downhill or sloping road.
- The jack is only suitable for jacking your vehicle for tire replacement.

Follow the instructions to replace the tire:

1. Prepare a jack and a spare tire of the correct specifications.
2. Place a stopper in front of the tire diagonal to the flat tire to prevent the vehicle from slipping.
3. Enter Settings from the bottom of the center display, and tap **Driving > Jack Mode** to maintain the suspension at the current height and avoid height changes during tire replacement.
4. Remove the lug cap with the removal tool in the emergency kit, and then turn the lug wrench counterclockwise to loosen the lug nuts.

**Caution**

Tire rims have a special protective coating. When removing or installing lug nuts, tires or rims, take reasonable precautions to protect the rim's surface from accidental scratches caused by hard or sharp objects.

5. Position the jack at the correct jacking point.

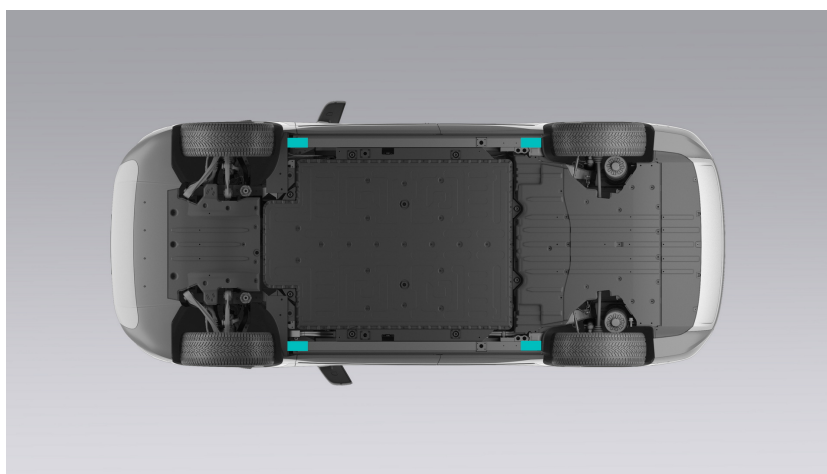
**Warning**

Make sure the jack is positioned correctly under the jack point. Failure to do so may damage the vehicle, or the vehicle may slip off the jack and cause injury.

6. Jack up the vehicle until the flat tire is sufficiently above the ground. When lifting the vehicle, ensure the jack is properly positioned.

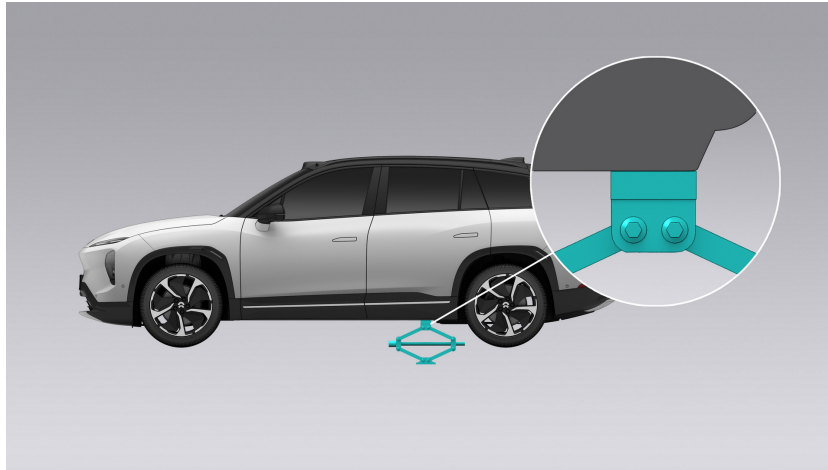

7. Remove the lug nuts and change the flat tire. When mounting the new tire, ensure the lug nuts are aligned with the mounting holes and the metal surface of the rim is in proper contact with the mounting surface.
8. After installing the lug nuts, use the jack to lower the vehicle to the ground and exit the Jack Mode on the center display. Tighten all the lug nuts clockwise with the lug wrench. Then, use a torque wrench to tighten the lug nuts to the specified torque.
9. Check the tire pressure after replacement. If necessary, inflate the tires to the rated range, and then replace the tire valve cap.
10. Properly stow all the tools, the jack, and the flat tire.

## Placing a Warning Triangle

In case of an emergency, please slowly and steadily drive the vehicle to a safe area, press the brake pedal to stop the vehicle, and shift into PARK. Then, you should turn on the hazard warning lights by pressing the button on the center console to warn other vehicles approaching from behind.

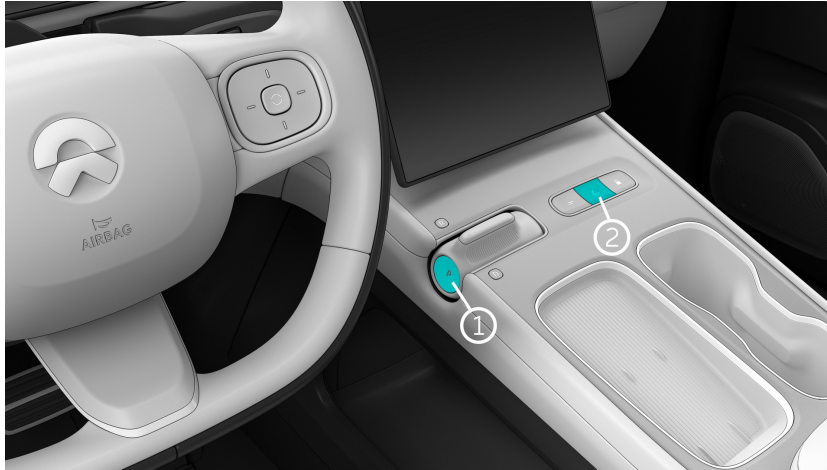

1. PARK button
2. Hazard warning light button

Open the cargo cover inside the trunk and take out the warning triangle and reflective vest from the emergency kit. You should put on the reflective vest first, and then place the warning triangle at around 50 meters to 100 meters behind the vehicle (at least 150 meters behind the vehicle on the highway; add an additional 100 meters at night; 200 meters behind the vehicle in case of rain or fog).

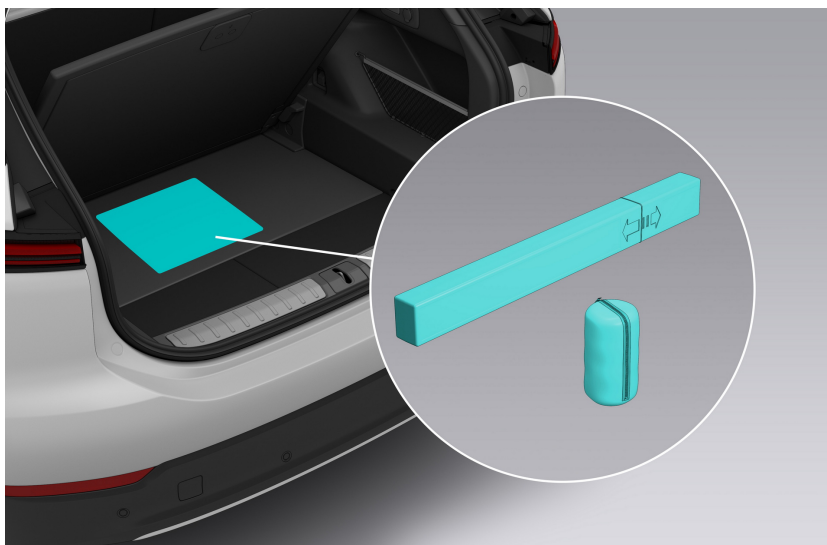

Instructions for setting up the warning triangle:

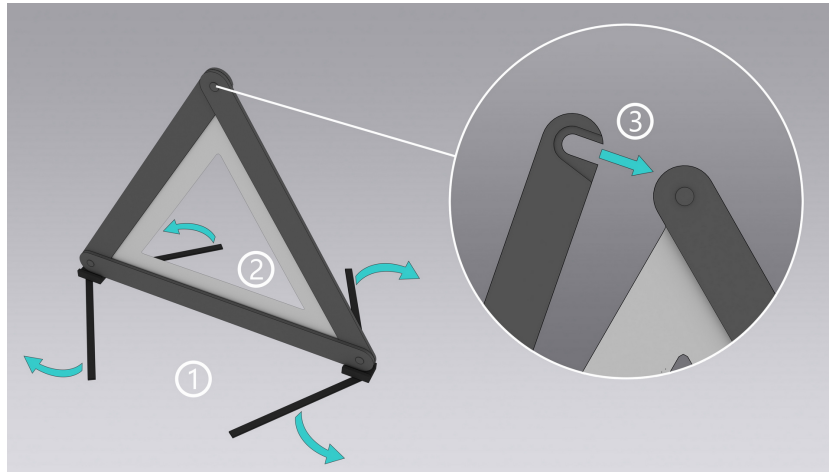

1. Deploy the bracket under the triangle.
2. Unfold the two sides of the triangle.
3. Fasten the buckle on top of the triangle.

## Contacting NIO

In case of accidents such as collisions, floods, and battery fires, contact NIO immediately after setting up the warning triangle and wait for the rescue team.

### Warning

In the event of a battery fire risk, the vehicle will automatically cut off power and the instrument cluster and center display will display a warning message. Make sure the surrounding area is safe and promptly leave the vehicle to call for help.

- When your vehicle is connected to the Internet, you can press the SOS button on the roof console (press and hold once or press twice) to call for rescue. You can cancel the call within eight seconds. The backlight of the SOS button indicates the status of the emergency call: solid green indicates the emergency call function is normal; flashing green indicates an emergency call is in progress; solid red indicates the emergency call function failed and you must contact NIO immediately.



### Note

When the vehicle is connected to the Internet, it will automatically make an emergency call if an accident occurs and the airbag inflates.

### ***The 112-Based E-Call In-Vehicle System***

#### ***Overview***

The 112-based eCall in-vehicle system is mandatory for new vehicle models in all EU countries. In the event of a severe accident, the eCall system can connect you to an appropriate PASP (Public Safety Answering Point) via an audio link

automatically if the vehicle safety system is triggered, or manually if you press the SOS button on the roof console.

The 112-based eCall in-vehicle system is activated by default. It is activated automatically when the activation level for seatbelt tensioner or airbags is reached in the event of a severe accident. The 112-based eCall in-vehicle system can also be activated manually, if needed. To activate the eCall manually, press the SOS button on the roof console for over 250 milliseconds and release the button within 10 seconds. The manual trigger is designed in such a way as to avoid mis-operation. To terminate the calling, press and release the SOS button again within five seconds after it is pressed the first time.

In the event of a critical system malfunction, the 112-based eCall in-vehicle system may be impaired. The backlight of the SOS button indicates the status of the emergency call. Solid green indicates the eCall system functions normally; flashing green indicates an emergency call is in progress; flashing red indicates the eCall system has a minor fault but can still be activated; solid red indicates the eCall system has a major fault and cannot be activated. In this case, you can find the fault notification on the center display, and contact NIO if needed.

### ***Data processing***

The processing of personal data through the 112-based eCall in-vehicle system is in line with the personal data protection rules stipulated in Directives 95/46/EC (1) and 2002/58/EC (2) of the European Parliament and of the Council, and in particular, is based on the necessity to protect the vital interests of the individuals in accordance with Article 7(d) of Directive 95/46/EC (3). The processing of such data is strictly limited to the purpose of handling the emergency call made to the single European emergency number 112 in emergency situations within the meaning of Article 5(2) of Regulation (EU) 2015/758.

### ***Types of data and its recipients***

The 112-based E-Call in-vehicle system may collect and process only the following data:

- Vehicle Identification Number
- Vehicle type (passenger vehicle)
- Vehicle propulsion storage type (gasoline/diesel/CNG/LPG/electric/hydrogen)
- Vehicle last three locations and direction of travel. The recent vehicle locations are selected by random so as to ensure that the IVS is not traceable and not subject to any constant tracking.

- Estimated number of occupants onboard
- Log file of E-Call activation of the system and its timestamp

Recipients of data processed by the 112-based eCall in-vehicle system are the relevant public safety answering points of the area where the car is located. The data may be shared with other parties such as police stations, fire stations, hospitals limited for emergency aid purpose.

### ***Arrangements for data processing***

The 112-based eCall in-vehicle system is designed in such a way as to ensure that:

- Data stored in the system is not available outside the system before an eCall is triggered.
- The system is not traceable and not subject to any constant tracking in its normal operation status.
- Data stored in the system is automatically and continuously removed.
- The vehicle location data is constantly overwritten in the internal memory of the system so as to keep the last three up-to-date locations of the vehicle necessary for the normal functioning of the system.
- The log of activity data in the system is kept for no longer than necessary for attaining the purpose of handling the emergency call and in any case no longer than 13 hours after an emergency call is triggered.

With regard to the arrangements for exercising data subjects' rights as well as the contact service responsible for handling access requests, please kindly contact NIO for support. For contact details, please refer to our Connected Vehicle Privacy Notice or contact details in this manual. NIO GmbH

Data Protection

Montgelastrasse 14

81679 Munich

Germany

privacy.eu@nio.io

00 8000 999 6699 (EU) / 800 24 789 (Norway)



***TPS eCall***

TPS eCall is a third party supported eCall service regard to 112-based eCall in EU. ARC Europe SA will be acting as the TPS agency for NIO TPS eCall, operating the NIO TPS eCall with 24-hours, 7-days availability.

***Service process***

The TPS eCall agent will deliver users with services in the corresponding language according to the language set in the user's vehicle. The TPS eCall agent evaluates if it is a fake or real emergency before addressing the relevant PSAPs, then it cancels the mis-call to help avoid legal risk of mis-connecting to PSAPs. When the incidents occur, the TPS agent can help the user redirect RSA (Road Side Assist service) or advise the user to contact insurance companies providing RSA; if the incident is evaluated to be a crash or an emergency, the TPS agent transfers the MSD to the local Public Safety Answering Point (PSAP) and track the rescue progress in time. During the rescue process, TPS agents can act as a language translation function between the user and the local rescue staff to avoid language barriers in emergency situations.

***Setting***

TPS eCall can be set by the main user in Settings > General in the setting page of the vehicle ICS to replace the statutory eCall. The default option will be TPS eCall. Once the user makes a choice, the choice will be recorded in the user profile.

***Ending***

NIO TPS eCall can only be ended by the TPS agent. Please inform the agent if the call is connected by mistake, and the agent will end the call for you.

***Data collection and handling for TPS eCall******Data processing***

The necessary vehicle data will be collected from the vehicle and sent to NIO TSP, then forwarded to the TPS provider to handle the emergency when TPS eCall is activated by the user's active triggering, collision triggering, and EDA triggering.

Uploaded TPS eCall data will be stored for 6 months to allow NIO to perform accident responding and handling.

***Types of data and its recipients***

After contacting the driver and passengers, the TPS provider will pass the necessary data to the local PSAP in the local language for rescue purposes.

The TPS provider may collect and process only the following data, then send it to the local PSAP when it is needed:

- Driving service information
  - Crash type (front, side, rear, etc.) and delta Velocity ( $V_x$  and  $V_y$ ). (*Note: Delta Velocity is the collection of change of velocity every 10 ms at the X-axis and Y-axis during 250 ms after the crash incident.*)
  - Current vehicle location and direction
  - Vehicle speed
  - Vehicle propulsion storage type
  - Airbag triggered (How many airbags are triggered after the crash)
  - Language set up on the center display
  - Number of passengers
- Contact information
  - User's name (Optional, if the user is registered)
  - User's email address (Optional, if the user is registered)
  - User's mobile number (Optional, if the user is registered)
- Vehicle basic information
  - Make/Model/Color/Model year
  - VIN number

## Jump Starting

When the vehicle cannot start because the 12V battery level is low, you can jump start the vehicle by connecting the jumper cable to the 12V battery of another vehicle.

### Caution

- When jump starting a vehicle, make sure the two vehicles are not in contact with each other. Otherwise, the current generated when the positive terminals of the 12V batteries on the two vehicles are connected will damage the vehicle.
- Connect the positive terminals first, and then the negative terminals.

To avoid short circuits or other damage, we recommend you observe the following procedure when you jump start the vehicle:

1. Put the vehicles in PARK, cut off the power supply of the 12V battery, make sure the jumper cable is correctly connected to the vehicle electrical system, and open the trunk cover of Vehicle A with lower battery level to find the 12V battery.

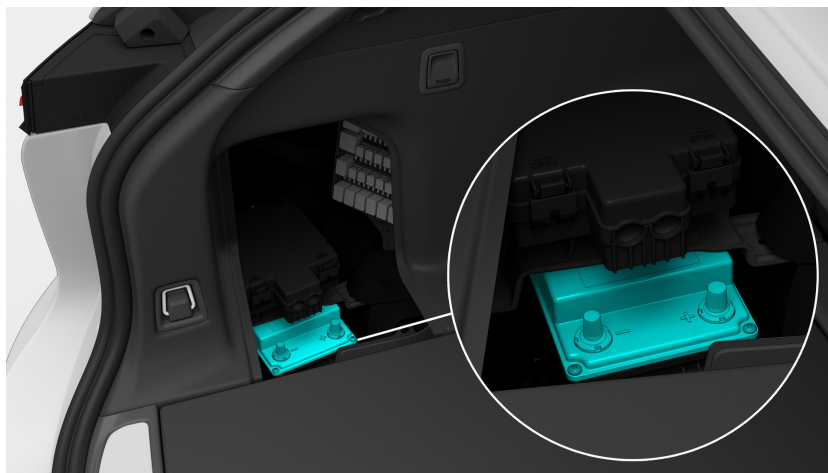

2. Connect one end of the red cable to the positive (+) terminal on the 12V battery on Vehicle A.

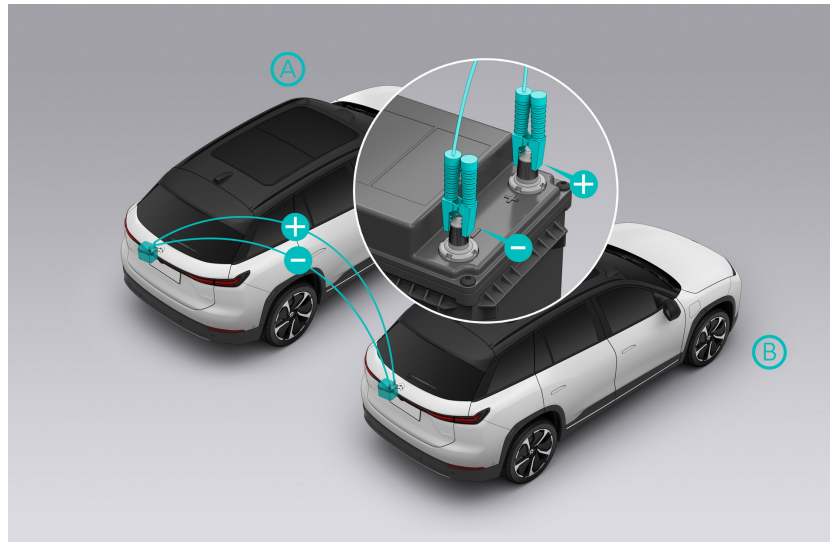

3. Connect the other end of the red cable to the positive (+) terminal of the 12V battery on Vehicle B.
4. Connect one end of the black cable to the negative (-) terminal on the 12V battery of Vehicle B.
5. Connect the other end of the black cable to a proper earthing point of the 12V battery on Vehicle A.
6. Start Vehicle B and let it run for a few minutes. Then, start Vehicle A to check whether it can start up normally.
7. After Vehicle A starts up normally, power off Vehicle B, remove the jumper cables in the opposite order they were connected, and stow all equipment.

## Emergency Unlocking from the Outside

When the vehicle cannot be unlocked by conventional methods (such as a smart key fob, keyless entry, NIO app, or NFC), you can use the emergency key to unlock the driver-side door.

### Caution

Do not leave the emergency key in your vehicle. Please keep it safe in case of emergency.

To use the emergency key:

1. Push the front end of the exterior handle on the driver door.



2. Pull the door handle and insert the emergency key into the lock. Rotate the key counterclockwise to unlock the driver door.



3. To lock the driver door, rotate the key counterclockwise first for unlocking and then turn it clockwise.

### **Caution**

To lock the vehicle with the key fob after it has been unlocked with the emergency key, reset the lock cylinder by unlocking and then locking the driver's door to keep the vehicle safe.

## Emergency Unlocking from the Inside

When the whole vehicle is locked, if the door needs to be opened in an emergency (for example, when the electronic switch on the door handle fails or the vehicle falls into the water), pull the mechanical switch on the interior door handle once to open the corresponding door.

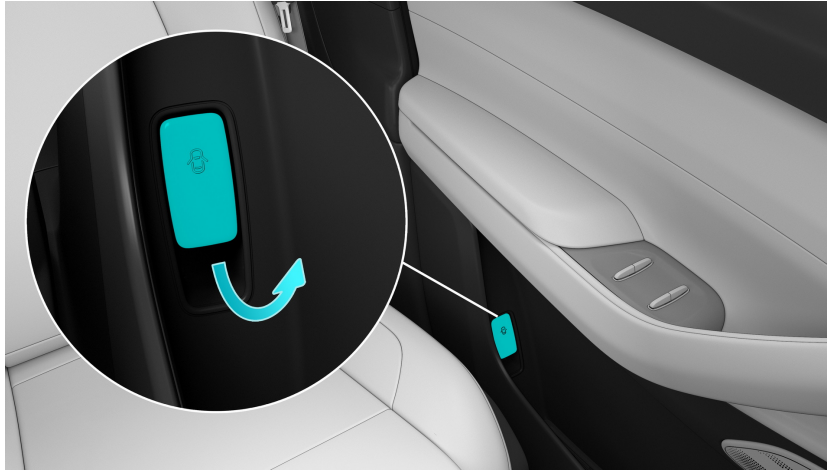

### Caution

- If the 12V battery is drained, you can only unlock the driver door using the emergency key. Other doors can be unlocked and opened from the inside by pulling the mechanical switch on the corresponding interior door handle.
- When Child Lock is on, the rear doors cannot be opened from the inside and can only be opened from the outside when the vehicle is unlocked.

## Emergency Tailgate Opening

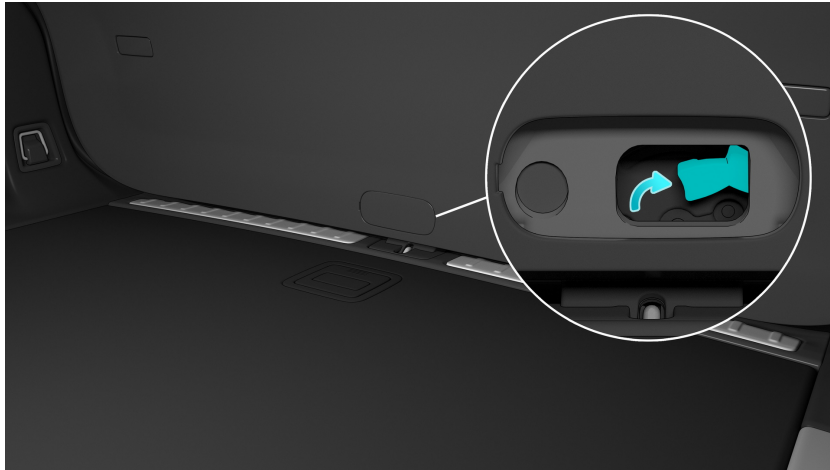

To open the tailgate, lift the oval block above the lock buckle from the inside of the trunk, and then toggle the button in the hole with your finger.



## First Aid Kit

If your vehicle is equipped with a first aid kit, it is located in the trunk side net. The first aid kit contains the necessary treatment items for emergency situations. Please refer to the built-in instructions of the first aid kit for specific instructions.

The first aid kit is **valid for 5 years** . Please contact NIO to purchase a new one after expiration.

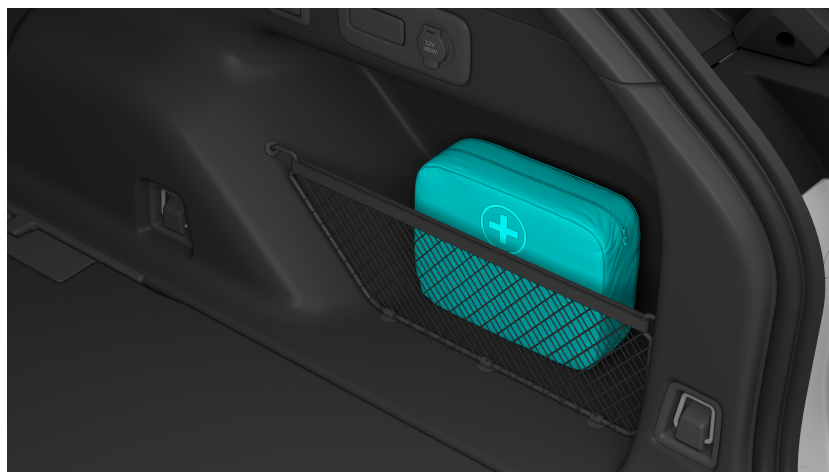

## Protective Equipment for Rescue Operations

The powertrain system is powered by the high voltage battery. Severe collisions and impacts may cause electrical leakage or electrolyte leakage. Therefore, rescue operations should be carried out by professionals who must wear personal protective equipment.

### Warning

Remove all metal objects (such necklaces and watches) before carrying out any operation. Failure to do so may increase the risk of electric shock.

### ***Electrical Protection***

Wear the following protective equipment to avoid high voltage electric shocks:

- Rubber insulating gloves (over 500V insulation resistance)
- Goggles
- Rubber insulating boots
- Insulated tools

### ***Chemical Protection***

In case of electrolyte leakage, wear the following protective equipment to prevent skin and facial injuries:

- Protective face shield
- Chemical-resistant gloves

## Cutting Off the High Voltage Circuit

To cut off the high voltage circuit, disconnect the emergency high voltage cutoff plug (located in the left area under the hood), and then disconnect the cable connected to the negative terminal of the 12V battery (located in the left area of the trunk).

To cut off the high voltage circuit:

1. Pull the hood handle cover in the cabin to unlatch the hood.



2. Toggle the hood latch.

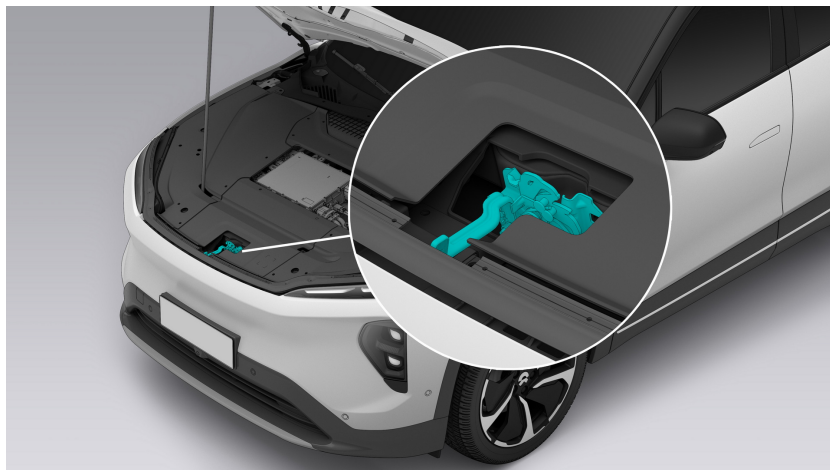

3. Lift the hood, and support it with the prop rod.

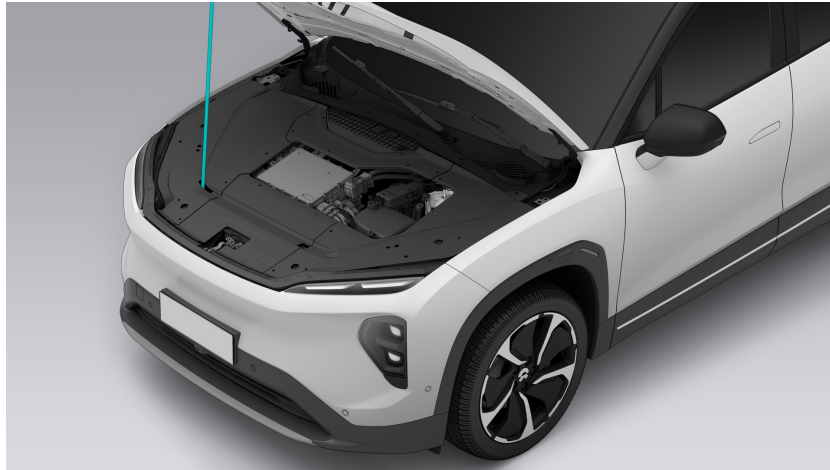

4. Disconnect the emergency high voltage cutoff plug to cut off the high voltage circuit. Remove the plug and stow it appropriately.

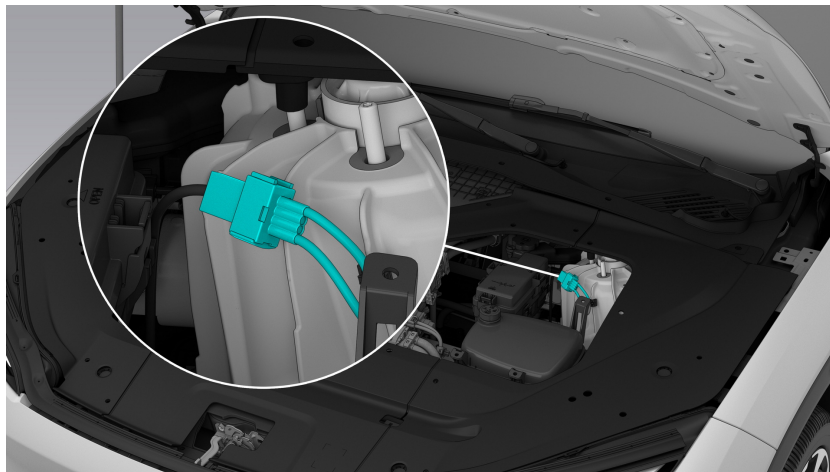

5. Disconnect the cable connected to the negative terminal of the 12V battery. Wrap the cable with a protective layer to avoid conduction due to accidental contact.

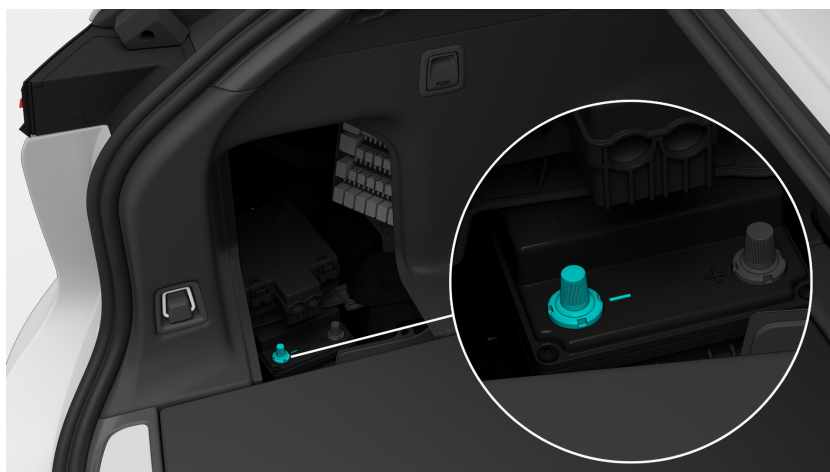

## Towing the Vehicle after an Accident

### Caution

Do not tow your vehicle when the tires are touching the ground and do not tow the vehicle directly with tow chains.

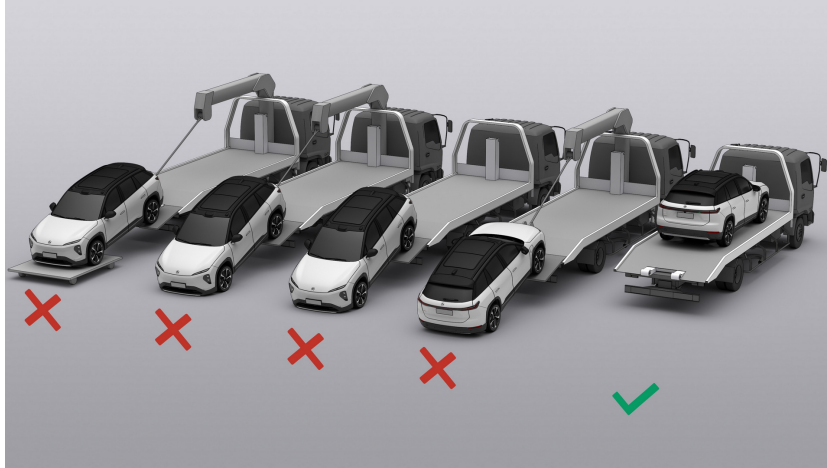

When necessary, transport the vehicle with a flatbed truck.

1. Remove the tow bar from the emergency kit in the trunk.

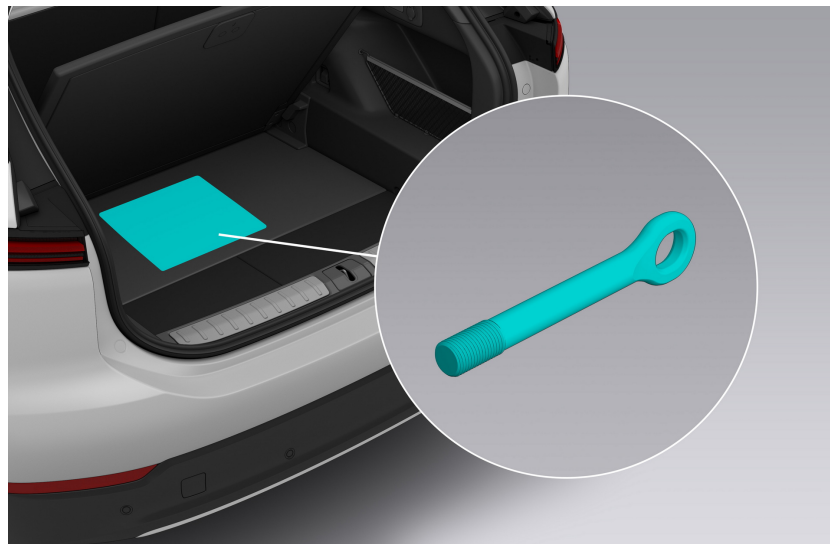

2. Release the tow bar cover by pressing firmly on the lower end of the cover (1). Fully insert the tow bar into the opening, and rotate it until securely fastened (2). The tow bar at the rear is installed in the same way as the front.

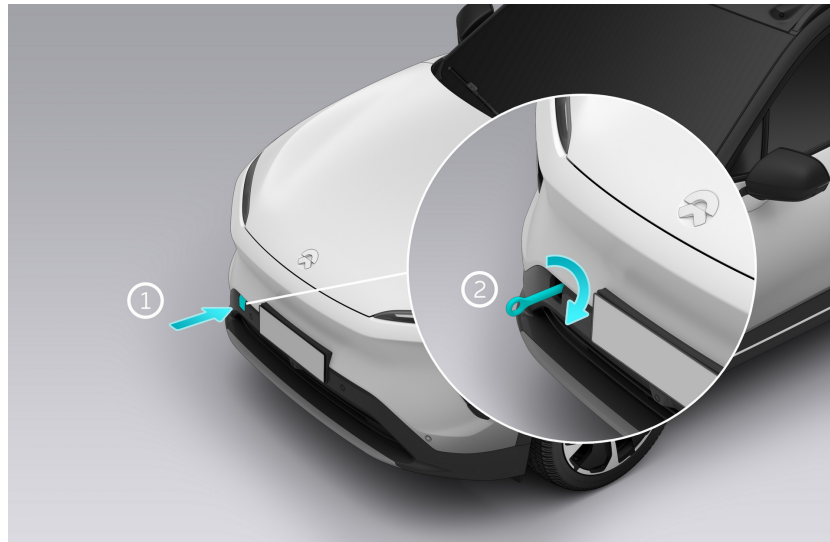

3. Keep the vehicle in PARK, press the brake pedal, Enter Settings from the bottom of the center display, and tap **Driving > Tow/Wash Mode**. The vehicle will release the parking brake and become towable. (Please use the wheel stopper accordingly to prevent sliding.)
4. Before towing, power off the vehicle and turn on the hazard warning lights to ensure that the whole vehicle is locked and no occupant is in the vehicle.
5. Attach the tow chain to the tow bar and slowly tow the vehicle to the flatbed truck.
6. After pulling the vehicle onto the flatbed truck, use the wheel stopper and straps to secure the tires onto the truck.
7. Before transporting the vehicle, exit Tow/Wash Mode on the center display and tap **Driving > Jack Mode** to maintain the suspension at the current ride height and avoid height changes during transportation.

### Caution

- The vehicle can only be towed from the site when there are no safety risks in doing so. If the high voltage battery is deformed, leaking or emitting smoke, address the risk posed by the high voltage battery first.
- Try restarting the 12V battery if Tow/Wash Mode cannot be turned on normally. If the park brake cannot be released, use a tow dolly or a trailer to transport the vehicle a short distance.
- Do not slam on the brake pedal or accelerator pedal when exiting Tow/Wash Mode on the center display.

## Rescuing the Vehicle in Water

### Caution

When driving, do not submerge the vehicle in deep water for a long period of time. Otherwise, the vehicle's high voltage components may be damaged.

If the vehicle body and chassis are not damaged, there will not be any additional risks of electric shock. However, the rescue of a submerged vehicle should be carried out by professionals who must wear personal protective equipment. During rescue operations, first pull the vehicle out of the water and then cut off the high voltage circuit.

## Rescuing the Vehicle on Fire

### Warning

- In the case of a vehicle fire, do not directly touch any part of the vehicle. All rescue operations should be performed by professionals who must wear appropriate personal protective equipment.
- The gas stored in the side curtain airbag cylinder and the high pressure air suspension tank may expand and explode under high temperatures. Please act with caution to avoid injury.

If the vehicle fire doesn't involve the high voltage battery, you can use the fire extinguisher to put out the fire.

If the vehicle fire is caused by the high voltage battery or the high voltage battery is overheated, deformed, cracked, or damaged in the fire, use a large amount of water or foam extinguishing agent mixed with water (F-500 EA is recommended) to cool down the high voltage battery. After the battery is completely cooled down (which may take up to 24 hours), monitor it for one more hour to ensure the battery does not heat up again. Then, drive the vehicle to an open and flat area and set up a 15-meter safety zone to keep people away from the vehicle.

### Warning

Be aware that a high voltage battery may re-ignite even after it is cooled down. Particular attention should be paid when transporting the battery.



## Rescuing the Vehicle with Battery Leakage

### Warning

If leakage from a high voltage battery is caused due to an impact, the rescue should be performed by professionals who must wear protective face shields and chemical-resistant gloves. Never make direct contact with the fluids.

When the high voltage battery leaks, it may generate heat or even cause a fire. Please cool down the high voltage battery first and then clean up the fluids.

- If the leak is not severe, use a liquid absorbing pad to clean up the fluids and then place the used pad in a closed container or use a professional incineration process to dispose of the fluids.
- If the leak is severe, dispose of the fluids following the disposal guidelines for hazardous chemical waste. Pour calcium gluconate solution over the leaked fluids and use gas collection and control devices to dispose of the leaked gases.

### Caution

If any fluids accidentally get on the skin, remove the contaminated clothes, and rinse the skin with soap under running water for 15 minutes until all chemical residues are removed. Seek medical attention immediately if the irritation or discomfort doesn't improve.

## Vehicle Cutting

### Warning

When professional rescuers perform cutting operations, they must use appropriate tools such as a hydraulic cutter and wear appropriate personal protective equipment to avoid serious injury.

The vehicle pillars use aluminum castings to better protect the occupants in case of an impact. Please use proper tools to cut the pillars during a rescue. Do not cut any high temperature or high voltage areas on the vehicle, such as airbag components and high voltage components, as indicated by the red areas below.

